



GCSW36V

Pad Mount Swing Operator, Commercial 36V

Installation, Operation, & Maintenance Manual



Contents

Safety

Coin Cell Battery Safety Warning	1
Safety Symbols and Signal Words	2
SAFETY INSTRUCTIONS	2
UL325 Gate Operator Classifications	4
Entrapment Protection Devices	6-7
Safety Installation Information	8
Gate Construction Information	9

Introduction

What's Included:	10
Operator Specifications	11

Installation

Site Preparation	12
Installing the Operator	14-17
Control Box	18
Manual Release System	19
Install the Warning Signs	19

Wiring

Wiring the Operator	20
Line Voltage Wiring	21
Wiring Diagram	22-23
Earth Ground Rod (Not Provided)	24
Install Entrapment Protection	25
Entrapment Protection Devices	25
Wiring Entrapment Protection Devices	26
Retro-Reflective Photoeye Kit (Included)	27
Installation	28
Alignment	28
Test	28
Troubleshooting	28
Secure the aluminum channel and edge material	29
Installation of the fixed edge	29

Operator Setup Procedures

Control Board Programming	30
Control Operating Modes	30
Menu Item #2 - Set Gate Direction	31
Menu Item #3 - Open Limit	32
Menu Item #4 - Close Limit	32
Menu Item #5 - Reversing Force Gate #1	32
Menu Item #6 - Timer to Close	32
Optional Transmitter Programming	33
Menu Item #7 - Learn New Transmitter	33
Menu Item #8 - Remove a Single Transmitter	34
Menu Item #9 - Remove All Transmitters	35
Menu Item #10 - Set Primary & Secondary Gates	35
Menu Item #11 - Biparting Delay	37
Menu Item #12 - Opening & Closing Speed	37
Menu Item #13 - Slow Down Speed	37
Menu Item #14 - Slow Down Space	38
Menu Item #15 - Deceleration	38
Menu Item #16 - Acceleration	38

Additional Menu Items	39-42
Operator Alarm	43
Reset Button	43
Remote Control	43

Solar Operation	44-46
-----------------	-------

Troubleshooting	48-54
-----------------	-------

Service Parts	55
---------------	----

Accessories	56-57
-------------	-------

Maintenance	58
-------------	----

Warranty

NOTICE: This device complies with Part 15 of the FCC rules and Industry Canada's license-exempt RSSs. Operation is subject to the following two conditions: (1) this device may not cause harmful interference, and (2) this device must accept any interference received, including interference that may cause undesired operation.

Any changes or modifications not expressly approved by the party responsible for compliance could void the user's authority to operate the equipment.

This device has been tested and found to comply with the limits for a Class B digital device, pursuant to part 15 of the FCC rules and Industry Canada ICES standard. These limits are designed to provide reasonable protection against harmful interference in a residential installation. This equipment generates, uses and can radiate radio frequency energy and, if not installed and used in accordance with the instructions, may cause harmful interference to radio communications. However, there is no guarantee that interference will not occur in a particular installation. If this equipment does cause harmful interference to radio or television reception, which can be determined by turning the equipment off and on, the user is encouraged to try to correct the interference by one or more of the following measures:

- Reorient or relocate the receiving antenna.
- Increase the separation between the equipment and receiver.
- Connect the equipment into an outlet on a circuit different from that to which the receiver is connected.
- Consult the dealer or an experienced radio/TV technician for help.

COIN CELL BATTERY SAFETY WARNING

WARNING

- **INGESTION HAZARD:** this product contains a button cell or coin battery.
 - DEATH or serious injury can occur if ingested.
 - A swallowed button cell or coin battery can cause Internal Chemical Burns in as little as 2 hours.
 - KEEP new and used batteries OUT OF REACH OF CHILDREN
 - Seek immediate medical attention if a battery is suspected to be swallowed or inserted inside any part of the body.
-
- Remove and immediately recycle or dispose of used batteries according to local regulations and keep away from children. Do NOT dispose of batteries in household trash or incinerate.
 - Even used batteries may cause severe injury or death.
 - Call a local poison control center for treatment information.
 - Replace only with Type CR2032 3V batteries.
 - Non-rechargeable batteries are not to be recharged.
 - Do not force discharge, recharge, disassemble, heat above (manufacturer's specified temperature rating) or incinerate. Doing so may result in injury due to venting, leakage or explosion resulting in chemical burns.
 - Ensure the batteries are installed correctly according to polarity (+ and -).
 - Do not mix old and new batteries, different brands or types of batteries, such as alkaline, carbon-zinc, or rechargeable batteries.
 - Remove and immediately recycle or dispose of batteries from equipment not used for an extended period of time according to local regulations.
 - Always completely secure the battery compartment. If the battery compartment does not close securely, stop using the product, remove the batteries, and keep them away from children.

AVERTISSEMENT

- DANGER D'INGESTION : Ce produit contient une pile bouton ou une pile bouton.
 - La MORT ou des blessures graves peuvent survenir en cas d'ingestion.
 - Une pile bouton ou une pile bouton avalée peut provoquer des dommages chimiques internes brûle en seulement 2 heures.
 - GARDER les piles neuves et usagées HORS DE LA PORTÉE DES ENFANTS
 - Consultez immédiatement un médecin si vous soupçonnez qu'une batterie est avalé ou inséré dans n'importe quelle partie du corps.
-
- Retirez et recyclez ou jetez immédiatement les piles usagées conformément aux réglementations locales et gardez-les hors de portée des enfants. Ne jetez PAS les piles avec les ordures ménagères ou ne les incinerez pas.
 - Même les piles usagées peuvent provoquer des blessures graves, voire la mort.
 - Appelez un centre antipoison local pour obtenir des informations sur le traitement.
 - Remplacez uniquement par des piles de type CR2032 3 V.
 - Les piles non rechargeables ne doivent pas être rechargées.
 - Ne forcez pas la décharge, la recharge, le démontage, la chaleur au-dessus de la température nominale spécifiée par le fabricant et l'incinération. Cela pourrait entraîner des blessures dues à une ventilation, une fuite ou une explosion entraînant des brûlures chimiques.
 - Assurez-vous que les piles sont installées correctement selon la polarité (+ et -).
 - Ne mélangez pas des piles anciennes et neuves, des marques ou des types de piles différents, tels que des piles alcalines, carbone-zinc ou rechargeables.
 - Retirez et recyclez ou jetez immédiatement les batteries des équipements non utilisés pendant une période prolongée, conformément aux réglementations locales.
 - Sécurisez toujours complètement le compartiment à piles. Si le compartiment des piles ne se ferme pas correctement, arrêtez d'utiliser le produit, retirez les piles et gardez-les hors de portée des enfants.

Safety

WARNING

Gates are large, heavy objects that move with the help of electric motors. Since moving objects and electric motors can cause injuries, your safety and the safety of others depend on you reading the information in this manual. If you have any questions or do not understand the information presented, call your nearest service representative. For the number of your local Genie® Dealer, call 800-OK-GENIE, and for Genie® Factory Technical Advice, call 800-843-4084.

In this Manual, the words Danger, Warning, and Caution are used to stress important safety information.





The word:

 **DANGER** INDICATES A HAZARDOUS SITUATION THAT, IF NOT AVOIDED, WILL RESULT IN DEATH OR SERIOUS INJURY.

 **WARNING** INDICATES A HAZARDOUS SITUATION THAT, IF NOT AVOIDED, COULD RESULT IN DEATH OR SERIOUS INJURY.

 **CAUTION** INDICATES A HAZARDOUS SITUATION THAT, IF NOT AVOIDED, COULD RESULT IN MINOR OR MODERATE INJURY.

 **NOTICE** INDICATES INFORMATION CONSIDERED IMPORTANT, THAT IS NOT RELATED TO INJURY, BUT MAY RESULT IN PROPERTY DAMAGE.

POTENTIAL HAZARD	EFFECT	PREVENTION
<p>MOVING GATE</p> 	<p> WARNING</p> <p>Could result in Serious Injury or Death</p>	<p>Do Not operate unless the gate opening is in sight and free of obstructions. Keep people clear of opening while gate is moving.</p> <p>Do Not allow children to play with the gate opener.</p> <p>Do Not change actuator control to momentary contact unless an external reversing means is installed.</p>
<p>ELECTRICAL SHOCK</p> 	<p> WARNING</p> <p>Could result in Serious Injury or Death</p>	<p>Turn off electrical power before removing actuator cover. When replacing the cover, make sure wires are not pinched or near moving parts.</p> <p>Actuator must be electrically grounded.</p>

SAFETY INSTRUCTIONS

WARNING

To reduce the risk of severe INJURY or DEATH:

- READ AND FOLLOW ALL INSTRUCTIONS.
- NEVER let children operate or play with gate controls. Keep the remote control away from children.
- ALWAYS keep people and objects away from the gate. NO ONE SHOULD CROSS THE PATH OF THE MOVING GATE.
- Test the gate operator monthly. The gate MUST reverse on contact with an object or reverse when an object activates the non-contact sensors. After adjusting the force or the limit of travel, retest the gate operator. Failure to adjust and retest the gate operator properly can increase the risk of INJURY or DEATH.
- Use the emergency release ONLY when the gate is not moving.
- KEEP GATES PROPERLY MAINTAINED. Read the owner's manual. Have a qualified service person make repairs to gate hardware.
- The entrance is for vehicles ONLY. Pedestrians MUST use separate entrance.
- **SAVE THESE INSTRUCTIONS.**

⚠ AVERTISSEMENT

Les barrières sont de grands objets lourds qui se déplacent à l'aide de moteurs électriques. Comme les objets en mouvement et les moteurs électriques peuvent causer des blessures, votre sécurité et celle des autres dépendent de la lecture des informations contenues dans ce manuel. Si vous avez des questions ou si vous ne comprenez pas les informations présentées, appelez le représentant du service après-vente le plus proche. Pour obtenir le numéro de votre revendeur Genie® local, appelez le 800-OK-GENIE, et pour obtenir les conseils techniques de l'usine Genie®, appelez le 800-843-4084.

Dans ce manuel, les mots Danger, Avertissement, et Attention sont utilisés pour souligner des informations de sécurité importantes.

Le mot :

⚠ DANGER

INDIQUE UNE SITUATION DANGEREUSE QUI, SI ELLE N'EST PAS ÉVITÉE, PEUT ENTRAÎNER LA MORT OU DES BLESSURES GRAVES. LA MORT OU DES BLESSURES GRAVES.

⚠ AVERTISSEMENT



INDIQUE UNE SITUATION DANGEREUSE QUI, SI ELLE N'EST PAS ÉVITÉE, PEUT ENTRAÎNER LA MORT OU DES BLESSURES GRAVES. LA MORT OU DES BLESSURES GRAVES.

⚠ ATTENTION

INDIQUE UNE SITUATION DANGEREUSE QUI, SI ELLE N'EST PAS ÉVITÉE, PEUT ENTRAÎNER DES BLESSURES MINEURES OU MODÉRÉES.

AVIS

INDIQUE UNE INFORMATION CONSIDÉRÉE COMME IMPORTANTE, QUI N'EST PAS LIÉE À DES BLESSURES, MAIS QUI PEUT ENTRAÎNER DES DOMMAGES MATÉRIELS.

DANGER POTENTIEL	EFFET	PRÉVENTION
PORTE EN MOUVEMENT 	⚠ AVERTISSEMENT Pourrait entraîner des blessures graves voire la mort	Ne pas faire fonctionner le portail si l'ouverture n'est pas visible et libre de tout obstacle. Tenir les personnes à l'écart de l'ouverture lorsque le portail est en mouvement. Ne pas laisser les enfants jouer avec l'ouvre-portail. Ne pas changer la commande de l'actionneur pour un contact momentané à moins qu'un moyen d'inversion externe ne soit installé.
CHOC ÉLECTRIQUE 	⚠ AVERTISSEMENT Pourrait entraîner des blessures graves voire la mort	Couper l'alimentation électrique avant de retirer le couvercle de l'actionneur. Lors de la remise en place du couvercle, s'assurer que les fils ne sont pas pincés ou à proximité de pièces mobiles. L'actionneur doit être mis à la terre.

CONSIGNES DE SÉCURITÉ

⚠ AVERTISSEMENT

Pour réduire les risques de blessures graves ou de décès:

- LISEZ ET SUIVEZ TOUTES LES INSTRUCTIONS.
- Ne laissez JAMAIS les enfants utiliser ou jouer avec les commandes du portail. Tenir la télécommande hors de portée des enfants.
- Éloignez TOUJOURS les personnes et les objets de la barrière. PERSONNE NE DOIT TRAVERSER LA TRAJECTOIRE DU PORTAIL EN MOUVEMENT.
- Testez l'opérateur du portail tous les mois. Le portail DOIT s'inverser au contact d'un objet ou s'inverser lorsqu'un objet active les capteurs sans contact. Après avoir réglé la force ou la limite de course, testez à nouveau l'opérateur de portail. Le fait de ne pas régler et retester correctement l'opérateur de portail peut augmenter le risque de BLESSURES ou de MORT.
- Utiliser le déverrouillage d'urgence UNIQUEMENT lorsque la barrière n'est pas en mouvement.
- MAINTENIR LES PORTAILS CORRECTEMENT ENTRETENUS. Lisez le manuel du propriétaire. Demandez à un technicien qualifié de réparer la quincaillerie du portail.
- L'entrée est réservée UNIQUEMENT aux véhicules. Les piétons DOIVENT emprunter une autre entrée.
- **CONSERVEZ CES INSTRUCTIONS.**

UL325 Gate Operator Classifications

Class I - Residential Vehicular Gate Operator

A vehicular gate operator (or system) intended for use in garages or parking areas associated with a residence of one to four single families.

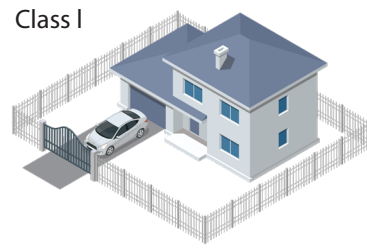

Class II - Commercial/General Access Vehicular Gate Operator

A vehicular gate operator (or system) intended for use in a commercial location or building such as a multi-family housing unit (five or more single family units), hotel, garages, retail stores, or other buildings accessible by or servicing the general public.

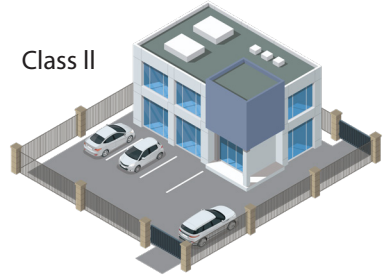

Class III - Industrial/Limited Access Vehicular Gate Operator

A vehicular gate operator (or system) intended for use in an industrial location or building such as a factory or loading dock area or other locations not accessible by, or intended to service, the general public.

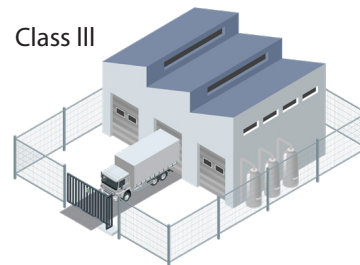

Class IV - Restricted Access Vehicular Gate Operator

A vehicular gate operator (or system) intended for use in a guarded industrial location or building such as an airport security area or other restricted access locations not servicing the general public, in which unauthorized access is prevented via supervision by security personnel.



Entrapment Protection Devices

- Per UL 325 requirements, your gate installation will not go into momentary contact (automatic operation) until the appropriate number of external monitored safety devices are wired into the operator and are in an unobstructed state.
- There are two different types of external monitored safety devices: contact (safety edges) and non-contact (photo eyes). Safety edges used with this operator must be 10k Ohm resistively terminated. Photo eyes used with this gate operator can be either 2-wire pulsed aka "SAF-T-BEAM" (default type) or 4-wire 10k Ohm N/O type (selectable via LCD menu).
- The UL 325 Standard requires that, regarding the connection of monitored entrapment protection devices, "it shall not be possible to make simple modifications in the field by adding, suppressing, or changing either on the operator or external entrapment protection device(s), to bypass, interfere with, or otherwise defeat the monitoring function." (Section 32.1.10).

SWING GATES UL 325 REQUIREMENTS:

- To go into automatic operation, each swing gate operator requires one monitored entrapment device wired in the close direction and must be unobstructed before automatic operation will be enabled. If there are entrapment zones in the open direction of travel, then additional monitored entrapment device(s) must be wired into the open direction. If the number of additional entrapment devices exceeds the number of inputs on the operator logic board, the expansion module from the table on the following page must be used.

SLIDE GATES UL 325 REQUIREMENTS:

- To go into automatic operation, each slide gate operator requires two monitored entrapment devices, one in the close direction and one in the open direction, and both must be unobstructed prior to automatic operation. If there are more than one entrapment zone in the open or close direction of travel, then additional monitored entrapment device(s) must be provided for each additional entrapment zone. If the number of additional entrapment devices exceeds the number of inputs on the operator logic board, the MIM-62 expansion module from the table on the following page must be used.

Safety

- The operator can be used with the following UL Approved entrapment devices in compliance with UL325 requirements. The approved external monitored external entrapment devices must be wired to the operator according to the provided wiring diagrams.
- NOTICE** With AC power applied, safety devices remain powered on continuously. When powered only by battery backup or solar powered installations, safety devices will remain off until activation input is received; then safety devices will power up and monitor entrapment while gate moves.

Device Type		BRAND	Model or Part Number	Genie Part Number	Max Range (FT)	Details
Photo Eyes	Retro-Reflective	Genie	GAKRRPE.S*	GAKRRPE.S*	45	2-Wire Pulsed
		EMX	IRB-RET2	113390.0001.S	60	2-Wire Pulsed or 10K 4-Wire
		Omron	E3K-R10K4-NR-1	113468.0001.S	40	10k 4-Wire
	Thru Beam	Genie	GAKTBPE.S	GAKTBPE.S	49	2-Wire Pulsed
		Cedes	OSE-S-1512	OPAKPEN4GX.S	50	2-Wire Pulsed
		EMX	IRB-MON2	113392.0001.S	115	2-Wire Pulsed or 10K 4-Wire
Edge Sensors (2-Wire)	10K OHM	ASO	Sentir Edge 25.30 TT**	113424.0001.S**		Profile: Standard 25mm W x 30mm H
			Sentir Edge 15-10 TT			Mini 15.5mm W x 9.1mm H
			Sentir Edge 92.20 RT			2" Round - Wrap Around
			Sentir Edge 92.20 AT			2" Square - Wrap Around
	Miller Edge	MG110			.875 in W x .75 in H	
		ME120			1.5 in x 1.75 in H	
		MGR20	113414.0001.S		2" Round - Wrap Around	
		MGS20	113413.0001.S		2" Square - Wrap Around	
		CPT210			7/8" W x 1-1/8" H	
		CPT223 (CPT215)			1-11/16" W x 1-5/8" H	
Edge Wireless Kits	EMX	WEL-200	OPAKMCWE.S		Wireless Edge Adapter	
	Miller Edge	R-Band RB-G-K10				
Multi Input Module	Miller Edge	MIM-62	113410.0001.S		6 Input to 2 Outputs Entrapment Expansion	

Notes:

* Monitored photo eye (Qty 1), included with each swing and slide gate operator

** Monitored edge, 5ft long (Qty 1), included with each slide gate operator.

Safety Installation Information

1. Install the gate operator only when:
 - a. The operator is appropriate for the construction and the usage class of the gate
 - b. All exposed pinch points are eliminated or guarded, and guarding is supplied for exposed rollers.
2. The operator is intended for installation only on gates used for vehicles. Pedestrians must be supplied with a separate access opening. The pedestrian access opening shall be designed to promote pedestrian usage. Locate the gate such that persons will not come in contact with the vehicular gate during the entire path of travel of the vehicular gate.
3. The gate must be installed in a location so that enough clearance is supplied between the gate and adjacent structures when opening and closing to reduce the risk of entrapment. Swinging gates shall not open into public access areas.
4. The gate must be properly installed and work freely in both directions prior to the installation of the gate operator.
5. The gate operator controls must be placed so that the user has full view of the gate area when the gate is moving AND AWAY FROM THE GATE PATH PERIMETER.
6. Permanently mounted access controls intended for users to activate must be located at least 6 feet (1.8 m) away from any moving part of the gate, and where the user is prevented from reaching over, under, around, or through the gate to operate the controls. Outdoor, or easily accessible, controls shall have a security feature to prevent unauthorized use. Exception: Emergency access controls only accessible by authorized personnel (e.g. fire, police) may be placed at any location in the line-of-sight of the gate.
7. The Stop and/or Reset (if provided separately) must be located in the line-of-sight of the gate. Activation of the reset control shall not cause the operator to start.
8. A minimum of two (2) WARNING SIGNS shall be installed in the area of the gate. Each placard is to be visible by persons located on the side of the gate on which the placard is installed.
9. For a gate operator utilizing a non-contact sensor:
 - a. Reference owner's manual regarding placement of non-contact sensor for each type of application.
 - b. Care shall be exercised to reduce the risk of nuisance tripping, such as when a vehicle trips the sensor while the gate is still moving.
 - c. One or more non-contact sensors shall be located where the risk of entrapment or obstruction exists, such as the perimeter reachable by a moving gate or barrier.
10. For a gate operator utilizing a contact sensor such as an edge sensor:
 - a. One or more contact sensors shall be located where the risk of entrapment or obstruction exists.
 - b. A hard-wired contact sensor shall be located and its wiring arranged so the communication between the sensor and the gate operator is not subject to mechanical damage.
 - c. A wireless device such as one that transmits radio frequency (RF) signals to the gate operator for entrapment protection functions shall be located where the transmissions of the signals are not obstructed or impeded by building structures, natural landscaping, or similar obstruction. A wireless device shall function under the intended end-use conditions.
 - d. One or more contact sensors shall be located on the inside and outside leading edge of a swing gate. Additionally, if the bottom edge of a swing gate is greater than 4 inches (10.1 cm) but less than 16 inches (406 mm) above the ground at any point in its arc of travel, one or more contact sensors shall be located on the bottom edge.

Gate Construction Information

Vehicular gates should be installed in accordance with ASTM F2200: Standard Specification for Automated Vehicular Gate Construction. For a copy, contact ASTM directly at 610-832-9585 or www.astm.org.

4. General Requirements

- 4.1 Gates shall be constructed in accordance with the provisions given for the appropriate gate type listed in Sections 5 – 10.
- 4.2 Gates shall be designed, constructed, and installed to not fall over more than 45 degrees from the vertical plane, when a gate is detached from the supporting hardware.
- 4.3 Gates shall have smooth bottom edges, with vertical bottom edged protrusions not exceeding 0.50 in. (12.7 mm) when other than the Exceptions listed in 4.8.
- 4.4 The minimum height for barbed tape shall not be less than 8 ft (2.44 m) above grade.
- 4.5 The minimum height for barbed wire shall not be less than 6 ft (1.83 m) above grade.
- 4.6 An existing gate latch shall be disabled when a manually operated gate is retrofitted with a powered gate operator.
- 4.7 A gate latch shall not be installed on an automatically operated gate.
- 4.8 Protrusions shall not be permitted on any gate.

Exceptions:

- 4.8.1 For all gates, vertical bottom edge protrusions not exceeding 0.50 in. (12.7 mm) which shall be smooth on all surfaces with no sharp edges.
- 4.8.2 For all gates, gate locks and edge sensors shall not be considered protrusions.
- 4.8.3 Protrusions at the leading and trailing vertical gate edges shall not exceed 0.50 in. (12.7 mm), and shall be smooth on all surfaces with no sharp edges.
- 4.8.4 Top pickets and top decorative designs shall not be considered protrusions, provided they are in a vertical plane with respect to the gate. Protrusions extending outside the vertical plane shall be permitted, provided such protrusions are located 7 ft (2.13 m) or more above grade.
- 4.9 Gates shall be designed, constructed, and installed such that their movement shall not be initiated by gravity when an automatic operator is disconnected, in accordance with the following.
- 4.9.2 Vehicular horizontal swing gate. Shall not result in continuous, unimpeded movement in either direction along the arc of its path of travel.
- 4.10 For pedestrian access in the vicinity of an automated vehicular gate, separate pedestrian access shall be provided or available. The pedestrian access shall be in a location such that a pedestrian shall not come in contact with a moving vehicular access gate during the entire path of travel of the vehicular gate. A pedestrian gate shall not be incorporated into an automated vehicular gate panel.

5. Specific Applications

- 5.1 Any non-automated gate that is to be automated shall be upgraded to conform to the provisions of this specification.
- 5.2 This specification shall not apply to gates generally used for pedestrian access and to vehicular gates not to be automated.
- 5.3 When the gate operator requires replacement, the existing gate shall be upgraded to conform to the provisions of this specification.
- 5.4 When the gate of an automated gate system requires replacement, the new gate shall conform to the provisions of this specification.

7. Vehicular Horizontal Swing Gates

- 7.1 The following provisions shall apply to Class I, Class II, and Class III vehicular horizontal swing gates:
 - 7.1.1 Gates shall be designed, constructed, and installed so as not to create an entrapment area between the gate and the supporting structure or other fixed object when the gate moves toward the fully open position, subject to the provisions in 7.1.1.1 and 7.1.1.2.
 - 7.1.1.1 The width of an object (such as a wall, pillar, or column) covered by a swing gate when in the open position shall not exceed 4 in. (102 mm), measured from the centerline of the pivot point of the gate.
Exception: For a gate that is not in compliance with this provision, the defined area shall be subject to the entrapment protection provisions of UL 325.
 - 7.1.1.2 Except for the zone specified in 7.1.1.1, the distance between a fixed object such as a wall, pillar, or column and a swing gate when in the open position shall not be less than 16 in. (406 mm).
Exception: For a gate that is not in compliance with this provision, the defined area shall be subject to the entrapment protection provisions of UL 325.
 - 7.2 Class IV vehicular horizontal swing gates shall be designed, constructed, and installed in accordance with security related parameters specific to the application in question.

THIS PAGE LEFT BLANK

Introduction

What's Included:



Pad Mount Swing Operator



Warning Signs (2)



Keys (2)

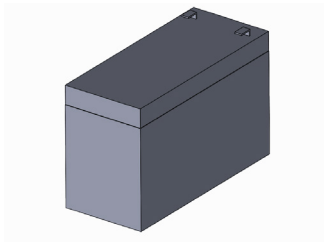

12V 7Ah Battery (2)



5ft Edge Kit (2)



3-Button Transmitter (2)

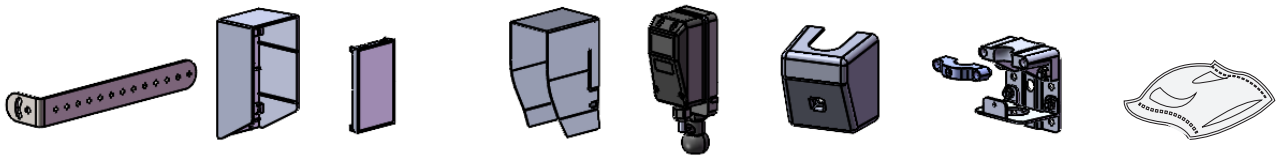

Retro-Reflective Photoeye Kit with Hardware (Qty. 1 of each item shown)

Operator Specifications

Usage Classification	Class I, II, III, & IV
Power Source	115VAC 60Hz, field switchable to 230VAC 60Hz or Optional Solar Powered
Solar Charge Controller	On board charge controller up to 20W 24VDC Optional external charge controller up to 90W 24VDC
Motor Voltage	36V Brushless DC
Accessory Power Maximum	24VDC, 800mA combined on Constant + Switched Acc Power
Battery Backup	(2) 7Ah 12V Included (2) 35Ah 12V Optional
Gate Leaf Weight (maximum)	1500 lbs (680 kg) @ 10 ft (3.0 m)
Gate Leaf Length (maximum)	18 ft (5.5 m) @600 lbs (272 kg)
Opening Time	15-18 sec
Maximum Opening Swing	110°
Duty Cycle Rating	Continuous Duty
Gate Weight @ Gate Length	1500 lbs (680 kg) @ 10 ft (3.0 m) 1200 lbs (544 kg) @ 12 ft (3.6 m) 1000 lbs (453kg) @ 14 ft (4.3 m) 800 lbs (363 kg) @ 16 ft (4.9 m) 600 lbs (272 kg) @ 18 ft (5.5 m)
Operating Temperature	-4°F to +140°F (-20°C to 60°C) No Heater -40°F to +140°F (-40°C to 60°C) With Optional Heater
Monitored External Entrapment Inputs	(2) close entrapment protection inputs and (2) open entrapment protection inputs

Installation

Site Preparation

Check local and national building codes BEFORE installation.

⚠ CAUTION

- BEFORE digging more than 18 inches (46 cm) deep, contact underground utility locating companies for information about underground lines to AVOID damaging gas, power, or other underground utility lines.
- When changing the battery or working around the battery compartment, ALWAYS wear protective gloves and eye protection to avoid contact with battery acid.

Gate

The gate must be constructed and installed according to ASTM F2200 standards (see page 9) and it must fit the specifications of the operator (see page 11).

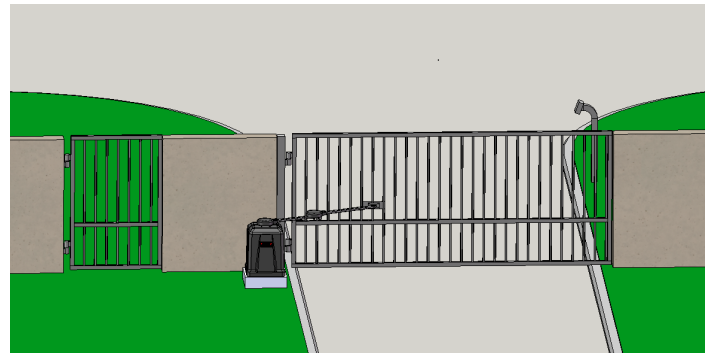

Trench

Before digging a trench for installation of conduit for wiring, contact your local underground utility locating companies. The conduit must be UL approved for both low and high voltage.

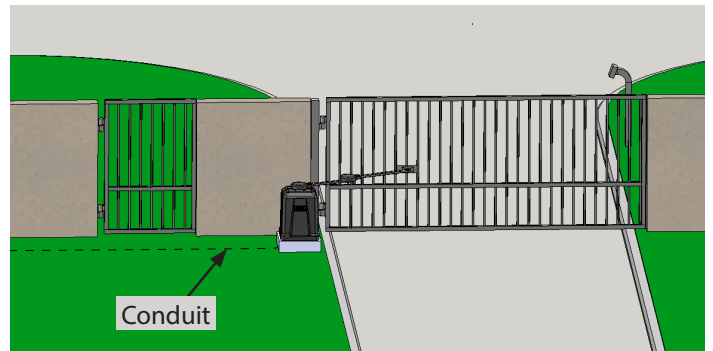

Accessories

Vehicle loops, which are recommended (but not required), allow the gate to stay open while a vehicle 14 feet (4.27 m) or longer is in the gate path. Complete a site survey before installation to determine the best Access Control Device for your site.

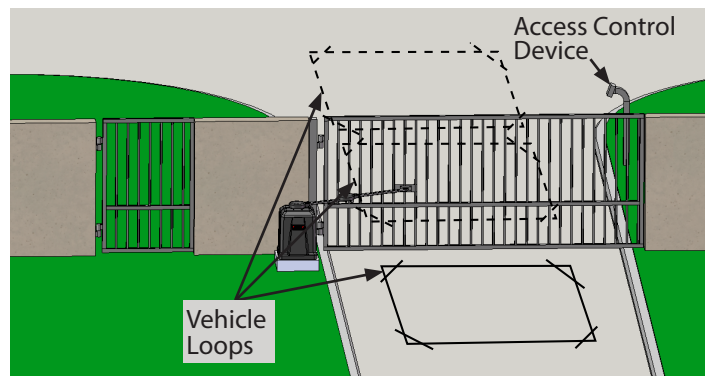

Safety

Entrapment protection devices are required to be installed to protect against entrapment or safety conditions found in your gate system. Install the two warning signs that are provided on both sides of the gate, where they are clearly visible.

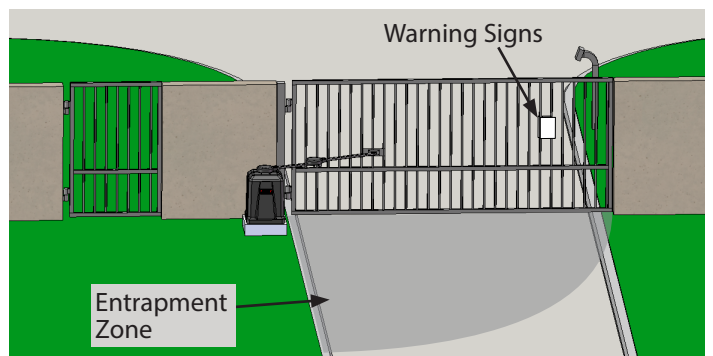

Installing the Operator

- Determine the location of the concrete pad in relation to the gate, according to the type of installation (see the following page).
 - Check local building codes before installation.
 - Install electrical conduit before pouring concrete.
 - Pour the concrete pad according to the dimensions shown.
 - The bottom of the pad must be below the frost line, or a minimum of 24" below grade. Check national and local building codes to determine where that is.
 - The top of the pad must be 6" above ground.
- Mark the location of the operator on the concrete pad, as shown on the following page.
- Drill for (4) 1/2" x 3-1/2" red head anchors in the locations shown below.

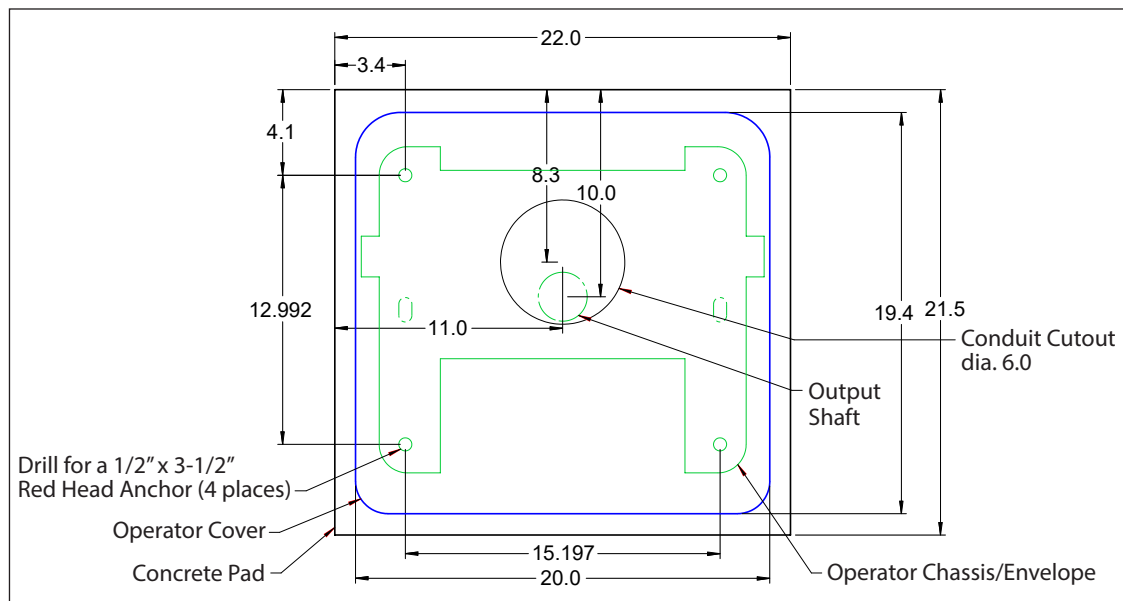
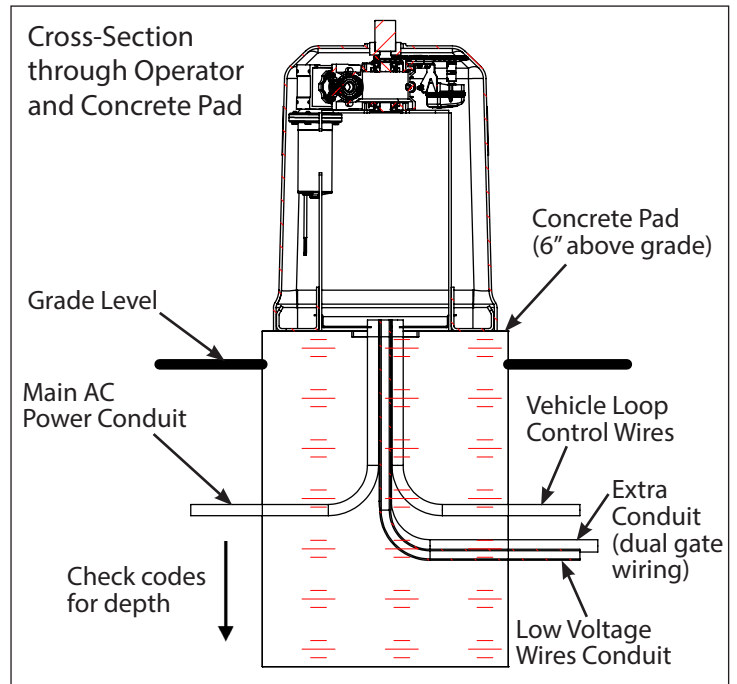

Installation

Determine Location for Concrete Pad

- The gate should be installed in a location to ensure enough clearance exists between the gate and an adjacent structure to reduce the risk of entrapment.
- The tables below show options for 90° (Chart A) and 110° gate travel (Chart B).
- The ideal measurements are the first row in the chart below (Option 1).
- Increasing "A" dimension provides better gate control and stability by reducing the effects of inertia and decreasing the gate leverage against the operator.
- Dimensions are based on a gate thickness of 2 inches (5.08 cm).
- Adjustments may be required based on installation (adjustments must only be made to B and C dimensions).

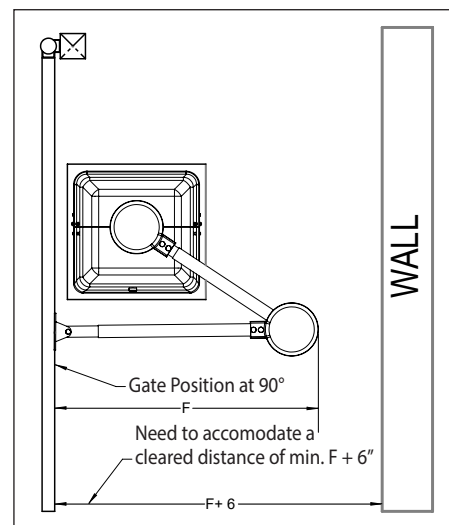
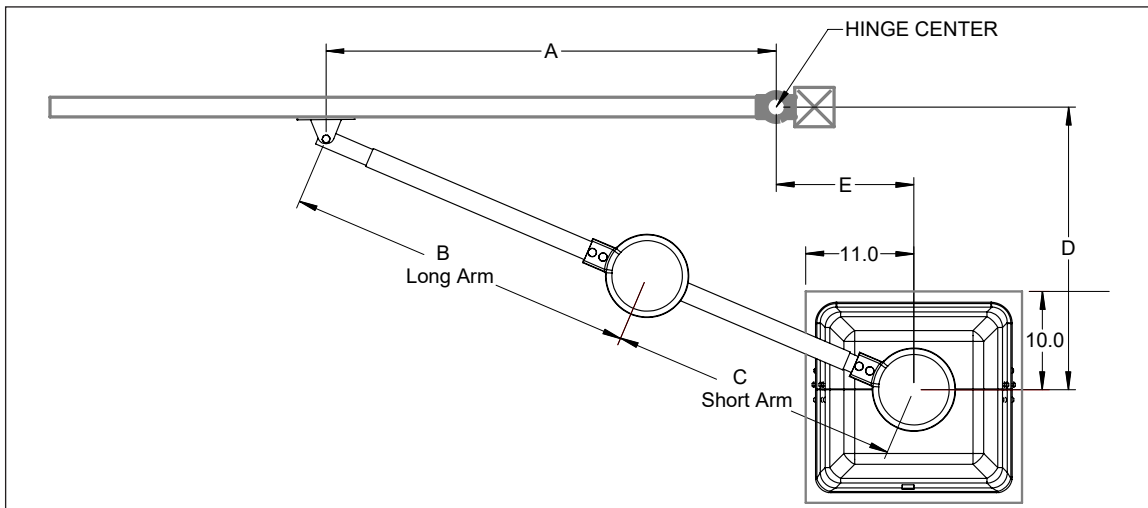

Chart A

Options	90° Gate Travel					
	A	B	C	D	E	F
1	45.5	35.5	29.5	29.25	14	47.75
2	44.25	35.75	28.5	30.25	14	48
3	47.5	34.25	31.5	26.25	14	46.75
4	48.25	38.25	31	33.5	14	50.5

Chart B

Options	110° Gate Travel					
	A	B	C	D	E	F
1	50	46.75	34	25.75	27.5	71.5
2	47.5	47	31	24.5	27.5	68

4. Attach the operator to the concrete pad with appropriate fasteners (not provided).
5. Install the clutch onto the output shaft so that the pin slides into the clutch's slot.

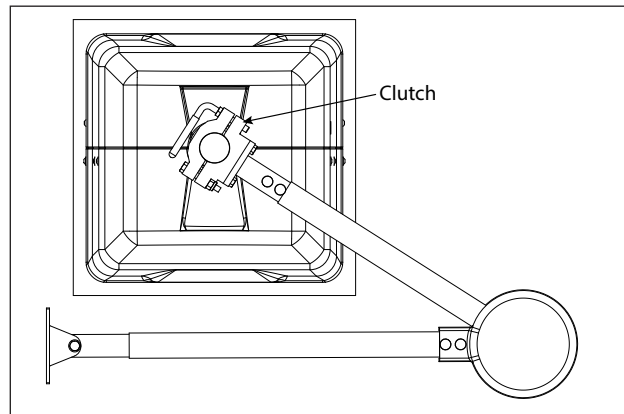

6. Prepare the articulated arm assembly to be installed on the operator.
 - Slide the short arm extension into the short arm to achieve the desired dimension (C) from Chart A or B.
 - Leave a min 3" overlap
 - Cut arm extensions if needed
 - Use set screws, pliers, C clamps to temporarily hold dimension C in place
 - Repeat the steps above for the long arm to achieve the desired dimension (B) from Chart A or B.
 - All dimensions must be consistent with the option chosen from Chart A or B (same row)
 - Assemble the short/long arms using the provided hardware as follows (from top - as shown below):
 - M12 x 90 bolt
 - M12 nylon washer
 - Long arm assembly
 - M12 nylon washer
 - Pinch guard
 - Short arm assembly
 - M12 nylon washer
 - M12 nut

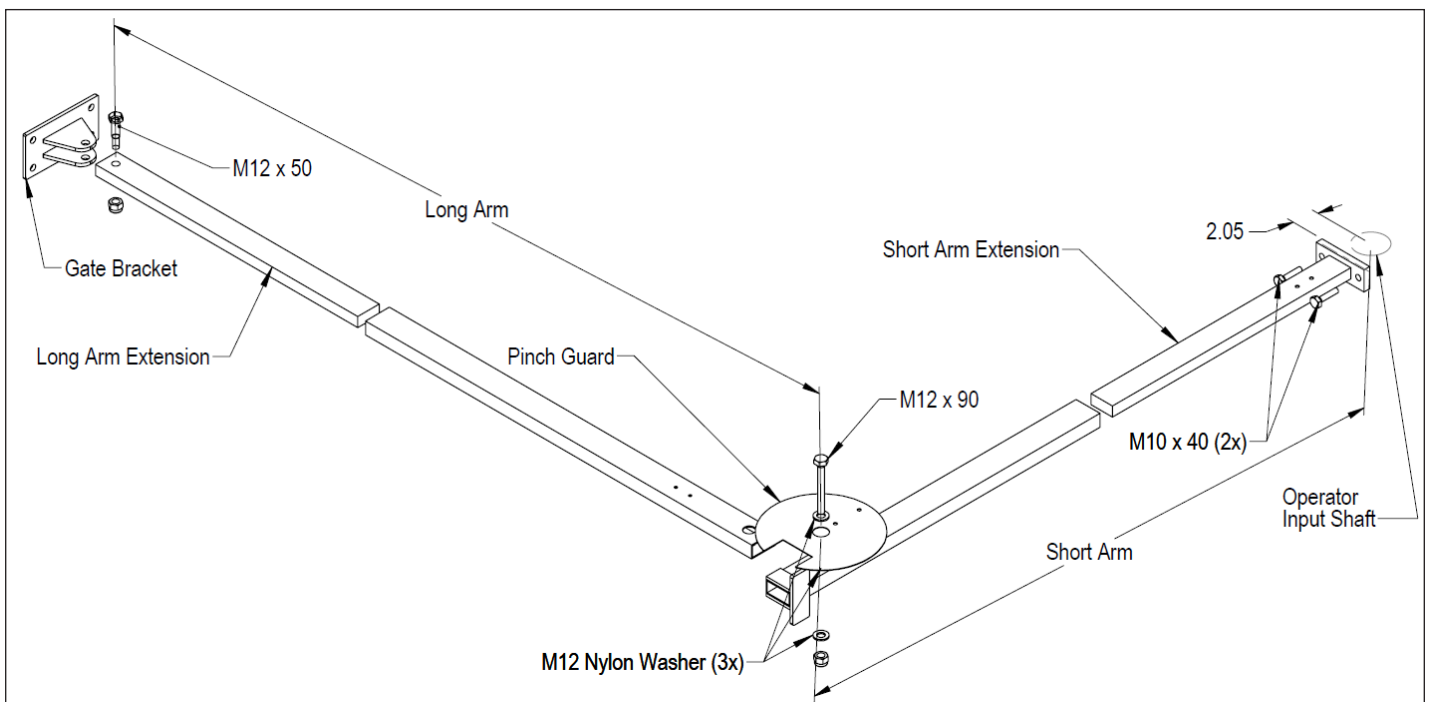

Installation

- Attach the articulated arm assembly to the clutch using two M10 x 40 screws (provided).
- With the clutch released, manually move the arm assembly toward the gate (gate is closed).
- Position the gate bracket to satisfy dimension A from Chart A or B, and arm assembly is level.
- Tack weld (bolt) the gate bracket in this position.
 - The gate bracket should be attached to a frame member
 - Attaching the gate bracket to only a few pickets can damage the gate during operation
- Open the gate halfway and connect the arm assembly to the gate bracket using a M12 x 50 bolt with a M12 nut (provided).
- Close the gate and make sure the arm assembly is fully extended, and at the same time reaches the physical stop. If not, adjust the length of the arms (Dimensions A and B) accordingly to meet these two requirements.

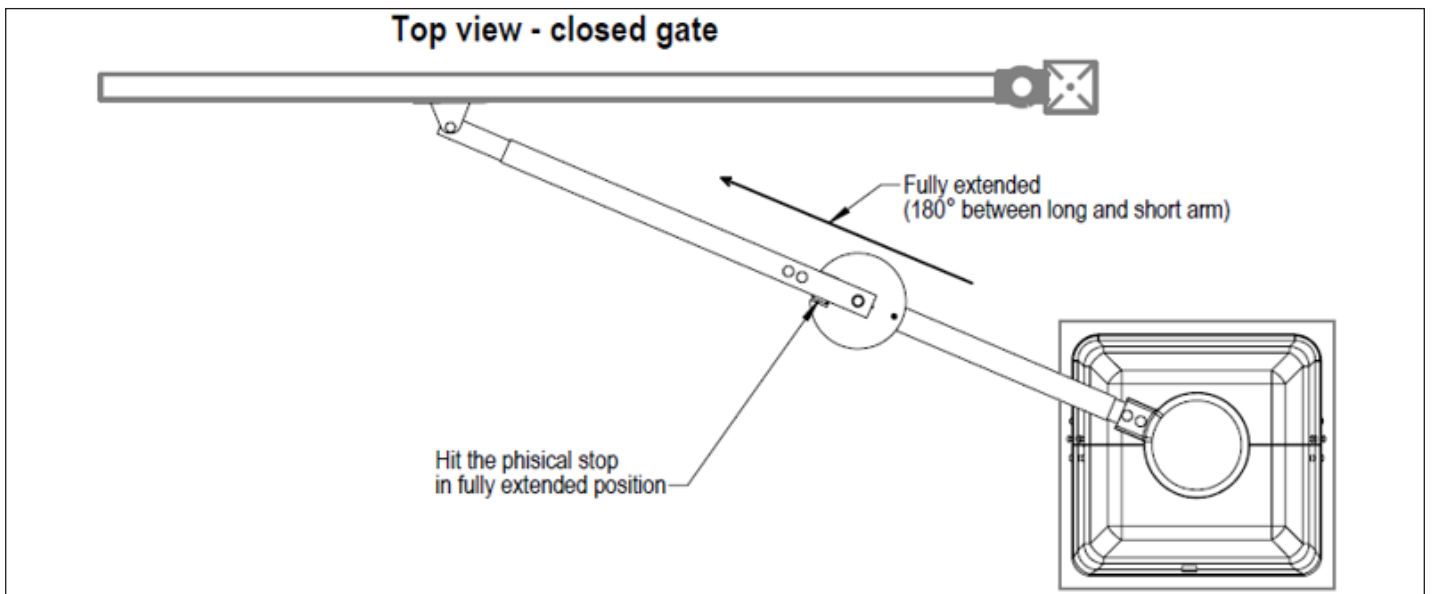

- Open the gate to 90°.
 - Make sure the arms won't scissor when open
 - Long arm should be approx. perpendicular to the gate in the open position as shown below left.
- If satisfied with the installation and the gate's movement, weld the components of the arm assembly securely. Paint the welded bead to protect against rust.
- Install the arm covers (2x) using two thumb screws for each cover (provided).

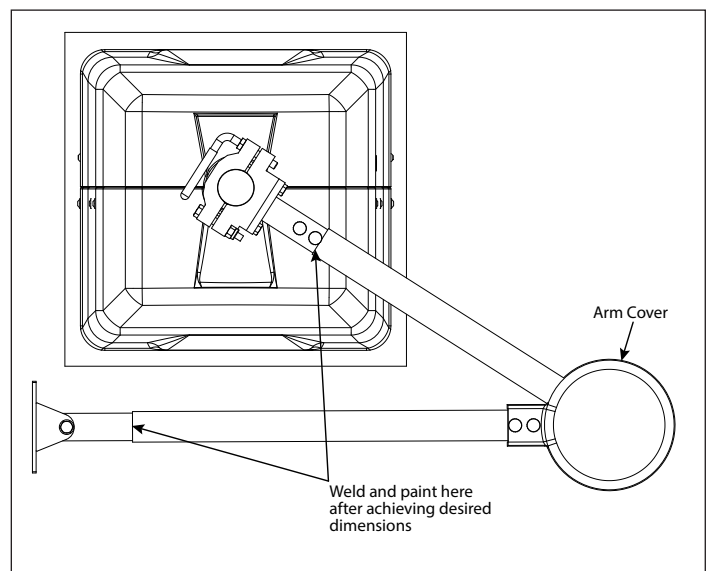
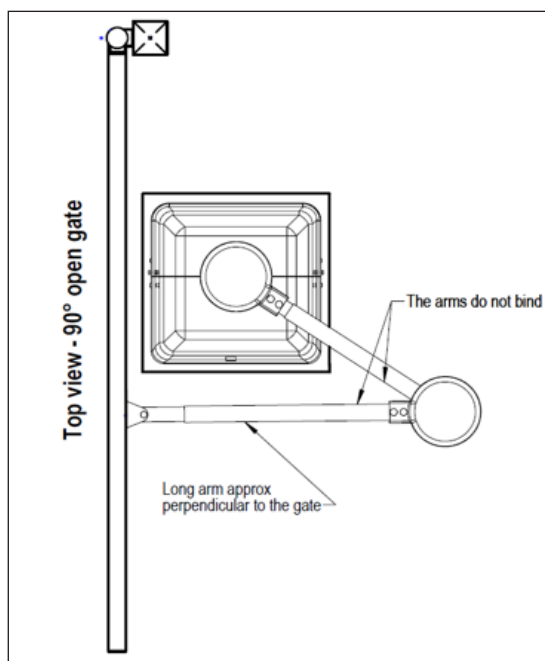

Control Box

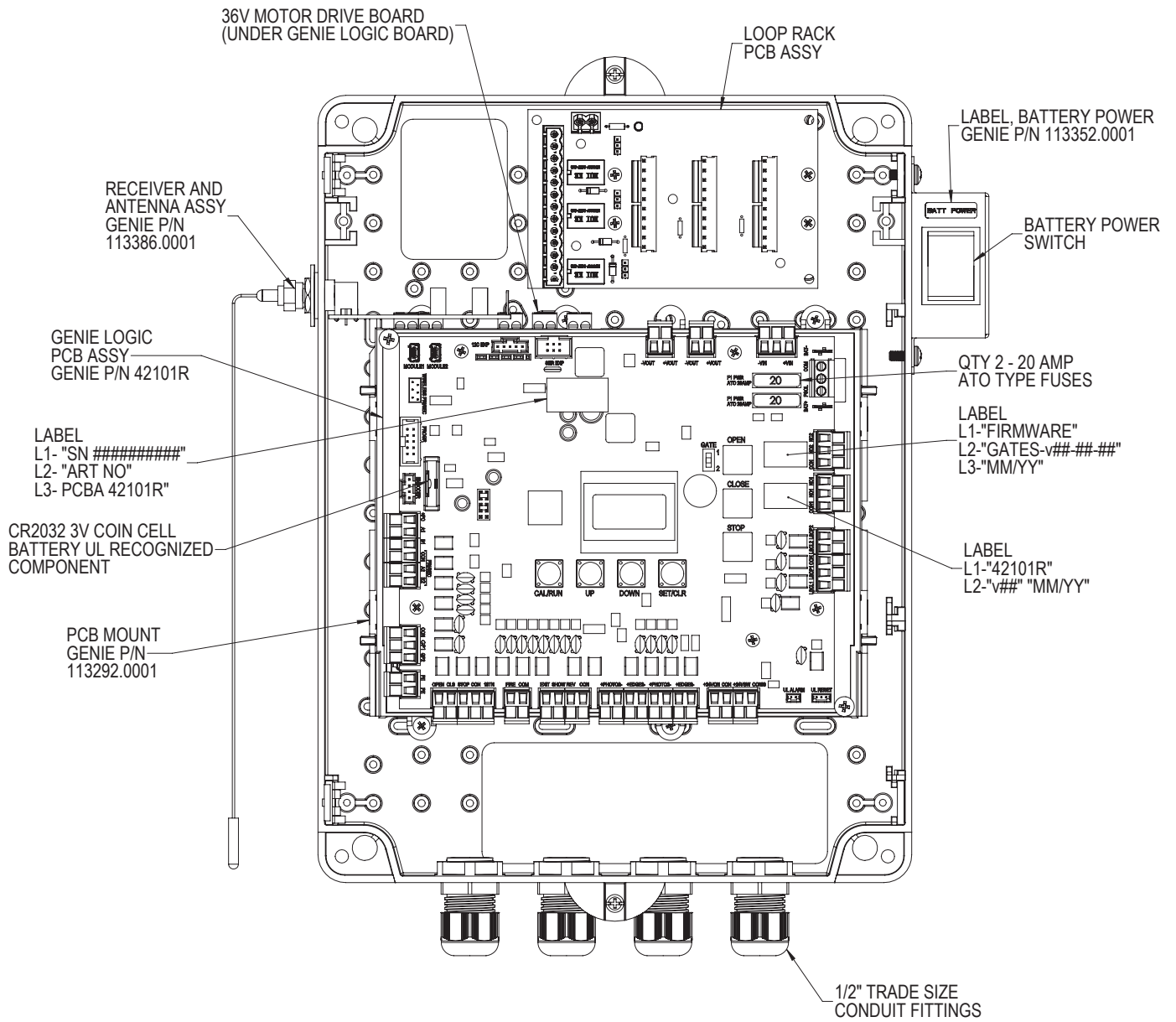

CONTROL BOX
SHOWN WITH COVER REMOVED

Installation

Manual Release

1. Loosen and remove the thumb screws on the arm cover on the operator, and remove the cover.
2. To enable manual operation, lift the clutch handle upwards. This will disengage the clutch.
3. To re-engage, lower the clutch handle back into position, parallel with the top of the clutch.
4. Replace the arm cover and thumb screws, and tighten the thumb screws.

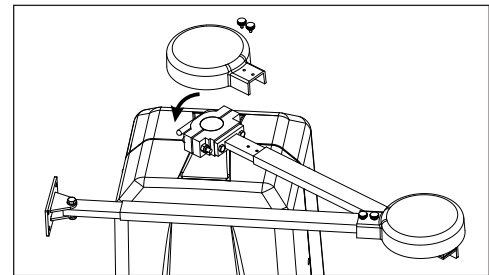
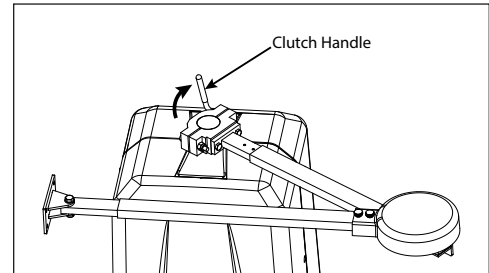
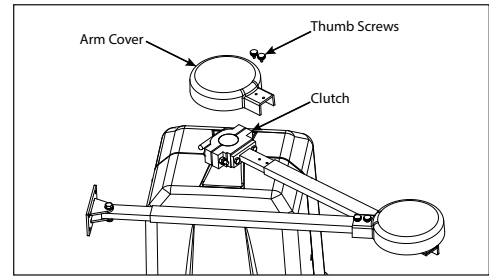

Install the Warning Signs

This gate operator is supplied with two warning signs that alert people that a possible hazard exists, and that appropriate actions should be taken to avoid the hazard, or to reduce exposure to it.

Install one warning sign on each side of the gate so that they are fully visible to traffic and pedestrians.

Use metal screws or cable ties (not supplied) to permanently install each warning sign.



THIS PAGE LEFT BLANK

Wiring the Operator

WARNING

To reduce the risk of SEVERE INJURY or DEATH:

- Before performing any maintenance near the operator, all electrical power must be disconnected, and lock out tag out procedures followed.
- Disconnect power at the fuse box BEFORE proceeding. Operator MUST be properly grounded and connected in accordance with national and local electrical codes. Failure to disconnect electrical power could result in death or serious injury.

NOTICE *The operator should be on a separate fused line of adequate capacity. Failure to use appropriate fusing and amperage will cause the fuse to trip or permanently damage the operator.*

- All electrical connections MUST be made by a qualified individual.
- DO NOT install ANY wiring or attempt to run the operator without consulting the wiring diagram.
- ALL power wiring should be on a dedicated circuit and well protected. The location of the power disconnect should be visible and clearly labeled.
- ALL power and control wiring MUST be run in a separate conduit.

AVERTISSEMENT

Pour réduire les risques de blessures graves ou de décès:

- Avant d'effectuer toute opération de maintenance à proximité de l'opérateur, il convient de couper l'alimentation électrique et de suivre les procédures de verrouillage et d'étiquetage.
- Débranchez l'alimentation électrique au niveau de la boîte à fusibles AVANT de procéder. L'opérateur DOIT être correctement mis à la terre et connecté conformément aux codes électriques nationaux et locaux. Le fait de ne pas débrancher l'alimentation électrique peut entraîner la mort ou des blessures graves.

AVIS

L'opérateur doit être branché sur une ligne séparée avec fusible et de capacité adéquate. Si les fusibles et l'ampérage ne sont pas appropriés, le fusible se déclenchera ou l'opérateur sera endommagé de façon permanente.

- Toutes les connexions électriques DOIVENT être effectuées par une personne qualifiée.
- NE PAS installer de câblage ou essayer de faire fonctionner l'opérateur sans consulter le schéma de câblage.
- TOUT le câblage d'alimentation doit être sur un circuit dédié et bien protégé. L'emplacement du dispositif de déconnexion doit être visible et clairement identifié.
- TOUS les câbles d'alimentation et de commande DOIVENT être placés dans un conduit séparé.

⚠ WARNING

- DO NOT apply power to operator until instructed to do so.
- It is strongly recommended, and may be required by law in some areas, that line voltage wiring be performed by a qualified electrician.
- Be sure that electrical power has been disconnected from the input power wires being connected to the operator prior to handling these wires. An appropriate lock-out/tag-out procedure is recommended.
- Line voltage wiring must meet all local building codes.
- Make sure operator voltage, phase and frequency nameplate ratings are identical to the job site line voltage ratings.
- Input power wiring must be properly sized for the operators amperage rating located on the nameplate.
- To reduce the risk of electric shock, make sure the chassis of this unit is properly grounded.

⚠ AVERTISSEMENT

- NE PAS mettre l'opérateur sous tension avant d'en avoir reçu l'instruction.
- Il est fortement recommandé, et peut être exigé par la loi dans certaines régions, que le câblage de la tension de ligne soit effectué par un électricien qualifié.
- Assurez-vous que l'alimentation électrique a été déconnectée des fils d'entrée connectés à l'opérateur avant de manipuler ces fils. Il est recommandé d'appliquer une procédure de verrouillage/étiquetage appropriée.
- Le câblage de la tension de ligne doit être conforme à tous les codes de construction locaux.
- Assurez-vous que la tension, la phase et la fréquence indiquées sur la plaque signalétique de l'opérateur sont identiques à celles de la tension secteur du chantier.
- Le câblage d'alimentation doit être correctement dimensionné pour l'intensité nominale de l'opérateur indiquée sur la plaque signalétique.
- Pour réduire le risque d'électrocution, assurez-vous que le châssis de l'appareil est correctement mis à la terre.

Line Voltage Wiring

For optional solar applications, refer to the Wiring Diagram on page 25.

1. Turn off the AC power from the main power source circuit breaker.
2. Run the AC power wires to the control box.
3. Remove the cover from the junction box.
4. Using the wire nuts included, connect the line voltage wires and Ground terminal.
5. Replace the junction box cover. Make sure that the wires are not pinched.

NOTICE Do not apply AC power until you have confirmed that all wires are installed correctly. If wiring is not terminated to the appropriate terminals, applying AC power will damage the operator.

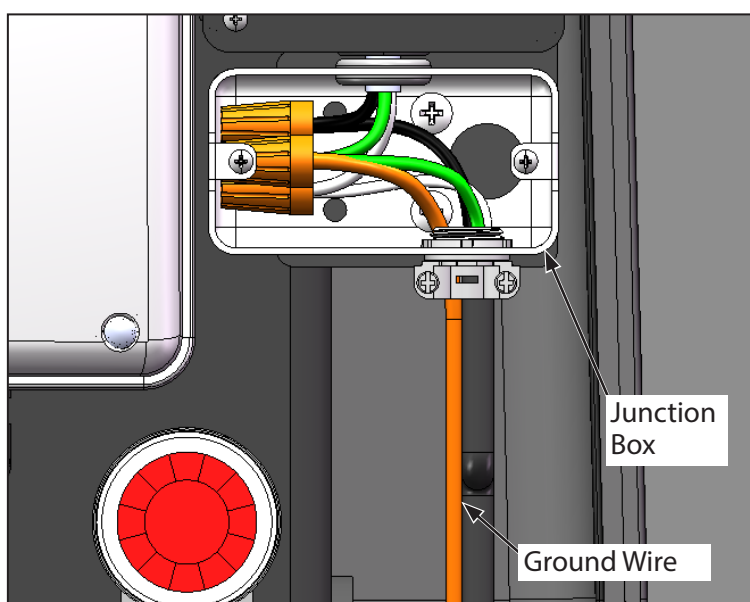

Wiring

Wiring Diagram

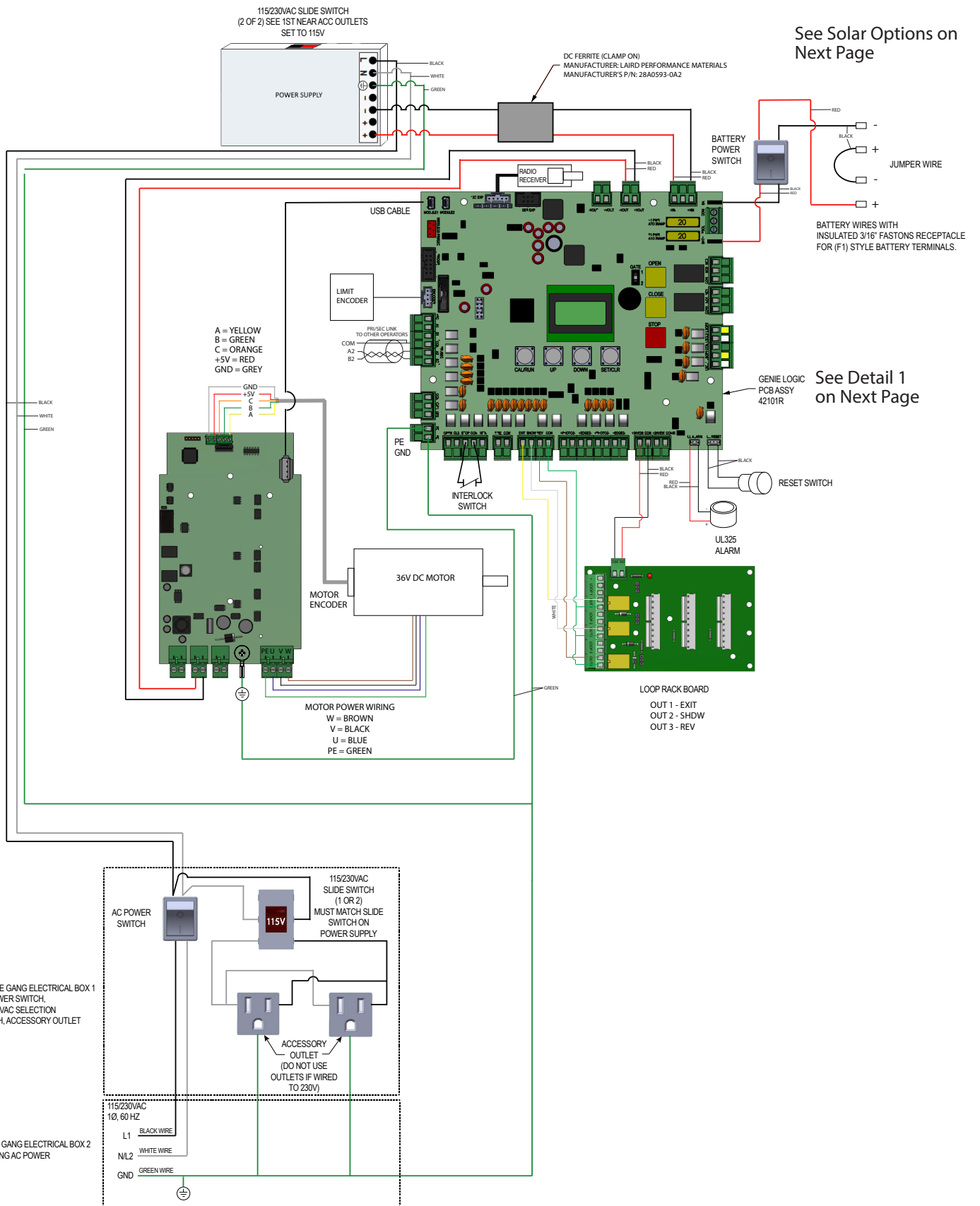

Detail 1

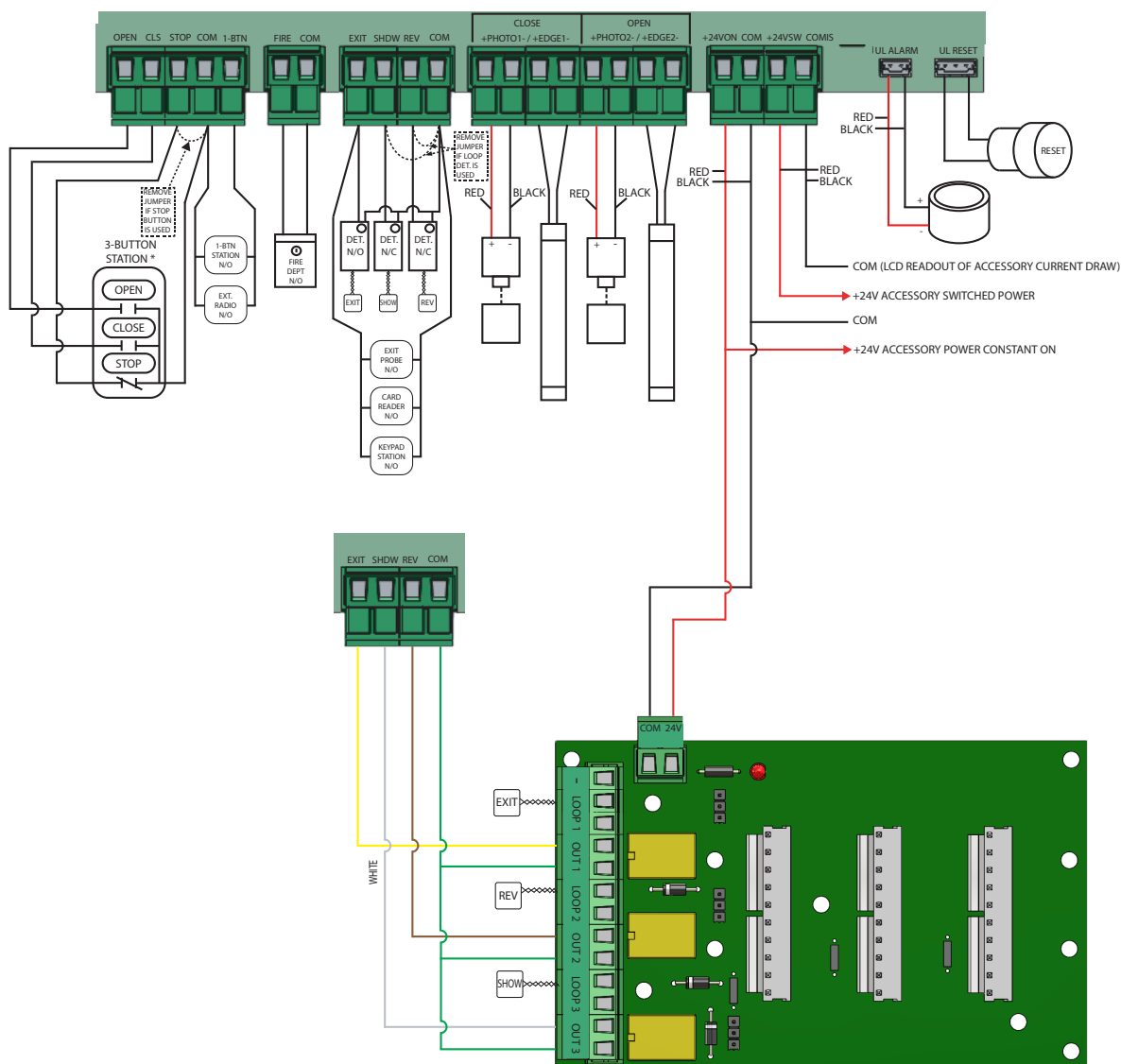

Solar Options (see pages 44-45)

HIGH POWER CONFIGURATION-UP TO 90W EXTERNAL CHARGE CONTROLLER

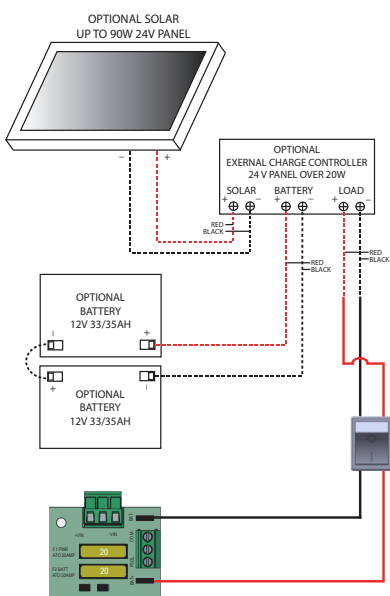

LOW POWER CONFIGURATION-UP TO 90W EXTERNAL CHARGE CONTROLLER

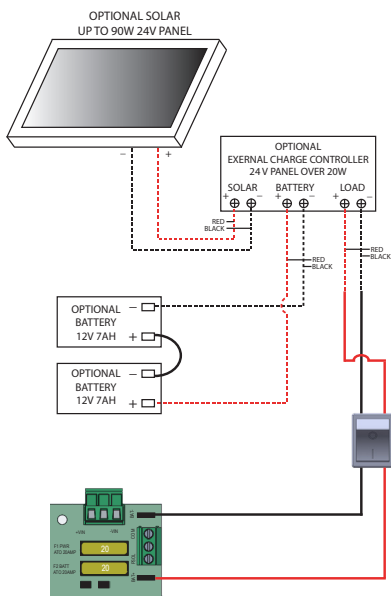

LOW POWER CONFIGURATION-20W ONBOARD SOLAR CHARGER

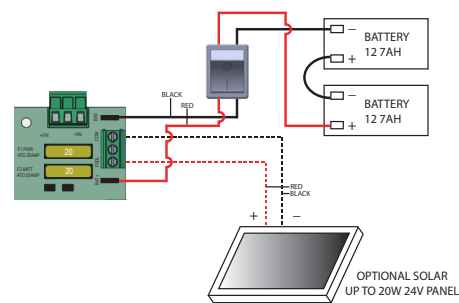

Wiring

Earth Ground Rod (Not Provided)

NOTICE Use of an earth ground rod is strongly recommended. Failure to ensure the operator is properly grounded could result in performance impact or permanent damage to the operator.

The earth ground rod must be the proper type for your area. The ground wire must be a single piece of solid wire; if it is damaged in any way, replace it with a single wire length.

1. Install the earth ground rod within 3 feet (.9 m) of the control box.
2. Run the wire from the earth ground rod to the control box. See “Line Voltage Wiring” on page 21 for instructions on connecting the ground wire.

NOTICE *Grounding the operator properly ensures that the range of the remote controls will be adequate.*

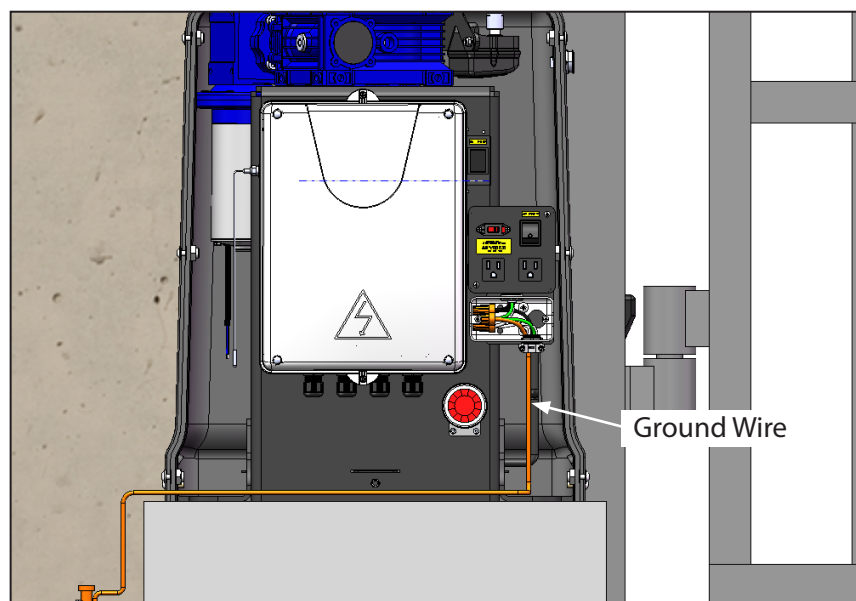
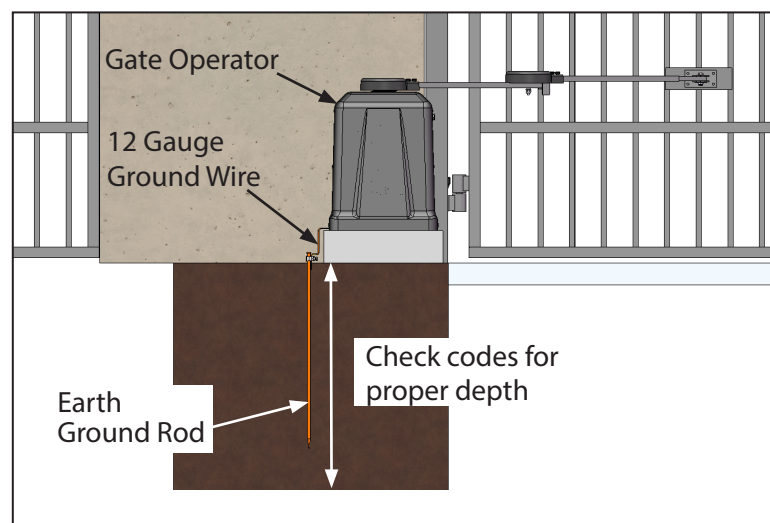

Install Entrapment Protection

Entrapment is defined as the condition when an object is caught or held in a position that increases the risk of injury. The minimum number of external entrapment protection sensors required in a typical automated gate installation will depend on the type of operator, the type of gate, and the number of entrapment zones that require protection.

At least two means of entrapment protection are required in each direction of travel for most installations. For any and all installations in which a direction has a risk of entrapment, at least two independent means of entrapment protection are required.

- **ENTRAPMENT ZONE HAZARD** – Gates must be equipped with entrapment protection if their motion toward a stationary object, such as a wall or fence, results in a gap less than 16 inches in the direction of travel. Body parts positioned between the gate and stationary object can result in serious injury or death.
- Pedestrians must stay clear of the gate path and any area where gate motion is close to stationary objects.
- **PINCH POINTS HAZARD** - The opening mechanism may have arms that can overlap with a scissoring effect, which can result in serious injury. Pedestrians must stay clear of the opening mechanism at all times, particularly when the gate is opening.



WARNING Failure to install required entrapment protection will result in death or serious injury.

Entrapment Protection Devices

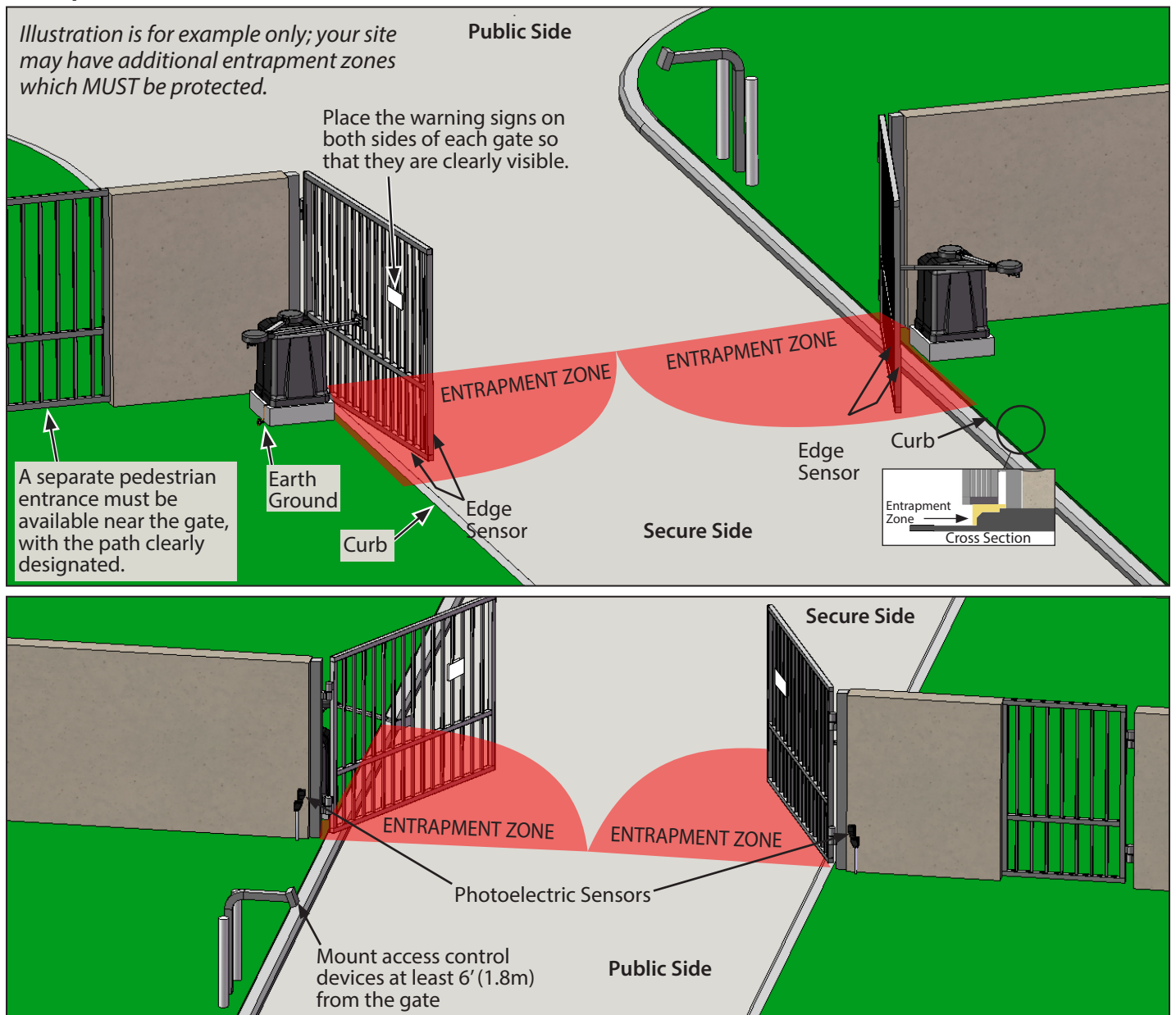

Wiring

Wiring Entrapment Protection Devices

Attach the photoelectric sensors (red (+) and black (-) wires) to the corresponding inputs on the control board as shown in the diagram.

Attach 10k ohm monitored sensing edge(s), if required, to the corresponding inputs on the control board as shown in the diagram.

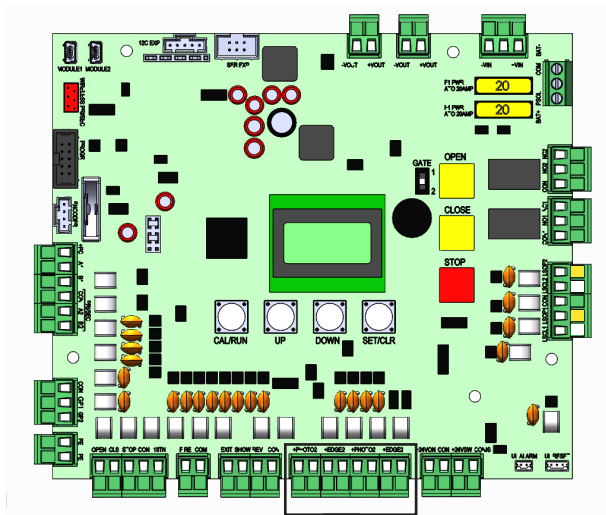

CONTROL BOARD

NOTICE

To go into momentary contact (automatic operation) each swing gate operator requires at least one monitored entrapment device wired in the close direction and it must be unobstructed before automatic operation will be enabled.

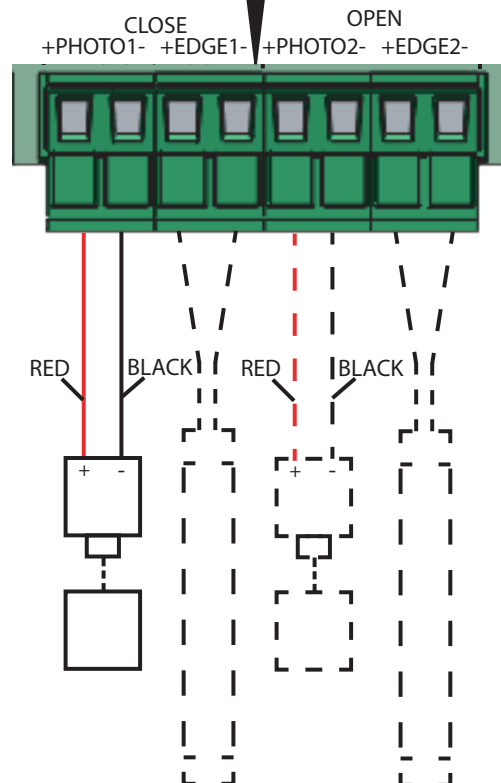

NOTICE

If there are entrapment zones in the open direction of travel then additional monitored entrapment device(s) must be wired into the open direction.

Retro-Reflective Photoeye Kit (Included)

⚠ WARNING

TO PREVENT POSSIBLE SERIOUS INJURY or DEATH from electrocution AND REDUCE RISK of FIRE — Disconnect ALL electric power sources and battery power BEFORE performing ANY service or maintenance.

Installation

Install the photoelectric sensor so that the center of the sensor window is a minimum of 21" (53 cm) or a maximum of 27.5" (70 cm) above grade. Photoeyes must be within 5" (12.7 cm) from the face of the front plane of the gate.

IMPORTANT:

- Disconnect all power to the operator before proceeding.
 - Mount the sensors vertically.
1. Mount the photo eye bracket assembly to the desired mounting surface with 14-10 x 1.00 screws. Drill a wire access hole in the desired mounting surface through the center hole in the bracket (if desired).
 2. Position the sensor assembly into the bracket assembly and attach the top bracket with 8-16 x 1.00" thread locking screws, finger tight to allow for adjustments.
 3. Mount the rain guard on to the sensor back plate. Make sure it locks into place on the protrusions. Secure the rain guard with a 6-32 thumb screw.
 4. Route the cable as desired to the control box. Two 3/4" to 1/2" reducer washers are provided for 1/2" NPT fitting method. (NPT fitting is not provided.)
 5. Install the reflector into the rain guard.
 6. Mount the rain guard and reflector to the reflector bracket with 8-32 x .63" screws and lock nuts.
 7. Mount the reflector bracket to the desired mounting surface with 12-11 x 1.00 screws.
 8. The reflector must be a minimum of 3 ft. (.9 m) and a maximum of 45 ft. (14 m) away from the sensor. Make sure the sensor and reflector are mounted at the same height.

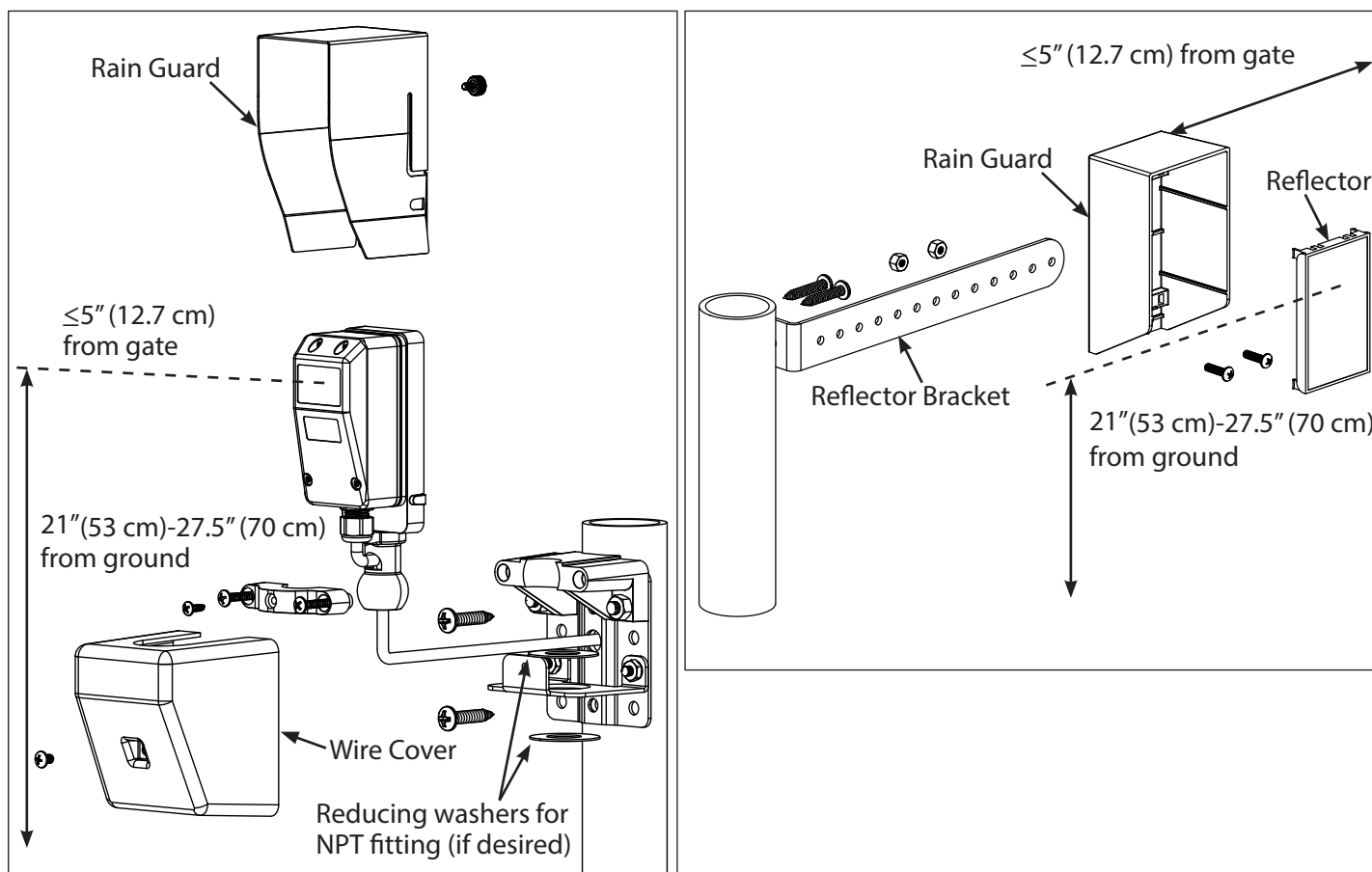

Wiring

Alignment

Apply power to the operator.

1. Align the sensors. The LED indicates that power is available. The red LED indicates signal strength. 2 blinks indicates an obstructed beam or the beam is out of alignment. Solid yellow LED indicates optimal alignment.

NOTICE No LEDs on indicates the sensors are not powered.

2. Once the sensors are properly aligned, tighten the sensor bracket screws. Tighten with the set screw to ensure a good grip.
3. Install the wire cover onto the sensor bracket, sliding the tabs on the inside of the wire cover underneath the flange on the sensor mounting bracket. Use the 8-32 x 3/8" screw to secure the wire cover. Do not use the wire cover with a conduit installation.

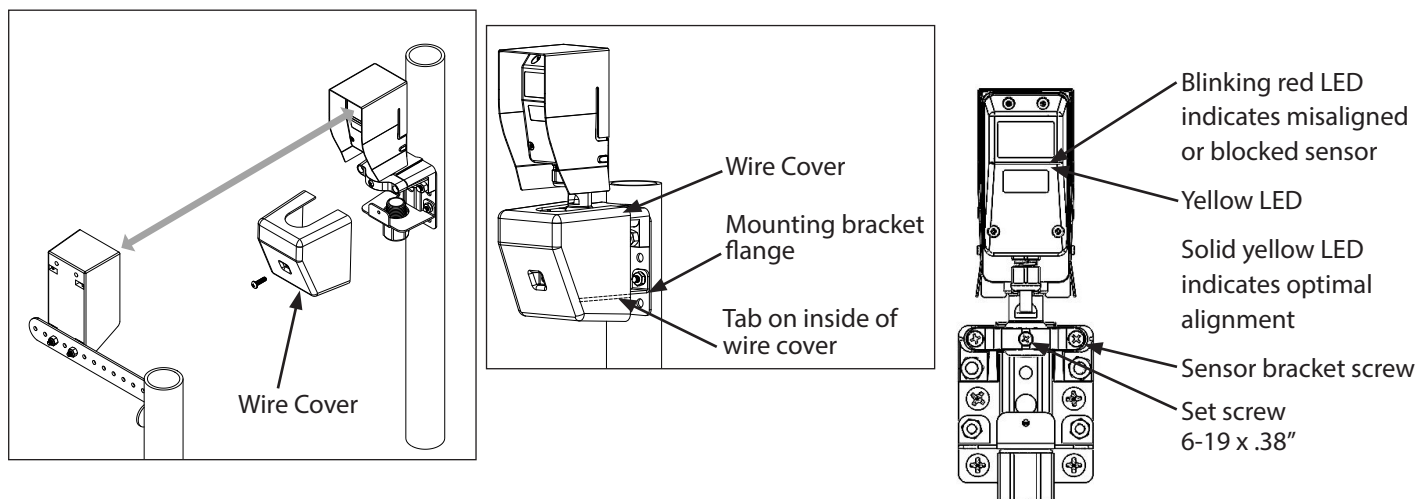

Test

To test the sensors, place an object in the sensor beam path and run the operator. If the gate does not stop and reverse, refer to the Troubleshooting chart below. Perform the test with the obstruction in three locations:

- Halfway between the reflector and sensor
- Near the sensor
- Near the reflector

When obstructed, the following will be observed:

- Closing Direction – If the gate is moving, breaking the beam will result in the gate stopping and reversing direction within two seconds. The gate will travel to the full open limit.
- Opening Direction – If the gate is moving, breaking the beam will result in the gate stopping and reversing direction within two seconds. The gate will travel a minimum of two inches and then stop.
- If the gate is stationary and the eye is obstructed, the gate will not move.

Troubleshooting

RED LED	YELLOW LED	Possible Problem	Solution
OFF	ON SOLID	Normal Operation	None required
OFF	OFF	Operator not powered Wiring from operator bad	Check breakers, fuse, plugs Check wiring for shorts
2 BLINKS	OFF	Beam obstructed Beam not aligned	Check for obstruction Check sensor, sensor alignment Contact customer support
OFF	4 Hz BLINKING	Beam not properly aligned	Check sensor Check sensor/reflector alignment Contact customer support

LED Blink Rate: 2 Blinks -> ON 200ms, OFF 200ms, ON 200ms, OFF 500ms, REPEAT

Operator Setup Procedures

Control Board Programming

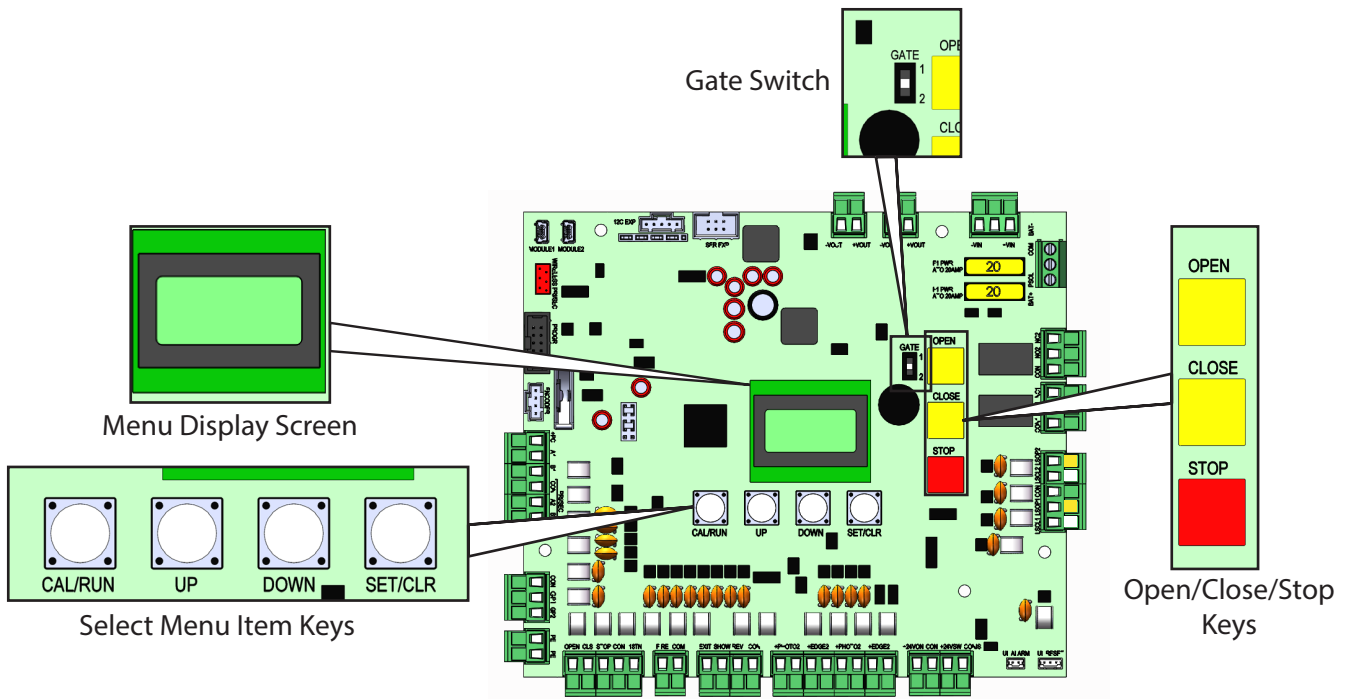

The operator includes a full function control panel including a liquid crystal display (LCD), calibration keys, and Open, Close, and Stop keys for on board operator control (see above). The Menu Display will show current operator conditions and calibration information. Due to limited character space, some displays scroll to display the full text.

NOTICE

Do not apply AC power until you have confirmed that all wires are installed correctly. If wiring is not terminated to the appropriate terminals, applying AC power will damage the operator.

Control Operating Modes

Operator control boards operate in two modes: Run Mode and Calibration Mode. The control board should normally operate in the Run Mode. The operator is calibrated in Calibration Mode.

With the operator standing idle and the display screen dark/off:

1. PRESS CAL/RUN TO TOGGLE BETWEEN OPERATING MODES. The first press of the CAL/RUN key will wake the display screen. The backlight will illuminate green.

The display will be in RUN MODE and will display the current status (example-"IDLE-CLOSE LIMIT").

2. Press the CAL/RUN key a second time to put the operator in Calibration Mode.
 - The first display in calibration mode is Menu Item #2: Set Gate Direction.
 - Pressing the CAL/RUN key again will display MENU #24.
 - Pressing the CAL/RUN key a fourth time will take the display back to RUN MODE.

Menu Item #2 - Set Gate Direction

Disengage the motor (see page 19) and manually move the gate to the half open/closed position. Re-engage the motor (see page 29).

1. Navigate to Menu Item 2 using the UP/DOWN keys.

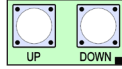

2. Press the SET/CLR key.



3. The screen will display HIT SET/CLR TO ENTER THIS MODE.



4. Press the SET/CLR key.



5. The screen will display "SET DIR1-PRESS CLOSE KEY BRIEFLY TO TEST".

Press and hold the CLOSE key 1-3 seconds until the gate briefly runs.

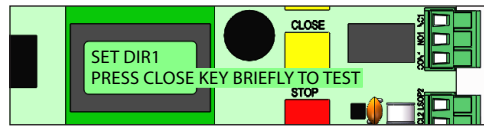

6. The screen will display "DID GATE CLOSE". If the gate moves towards the CLOSE limit, select YES by using the UP/DOWN keys (if necessary).

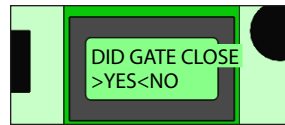
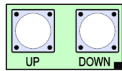

When it displays ">YES<", press the SET/CLR key to confirm YES.



7. The menu will move automatically to Menu Item 3 - OPEN LIMIT (page 37).

Operator Setup Procedures

Menu Item #3 - Open Limit

1. Press the SET/CLR key.
2. The screen will display "CLEAR".
3. Press the OPEN key on the control board. The gate will start moving in the open direction. When the gate has reached the desired open limit, release the open key. Press the SET/CLR key. The screen will display "SET".
4. When setting the open limit it is important that the gate has last traveled in the opening direction. If the gate goes beyond the desired position for the open limit, do not press Close to bring it back to the desired point. Instead use the Close key to bring the gate about six inches past the desired close limit, and then use the Open key to open the gate to the desired limit. This will improve the accuracy of the open limit.

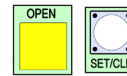

Menu Item #4 - Close Limit

1. Press the SET/CLR key.
2. The screen will display "CLEAR".
3. Press the CLOSE key on the control board. The gate will start moving in the close direction. When the gate has reached the desired close limit, release the close key. Press the SET/CLR key. The screen will display "SET".
4. When setting the close limit it is important that the gate has last traveled in the closing direction. If the gate goes beyond the desired position for the close limit, do not press Open to bring it back to the desired point. Instead use the Open key to bring the gate about six inches past the desired Open limit, and then use the Close key to close the gate to the desired limit. This will improve the accuracy of the close limit.

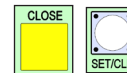

Menu Item #5 - Reversing Force Gate #1

NOTICE *If using primary/secondary, skip to Menu Item #10 on page 35. Return to this point when finished.*

1. Press the SET/CLR key to enter the menu. The current value will be displayed.
2. Press the UP key to increase the percentage of force in increments of 5% between 10 and 80 (default is 30%). Press and hold the key for 2 seconds for High Speed Scroll.
3. Decrease the force setting by pressing the DOWN key. It will be displayed in increments of 5% between 80 and 10. Press and hold the key for 2 seconds for High Speed Scroll.
4. Press the SET/CLR key to accept the setting and exit the menu item.



Menu Item #6 - Timer to Close

This closes the gate automatically, based on the timer setting after an open cycle is completed.

1. Press the SET/CLR key to enter the menu. The current value will be displayed. OFF is the default setting.
2. Press the UP key to increase the time in increments of 1 second between 1 and 240. Press and hold the key for 2 seconds for High Speed Scroll.
3. Press the DOWN key to decrease the time in increments of 1 second between 240 and 1. Press and hold the key for 2 seconds for High Speed Scroll.
4. Press the SET/CLR key to accept the setting and exit the menu item.



Optional Transmitter Programming

250 Genie Intellicode® remote controls or keypads, and 2 key-less entries (1 PIN for each) can be programmed to the operator.

When the operator's memory is full, it will exit the programming mode and the transmitter will not be programmed. Erase the memory before programming any more transmitters.

Menu Item #7 - Learn New Transmitter

1. With the display backlight dark, press the CAL/RUN key 2 times.



2. Press the UP/DOWN keys until the display reads "MENU 7". Press the SET/CLR key to enter the menu.

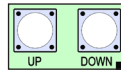

Display will read "LEARN NEW XMTR?" on the top line, and "HIT SET/CLR FOR YES" on the second line.

3. Press the SET/CLR key.



- Display will read "PUSH XMTR BUTTON TWO TIMES TO LEARN XMTR" on the second line.

4. Press the Transmitter button two times.

- Display will read "LEARNED XMTR ###" on the second line, which is a random number between 1 and 250. That transmitter is entered and ready to operate the gate. Label or mark the transmitter.

5. The display will return to "MENU 7 LEARN NEW XMTR?".

Repeat the process above to learn another transmitter, or press the UP/DOWN keys to move to another menu item. Press the CAL/RUN key to exit the calibration mode.

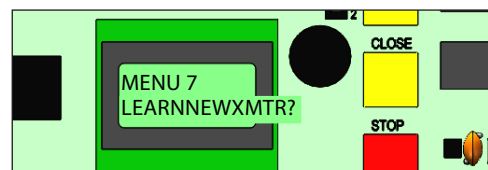
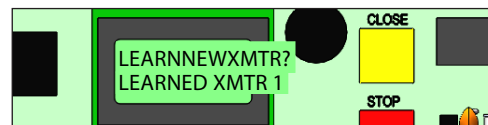
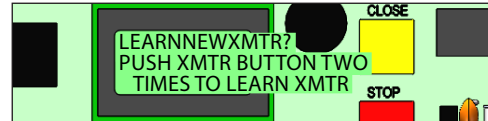
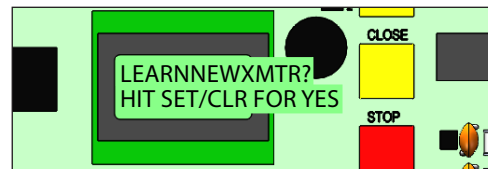
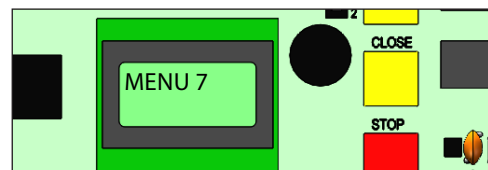
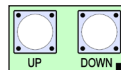

Operator Setup Procedures

Menu Item #8 - Remove a Single Transmitter

1. With the display backlight dark, press the CAL/RUN key 2 times.



2. Press the UP/DOWN keys until the display reads:
"MENU 8
REMOVE SINGLE XMTR?"

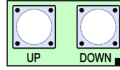

- This question, as well as the instruction "HIT SET FOR YES" will continuously pan across the display window. Pressing UP/DOWN or CAL/RUN will cancel the operation.

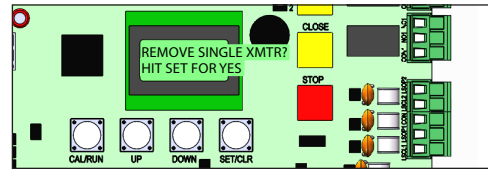
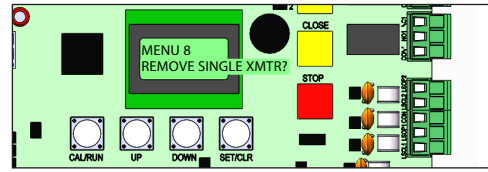

3. Press the SET/CLR key.



- A menu displaying the available transmitter numbers will appear. Press the UP/DOWN keys to cycle through the menu to the number of the transmitter to be removed. Pressing CAL/RUN will cancel the operation.

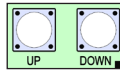

4. Press the SET/CLR key.

- The transmitter is removed.

5. Press the UP/DOWN keys to move to another menu item, or the CAL/RUN key to exit the CAL mode.

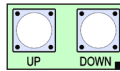

Menu Item #9 - Remove All Transmitters

1. With the display backlight dark, press the CAL/RUN key 2 times.



2. Press the UP/DOWN keys until the display reads:
"MENU 9
REMOVE ALL XMTRS?"

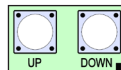

- This question, as well as the instruction "HIT SET FOR YES" will continuously pan across the display window. Pressing UP/DOWN or CAL/RUN will cancel the operation.

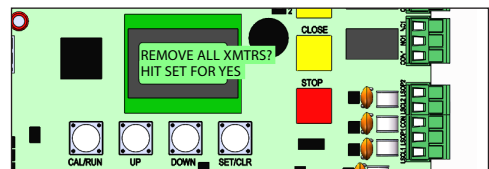
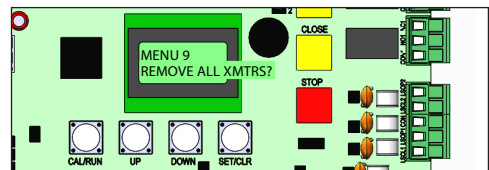

3. Press the SET/CLR key.



- The display will read "ARE YOU SURE?"

4. Press the SET/CLR key.



- All transmitters are removed.

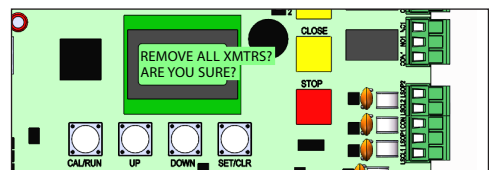

5. Press the UP/DOWN keys to move to another menu item, or the CAL/RUN key to exit the CAL mode.

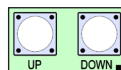

Operator Setup Procedures

Menu Item #10 - Set Primary & Secondary Gates (Wired or Wireless setups)

Allows the pairing of two operators to allow biparting operator driven from the primary operator.

To ensure proper functionality, Menus 1-4 must be configured on both the primary and secondary operator before enabling this feature.

NOTICE

1. The primary and secondary operator must be enabled one of the following two ways:
 - a. Wire the primary and secondary operators together using the A2, B2, and C terminals.

PRI	SEC
A2	A2
B2	B2
COM	COM

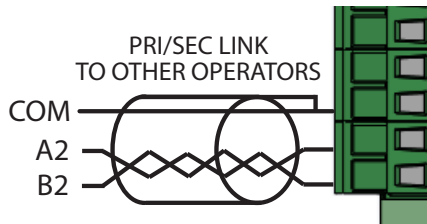

NOTICE

For wired connection, use 20 to 24AWG twisted pair shielded cable. The drain wire should be connected, along with the COM wire, to the COM terminal on the Primary side only.

- b. Connect the optional wireless primary/secondary module to the WIRELESS PRI/SEC port on the Gate Control Board.

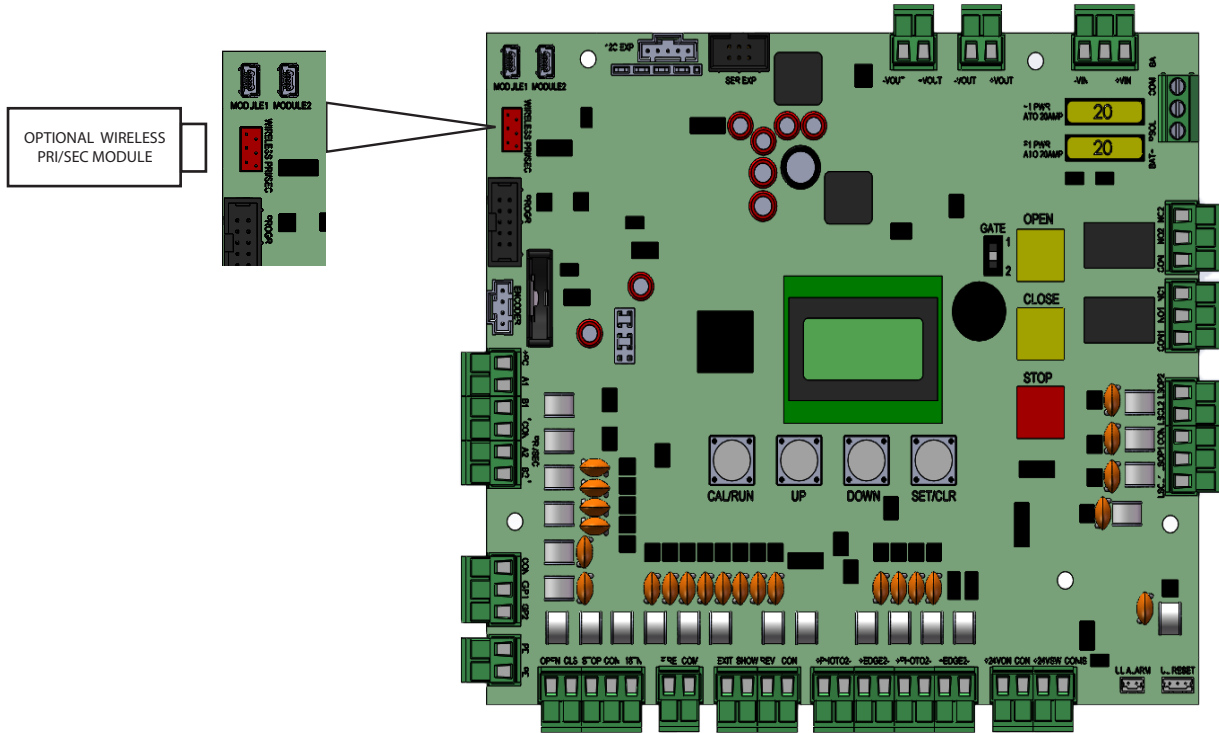

2. Press the CAL/RUN button to enter calibration mode on the operator intended to be used as the secondary.
3. Use the UP/DOWN keys to navigate to Menu Item #10 and enter with SET/CLR.
4. Change the setting from OFF to SEC WIRED or SEC WLESS, depending on the setup being used, and exit the menu.
5. Repeat steps 2 and 3 on the operator intended to be used as the primary.

Operator Setup Procedures

6. Change the setting from OFF to PRI WIRED or PRI WLESS, depending on the setup being used, and exit the menu.

NOTICE *Menu 5 must be configured after this setting is configured.*

NOTICE *All entrapment protection devices should be wired to the primary operator.*

NOTICE *If the operator is set to secondary, menus listed below will not be available and must be configured on the primary operator logic board.*

NOTICE *If an install has 2 gates and primary/secondary mode is active and the secondary gate is not working, primary/secondary mode needs to be set to off on the primary operator in order to operate the working gate.*

Menu item #	Function	Menu item #	Function
6	Timer To Close	27	Anti-Tailgating
7	Learn New XMTR ?	28	GP1
8	Remove XMTR	29	GP2
9	Remove All XMTRs	30	COMIS
11	Bi-Parting Delay	31	Date And Time
17	24V SW	32	Daylight Savings Time
21	Photo 1 Type	33	Clock 1
22	Photo 2 Type	34	Clock 2
23	Photo 1 Dir	35	Clock 3
24	Photo 2 Dir	36	Clock 4
25	Edge 1 Dir	43	Motor
26	Edge 2 Dir	46	Erase Entrapment Device

For the manual pairing of the wireless adapter

1. Use both adapters that are to be paired, installed, and powered.
2. On each adapter, press and hold the PAIR button until the LED starts blinking fast.
3. Release the PAIR button.
4. Wait several seconds and the units will be paired.

Menu Item #11 - Biparting Delay

Biparting Delay allows the users the stagger the opening of their gates. The setting will determine how long motor 2 (secondary) will delay after motor 1 (primary) starts moving in the open direction, and how long motor 1 (primary) will delay after motor 2 (secondary) starts moving in the close direction.

1. Press the SET/CLR key to enter the menu. The current value will be displayed. OFF is the default.



NOTICE

If this menu is not displayed, for dual gate applications: Make sure that "Menu 1 Gate Number" is set to 2, for primary/secondary applications: Ensure that "Menu 10 Primary/Secondary" is enabled on both operators and the setting is being configured on the Primary operator.

2. Press the UP key to set the delay in increments of 0.1 seconds. The options are OFF, 0.1 to 6.0, and Total.



- Off – Both motors will begin travel at the same time. For use when there are no ornaments or stops the restrict the movement of the gate leaves
- 0.1 – 6.0s – This is a timed delay in which motor 2 will trail motor 1 in the opening direction, and motor 1 will trail motor 2 in the closing direction. This time is adjustable in 0.1s increments.
- Total – With this option active, motor 2 will not begin its opening cycle until motor 1 has reached the open limit, and motor 1 will not begin its closing cycle until motor 2 has reached the close limit. Press and hold the key for 2 seconds for High Speed Scroll. Settings do not roll from the end back to the start; you must use the down arrow to scroll back to the beginning.

3. Press the SET/CLR key to accept the setting and exit the menu item.



Menu Item #12 - Opening & Closing Speed

1. Press the SET/CLR key to enter the menu. The current value will be displayed.
2. Press the UP key to increase the percentage of speed in increments of 5% between 30 and 100 (default is 80%). Press and hold the key for 2 seconds for High Speed Scroll.
3. Decrease the speed setting by pressing the DOWN key. It will be displayed in increments of 5% between 100 and 30. Press and hold the key for 2 seconds for High Speed Scroll. It does not wrap from 100 to 30; you must use the down arrow to get to the lower setting.
4. Press the SET/CLR key to accept the setting and exit the menu item.



NOTICE

For a second gate, set switch to gate 2 and repeat these steps.

NOTICE

For Primary/Secondary, configure both operators separately.

Menu Item #13 - Slow Down Speed

1. Press the SET/CLR key to enter the menu. The current value will be displayed.
2. Press the UP key to increase the percentage of speed in increments of 5% between 10 and 60 (default is 30%). Press and hold the key for 2 seconds for High Speed Scroll.
3. Decrease the speed setting by pressing the DOWN key. It will be displayed in increments of 5% between 60 and 10. Press and hold the key for 2 seconds for High Speed Scroll. It does not wrap from 60 to 10; you must use the down arrow to get to the lower setting.
4. Press the SET/CLR key to accept the setting and exit the menu item.



NOTICE

For a second gate, set switch to gate 2 and repeat these steps.

NOTICE

For Primary/Secondary, configure both operators separately.

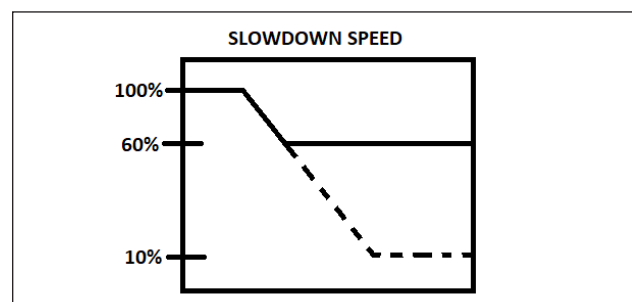

Menu Item #14 - Slow Down Space

1. Press the SET/CLR key to enter the menu. The current value will be displayed.
2. Press the UP key to increase the speed in increments of 5% between 0 and 50 (default is 25%). Press and hold the key for 2 seconds for High Speed Scroll.
3. Decrease the speed setting by pressing the DOWN key. It will be displayed in increments of 5% between 50 and 0. Press and hold the key for 2 seconds for High Speed Scroll. It does not wrap from 50 to 0; you must use the down arrow to get to the lower setting.
4. Press the SET/CLR key to accept the setting and exit the menu item.



NOTICE For a second gate, set switch to gate 2 and repeat these steps.

NOTICE For Primary/Secondary, configure both operators separately.

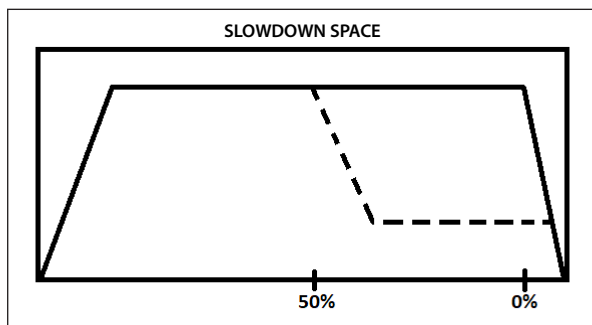

Menu Item #15 - Deceleration

1. Press the SET/CLR key to enter the menu. The current value will be displayed.
2. Press the UP key to increase the speed of deceleration in increments of 1 between 0 and 9 (default is 7). Press and hold the key for 2 seconds for High Speed Scroll.
3. Decrease the speed setting by pressing the DOWN key. It will be displayed in increments of 1 between 9 and 0. Press and hold the key for 2 seconds for High Speed Scroll. It does not wrap from 9 to 0, you must use the down arrow to get to the lower setting.
4. Press the SET/CLR key to accept the setting and exit the menu item.



NOTICE 0 is the slowest (smoothest) deceleration, 9 is the fastest.

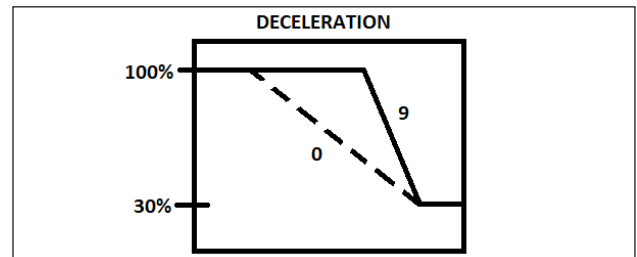

Menu Item #16 - Acceleration

1. Press the SET/CLR key to enter the menu. The current value will be displayed.
2. Press the UP key to increase the speed of acceleration in increments of 1 between 0 and 9 (default is 3). Press and hold the key for 2 seconds for High Speed Scroll.
3. Decrease the speed setting by pressing the DOWN key. It will be displayed in increments of 1 between 9 and 0. Press and hold the key for 2 seconds for High Speed Scroll. It does not wrap from 9 to 0, you must use the down arrow to get to the lower setting.



NOTICE 0 is the slowest (smoothest) acceleration, 9 is the fastest.

4. Press the SET/CLR key to accept the setting and exit the menu item.

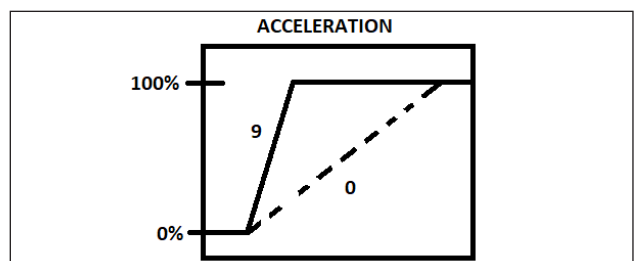

Operator Setup Procedures

6. Change the setting from OFF to PRI WIRED or PRI WLESS, depending on the setup being used, and exit the menu.

NOTICE *Menu 5 must be configured after this setting is configured.*

NOTICE *All entrapment protection devices should be wired to the primary operator.*

NOTICE *If the operator is set to secondary, menus listed below will not be available and must be configured on the primary operator logic board.*

NOTICE *If an install has 2 gates and primary/secondary mode is active and the secondary gate is not working, primary/secondary mode needs to be set to off on the primary operator in order to operate the working gate.*

Menu item #	Function	Menu item #	Function
6	Timer To Close	27	Anti-Tailgating
7	Learn New XMTR ?	28	GP1
8	Remove XMTR	29	GP2
9	Remove All XMTRs	30	COMIS
11	Bi-Parting Delay	31	Date And Time
17	24V SW	32	Daylight Savings Time
21	Photo 1 Type	33	Clock 1
22	Photo 2 Type	34	Clock 2
23	Photo 1 Dir	35	Clock 3
24	Photo 2 Dir	36	Clock 4
25	Edge 1 Dir	43	Motor
26	Edge 2 Dir	46	Erase Entrapment Device

For the manual pairing of the wireless adapter

1. Use both adapters that are to be paired, installed, and powered.
2. On each adapter, press and hold the PAIR button until the LED starts blinking fast.
3. Release the PAIR button.
4. Wait several seconds and the units will be paired.

Menu Item #11 - Biparting Delay

Biparting Delay allows the users the stagger the opening of their gates. The setting will determine how long motor 2 (secondary) will delay after motor 1 (primary) starts moving in the open direction, and how long motor 1 (primary) will delay after motor 2 (secondary) starts moving in the close direction.

1. Press the SET/CLR key to enter the menu. The current value will be displayed. OFF is the default.



NOTICE

If this menu is not displayed, for dual gate applications: Make sure that "Menu 1 Gate Number" is set to 2, for primary/secondary applications: Ensure that "Menu 10 Primary/Secondary" is enabled on both operators and the setting is being configured on the Primary operator.

2. Press the UP key to set the delay in increments of 0.1 seconds. The options are OFF, 0.1 to 6.0, and Total.



- Off – Both motors will begin travel at the same time. For use when there are no ornaments or stops the restrict the movement of the gate leaves
- 0.1 – 6.0s – This is a timed delay in which motor 2 will trail motor 1 in the opening direction, and motor 1 will trail motor 2 in the closing direction. This time is adjustable in 0.1s increments.
- Total – With this option active, motor 2 will not begin its opening cycle until motor 1 has reached the open limit, and motor 1 will not begin its closing cycle until motor 2 has reached the close limit. Press and hold the key for 2 seconds for High Speed Scroll. Settings do not roll from the end back to the start; you must use the down arrow to scroll back to the beginning.

3. Press the SET/CLR key to accept the setting and exit the menu item.



Menu Item #12 - Opening & Closing Speed

1. Press the SET/CLR key to enter the menu. The current value will be displayed.
2. Press the UP key to increase the percentage of speed in increments of 5% between 30 and 100 (default is 80%). Press and hold the key for 2 seconds for High Speed Scroll.
3. Decrease the speed setting by pressing the DOWN key. It will be displayed in increments of 5% between 100 and 30. Press and hold the key for 2 seconds for High Speed Scroll. It does not wrap from 100 to 30; you must use the down arrow to get to the lower setting.
4. Press the SET/CLR key to accept the setting and exit the menu item.



NOTICE

For a second gate, set switch to gate 2 and repeat these steps.

NOTICE

For Primary/Secondary, configure both operators separately.

Menu Item #13 - Slow Down Speed

1. Press the SET/CLR key to enter the menu. The current value will be displayed.
2. Press the UP key to increase the percentage of speed in increments of 5% between 10 and 60 (default is 30%). Press and hold the key for 2 seconds for High Speed Scroll.
3. Decrease the speed setting by pressing the DOWN key. It will be displayed in increments of 5% between 60 and 10. Press and hold the key for 2 seconds for High Speed Scroll. It does not wrap from 60 to 10; you must use the down arrow to get to the lower setting.
4. Press the SET/CLR key to accept the setting and exit the menu item.



NOTICE

For a second gate, set switch to gate 2 and repeat these steps.

NOTICE

For Primary/Secondary, configure both operators separately.

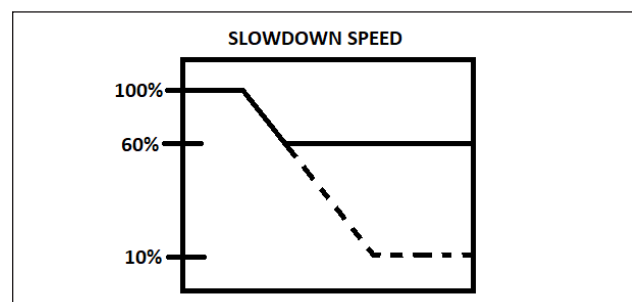

Operator Setup Procedures

Menu Item #14 - Slow Down Space

1. Press the SET/CLR key to enter the menu. The current value will be displayed.
2. Press the UP key to increase the speed in increments of 5% between 0 and 50 (default is 25%). Press and hold the key for 2 seconds for High Speed Scroll.
3. Decrease the speed setting by pressing the DOWN key. It will be displayed in increments of 5% between 50 and 0. Press and hold the key for 2 seconds for High Speed Scroll. It does not wrap from 50 to 0; you must use the down arrow to get to the lower setting.
4. Press the SET/CLR key to accept the setting and exit the menu item.



NOTICE For a second gate, set switch to gate 2 and repeat these steps.

NOTICE For Primary/Secondary, configure both operators separately.

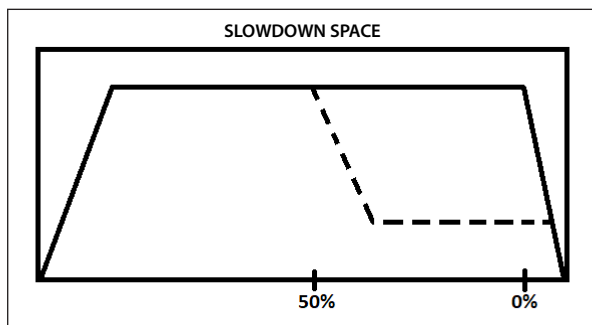

Menu Item #15 - Deceleration

1. Press the SET/CLR key to enter the menu. The current value will be displayed.
2. Press the UP key to increase the speed of deceleration in increments of 1 between 0 and 9 (default is 7). Press and hold the key for 2 seconds for High Speed Scroll.
3. Decrease the speed setting by pressing the DOWN key. It will be displayed in increments of 1 between 9 and 0. Press and hold the key for 2 seconds for High Speed Scroll. It does not wrap from 9 to 0, you must use the down arrow to get to the lower setting.
4. Press the SET/CLR key to accept the setting and exit the menu item.



NOTICE 0 is the slowest (smoothest) deceleration, 9 is the fastest.

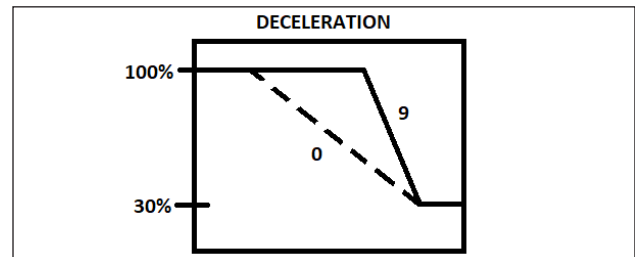

Menu Item #16 - Acceleration

1. Press the SET/CLR key to enter the menu. The current value will be displayed.
2. Press the UP key to increase the speed of acceleration in increments of 1 between 0 and 9 (default is 3). Press and hold the key for 2 seconds for High Speed Scroll.
3. Decrease the speed setting by pressing the DOWN key. It will be displayed in increments of 1 between 9 and 0. Press and hold the key for 2 seconds for High Speed Scroll. It does not wrap from 9 to 0, you must use the down arrow to get to the lower setting.
4. Press the SET/CLR key to accept the setting and exit the menu item.



NOTICE 0 is the slowest (smoothest) acceleration, 9 is the fastest.

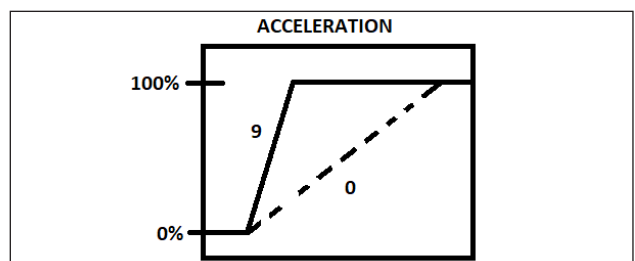

Additional Menu Items

Menu Item #17 – 24 SW

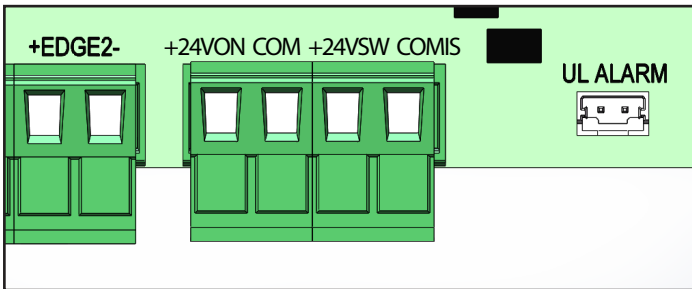

This menu will define the operating conditions for AUX devices connected to 24Vsw on the bottom of the control board. This menu does not affect the 24V pin, which is always active.

With the control board in Calibration Mode, navigate to menu item #17 using the UP/DOWN keys. Press SET/CLR to enter the menu selection. Navigate through the selections with the UP/DOWN keys. With the desired selection displayed, press the SET/CLR key to accept the selection and return to exit the menu.

- Off – AUX power is inactive.
- In Cycle – AUX power supplied only during both opening and closing cycle.
- Opening – AUX power supplied only during opening cycle.
- Closing – AUX power supplied only during closing cycle.
- In Pause – Active during timer to close countdown.
- In Cycle and Pause – Active during cycle and timer to close countdown.
- Gate Open Warning Light – Flashes a light once per second while opening, steady while open or stopped, and flashes twice per second while closing.
- Barrier and Bollard LED Lights – Light is illuminated while the gate is closed, off while the gate is open, and blinking while the operator is moving.
- Always – Aux power is always supplied.

Menu Item #18 – Emergency

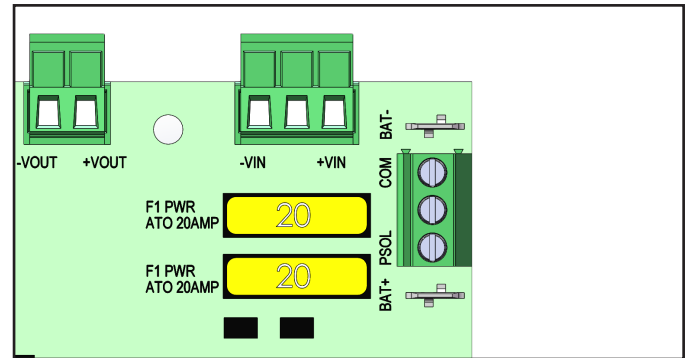

This menu item defines how a unit running on battery backup will respond when the Gate Operator loses AC power, or the battery backup system drops to a low voltage condition.

With the control board in Calibration Mode, navigate to menu item #18 using the UP/DOWN keys. Press SET/CLR to enter the menu selection. Navigate through the selections with the UP/DOWN keys. With the desired selection displayed, press the SET/CLR key to accept the selection and return to exit the menu.

- Off - Disabled
- Emergency – In case of power failure, if batteries are connected, the gate opens and remains open until power is restored.
- Battery Fail Safe – In case of power failure, as soon as the battery charge drops below 22.5V, the gate opens and remains open until the power is restored.

NOTICE The CLOSE key will not function when in this mode.

- Battery Fail Secure – In case of power failure, as soon as the battery charge drops below 22.5V, the gate closes and remains closed until power is restored.

NOTICE The OPEN key will not function when in this mode.

Operator Setup Procedures

Menu Item #19 – Relay 1

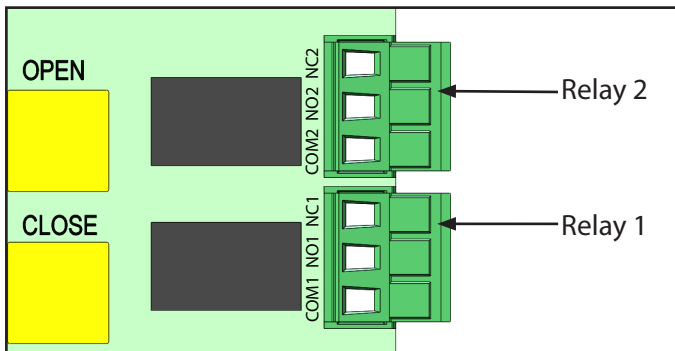

This menu item will define how an Aux device will operate when connected to the control board at RELAY 1 OUTPUT positions C, NO1 and NC1. The Aux devices can be connected in either a Normally Open (NO) or Normally Closed (NC) condition.

With the control board in Calibration Mode, navigate to menu item #19 using the UP/DOWN keys. Press SET/CLR to enter the menu selection. Navigate through the selections with the UP/DOWN keys. With the desired selection displayed, press the SET/CLR key to accept the selection and return to exit the menu.

- Off - Disabled
- Start 3S – Relay activates for 3 seconds after every command to start movement of the gate.
- Traffic Light – Relay activates when the gate is open to allow a traffic light to turn green.
- Flashing Light – Flashes a light to indicate gate is in operation.
- Courtesy Light – Turns on a light for visibility while the gate is in use.
- Fire Input – Relay activates when fire input is active.
- Limit Switch Open – Relay activates if the motor has reached the open limit status.
- Limit Switch Close – Relay activates if the motor has reached the closed limit status.
- Clock 1 & 2 – Activates and deactivates according to schedules set in clocks 1 and 2.

Menu Item #20 – Relay 2

This menu item will define how an Aux device will operate when connected to the control board at RELAY 2 OUTPUT positions C, NO2 and NC2. The Aux devices can be connected in either a Normally Open (NO) or Normally Closed (NC) condition.

With the control board in Calibration Mode, navigate to menu item #20 using the UP/DOWN keys. Press SET/CLR to enter the menu selection. Navigate through the selections with the UP/DOWN keys. With the desired selection displayed, press the SET/CLR key to accept the selection and return to exit the menu.

- Off - Disabled
- Start 3S – Relay 2 activates for 3 seconds after every command to start movement of the gate.
- Traffic Light – Relay 2 activates when the gate is open to allow a traffic light to turn green.
- Flashing Light – Relay 2 Flashes a light to indicate gate is in operation.
- Courtesy Light – Relay 2 Turns on a light for visibility while the gate is in use.
- Fire Input – Relay 2 activates when the fire input is active.
- Limit Switch Open – Relay 2 activates if the motor has reached the open limit status .
- Limit Switch Close – Relay 2 activates if the motor has reached the closed limit status.
- Clock 3 & 4 – Activates and deactivates according to schedules set in clocks 3 and 4 (see page 41 to set up clock 3 & 4).

Menu Item #21 – Photo 1 Type

- STB – 2 Wire Pulsed – 2 wire pulsed type photoeye.
- 10k – 10k ohm monitored photoeye.

Menu Item #22 – Photo 2 Type

- STB – 2 Wire Pulsed – 2 wire pulsed type photoeye.
- 10k – 10k ohm monitored photoeye.

Menu Item #23 – Photo 1 Direction

- Closing – Obstructing the eye will only reverse the gate when it is traveling in the closing direction; gate reverses to the full open position.
- Closing and Opening – Obstructing the eye will reverse the gate when traveling in the opening or closing direction. When closing, the gate reverses full open; when opening, the gate reverses for two seconds.

Menu Item #24 – Photo 2 Direction

- Opening – Obstructing the eye will only reverse the gate when it is traveling in the opening direction; gate reverses travel for two seconds.
- Opening and Closing – obstructing the eye will reverse the gate when traveling in the opening or closing direction. When closing, the gate reverses full open; when opening, the gate reverses for two seconds.

Menu Item #25 – Edge 1 – Dir

- Closing – Activation of the edge sensor will only reverse the gate when it is traveling in the closing direction; gate reverses travel to the full open position.
- Closing and Opening – Activation of the edge sensor will reverse the gate when traveling in the opening or closing direction. When closing, the gate reverses full open; when opening, the gate reverses for two seconds.

Menu Item #26 – Edge 2 – Dir

- Opening – activation of the edge sensor will only reverse the gate when it is traveling in the opening direction; gate reverses travel to the full open position.
- Opening and Closing – Activation of the edge sensor will reverse the gate when traveling in the opening or closing direction. When closing, the gate reverses full open; when opening, the gate reverses for two seconds.

Menu Item #27 – Anti Tailgating

Enables a quick close function that closes the gate after a car clears the opening.

- Off - Default
- On – Enables use of the reversing loop for tailgate detection.

Menu Item #28 – GP1

Configures operator response to any device wired into the GP1 input.

- Off - Default
- Latch Open – Allows for connection of a normally open switch to latch the gate open.
- Sally PortM1 – Enables operation of motor 1 when motor 2 is closed and disables motor 1 if motor 2 is not closed.

Menu Item #29 – GP2

Configures operator response to any device wired into the GP2 input.

- Off - Default
- Latch Close – Allows for connection of a normally open switch to latch the gate closed.
- Sally PortM2 – Enables operation of motor 2 when motor 1 is closed, and disables motor 2 if motor 1 is not closed.

Menu Item #30 – COMIS

Displays the current draw of accessories that are powered from 24V ON or 24V SW and grounded on the COMIS terminal.

- 0-800

Menu Item #31 – Date and Time

Configures the real-time date and time that will be referenced by the clock menus.

- MM/DD/YY
- Sun – Sat
- hh:mm AM/PM

Menu Item #32 – Daylight Savings Time

Automatically adjusts for daylight savings time when enabled.

- On – Default
- Off – Daylight savings inactive

Operator Setup Procedures

Menu Items #33-36 – Clock 1-4

Configures scheduled opening and closing times for the gate.

- Opening Time – hh:mm AM/PM
- Closing Time – hh:mm AM/PM
- Mon – Sun – On/Off
- End – Exits menu

Menu Item #37 – Password

User configurable four-digit password. Number is selected with the UP/DOWN keys; SET/CLR locks in the number and advances to the next digit.

Menu Item #38 – Diagnostics

Displays the 10 most recent errors detected. Ordered from 1 being the most recent, to 10 being the oldest. Errors can be scrolled through using the UP/DOWN keys.

Menu Item #39 – Maintenance Cycles

Allows configuration of the number of cycles that can be performed before the maintenance alarm sounds.

Menu Item #40 – Performed Cycles

Displays the total number of cycles performed during the life of the operator.

Menu Item #41 – Working Current

Displays the real-time current draw of the operator in amps.

- X.X

Menu Item #43 – Motor

Allows selection of the motor that corresponds to the operator that the logic board is installed in.

- 1 – 24V LINEAR ACTUATOR
- 2 – 24V CHAIN SLIDE
- 3 – 24V SWING PAD MNT
- 4 – 36V CHAIN SLIDE
- 5 – 36V SWING PAD MNT

Menu Item #44 – Language

Configures the system language.

- English
- Francais
- Espanol

Menu Item #45 – Factory Reset

Returns operator to factory parameters (motor selection and photo eye type will be retained). The user will be prompted to hold the UP key, which will trigger a 5 second countdown. Once the countdown completes RESET OK will be displayed. The operator will then display IDLE NO LIMIT and can be reprogrammed.

Menu Item #46 – Erase Entrapment Device

Erases all learned entrapment devices. User will be prompted to hold the UP key which will initiate a 5 second countdown. When the countdown completes, all learned entrapment devices will be unlearned. Any entrapments that are still installed to the operator will then relearn from the automatic learning cycle performed by the operator.

Menu Item #47 – Firmware Version

Displays the version of firmware that is running on the operator.

- VXX.XX

Menu Item #48 – Battery Backup Voltage

Displays the real-time voltage of the two sealed lead acid batteries in the operator used for battery backup.

NOTICE *The AC power switch must be turned off, and the battery switch must be on, in order to see the battery voltage.*

Operator Alarm



The alarm is very loud.
Failure to use hearing protection could result in minor or moderate injury.

The alarm will sound if a contact sensor detects an obstruction twice in a row, without traveling to the open or closed limit. It will sound up to 5 minutes. The operator will need to be reset (see below).

If any of the following conditions are met, the alarm will sound:

- The operator or gate is not installed correctly.
- The gate does not meet specifications.
- The gate hinges do not allow the gate to move freely.
- A car pushes the gate while it is moving.
- An object is on the gate frame while the gate is moving.
- The gate hits the curb or driveway, and is bent or stuck in the wrong position.

After removing any obstructions, press the reset button (see below) to turn off the alarm and reset the operator. Normal functions will resume.

Reset Button

The reset button is located on the right side of the control box. It is used to:

- Stop the gate from moving during an open/close cycle.
- Disable the Timer-to-close when the gate is in the open position. (Timer will be re-enabled the next time the gate reaches the open limit.)
- Shut off the alarm and reset the operator.



Remote Control

Single Button Wired Control Station or Single Button Wireless Control Device

When the gate is in the closed position, pressing the remote button will cause the gate to move toward the open position.

While the gate is opening, pressing the remote button will stop the gate, and it will remain in that position.

The next button press will cause the gate to move toward the closed position.

Pressing the button while the gate is moving in the close direction will stop the gate, and it will remain in that position.

The next button press will cause the gate to move in the open direction.

This cycle repeats indefinitely.

Solar Operation

Solar Powered Operation

This section will help the installer select the correct panel wattage, the type of charge controller required and the appropriate battery capacity, based on the required number of daily gate cycles. There are several accessory kits available to put together an optimal solar operation for each gate. Utilize the solar cycle table below to determine which option is best.

Solar Irradiance Map of North America (With Zones and Cities Added)

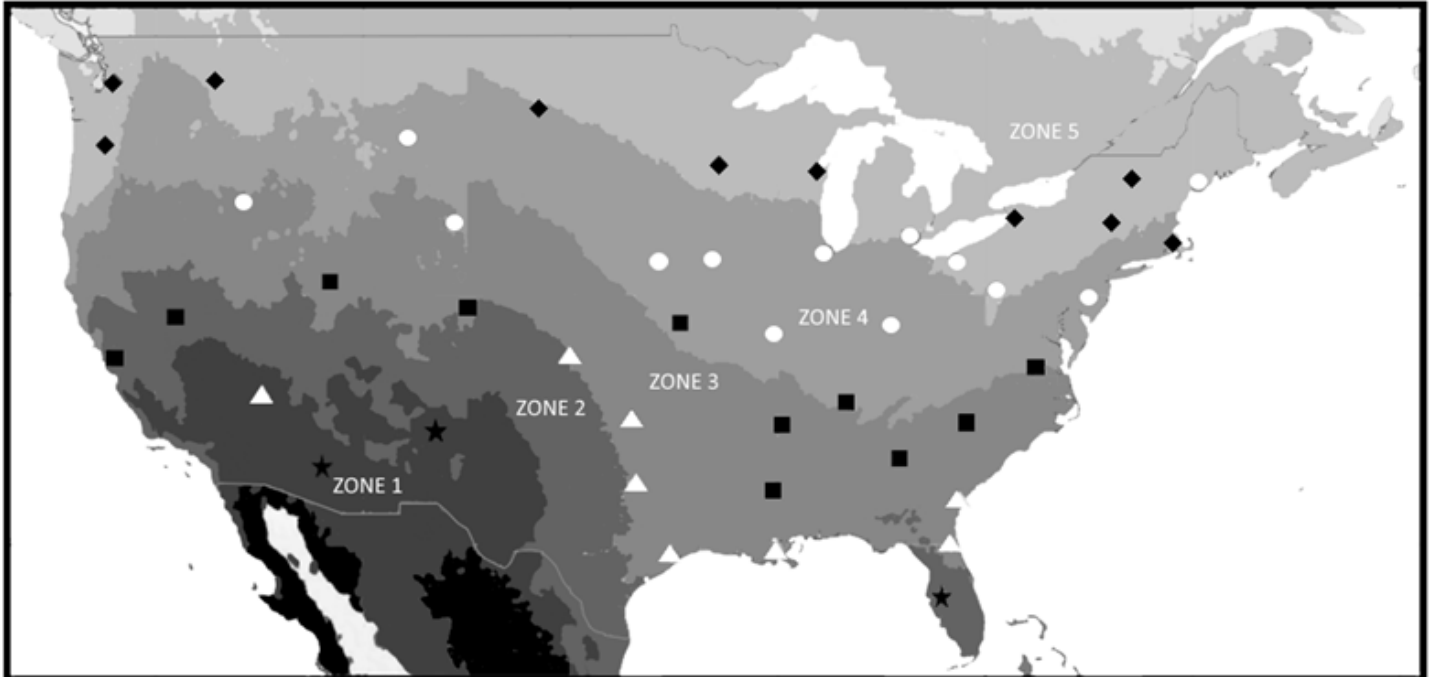

ZONE 1 ★	ZONE 2 ▲	ZONE 3 ■	ZONE 4 ●	ZONE 5 ◆
Phoenix, AZ Albuquerque, NM Tampa, FL	Las Vegas, NV Dallas, TX New Orleans, LA Jacksonville, FL Savannah, GA Oklahoma City, OK Dodge City, KS Houston, TX	San Francisco, CA Jackson, MS Salt Lake City, UT Denver, CO Charlotte, NC Atlanta, GA Reno, NV Memphis, TN Richmond, VA Kansas City, MO Nashville, TN	Casper, WY Cincinnati, OH Boise, ID Billings, MT Portland, ME Philadelphia, PA St Louis, MO Cleveland, OH Chicago, IL Detroit, MI Pittsburgh, PA Omaha, NE Des Moines, IA	Bismarck, ND Green Bay, WI Minneapolis, MN Portland, OR Buffalo, NY Seattle, WA Albany, NY Burlington, VT Spokane, WA Boston, MA

This map was produced by the National Renewable Energy Laboratory for the US Department of Energy
Billy J. Roberts, February 22nd, 2018



	Single Gate - Cycles per Day									
	Zone 1		Zone 2		Zone 3		Zone 4		Zone 5	
	7AH	35AH	7AH	35AH	7AH	35AH	7AH	35AH	7AH	35AH
20W w/onboard charger	12	-	0	-	0	-	0	-	0	-
50W w/external PWM charger	168	204	132	156	84	108	30	60	0	0
90W w/external PWM charger	204	432	204	336	192	288	132	168	36	48

This table is based on the average daily solar insolation for the lowest month of the year. It is an estimate, and the actual number of daily cycles will depend on installed accessories, size of the gate and the actual solar insolation realized.

Table is theoretical based on system/battery capacity. Operator Specifications of daily limits still apply.

7Ah 12V Batteries (Qty 2 included with each operator):

- Option 1 (20 Watt) – Utilize the on-board charge controller by addition of the optional 20 Watt 24V solar panel kit (113409.0001.S) – includes 20W 24V solar panel & solar panel mounting bracket
- Option 2 (50 Watt) – Utilize the optional 50 Watt 24V solar panel kit (113455.0001.S) – includes external charge controller, 50W 24V solar panel & solar panel mounting bracket.
- Option 3 (90 Watt) – Utilize the optional 90 Watt 24V solar panel kit (113456.0001.S) – includes external charge controller, 90W 24V solar panel & solar panel mounting bracket

35Ah 12V Batteries (Optional) (113381.0001.S - Qty 2 required):

- Option 4 (50 Watt) - Utilize the optional 50 Watt 24V solar panel kit (113455.0001.S) – includes external charge controller, 50W 24V solar panel & solar panel mounting bracket
- Option 5 (90 Watt) – Utilize the optional 90 Watt 24V solar panel kit (113456.0001.S) – includes external charge controller, 90W 24V solar panel & solar panel mounting bracket

Additional Solar Accessories Available:

- 113478.0001.S - Solar Wiring Harness Kit – (works with all 7AH & 35AH battery configurations)
- 113470.0001.S - Charge Controller Mounting Bracket Kit for Linear Actuator Enclosure - (works with all 7AH & 35AH battery configurations)
- 113475.0001.S - 35AH Battery Box Kit for Linear Actuator Operators - (works with all 35AH battery configurations)

Installation on Mount Brackets (Included with optional Solar Panel Kits)

20 Watt and 50 Watt Bracket, Pole and Wall Mountable

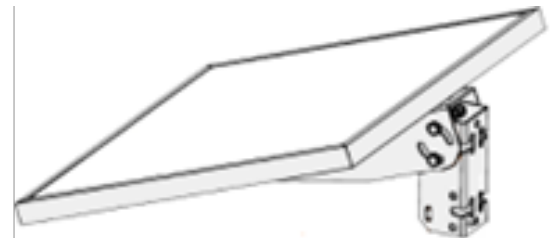
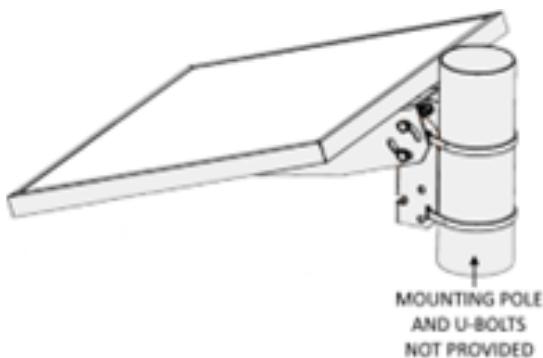

90 Watt Bracket, Pole and Wall Mountable

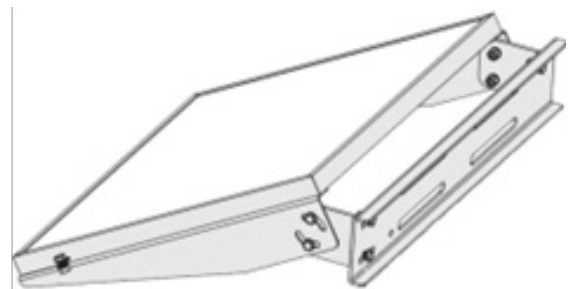
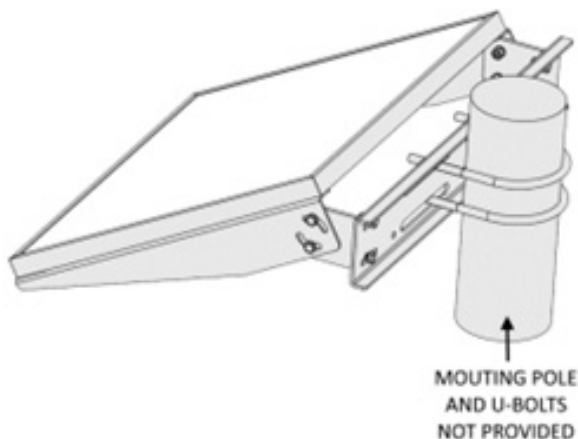

Solar Operation

Solar Panel Alignment and Tilt Angle

In order to optimize the amount of solar irradiance, solar panels must be aligned facing True South and have a Tilt Angle (relative to the horizontal ground). The Tilt Angle will vary with location, depending on where the panels are being installed geographically. Refer to the map below in order to adjust the panel installation to optimized alignment of True South and appropriate Tilt Angle.





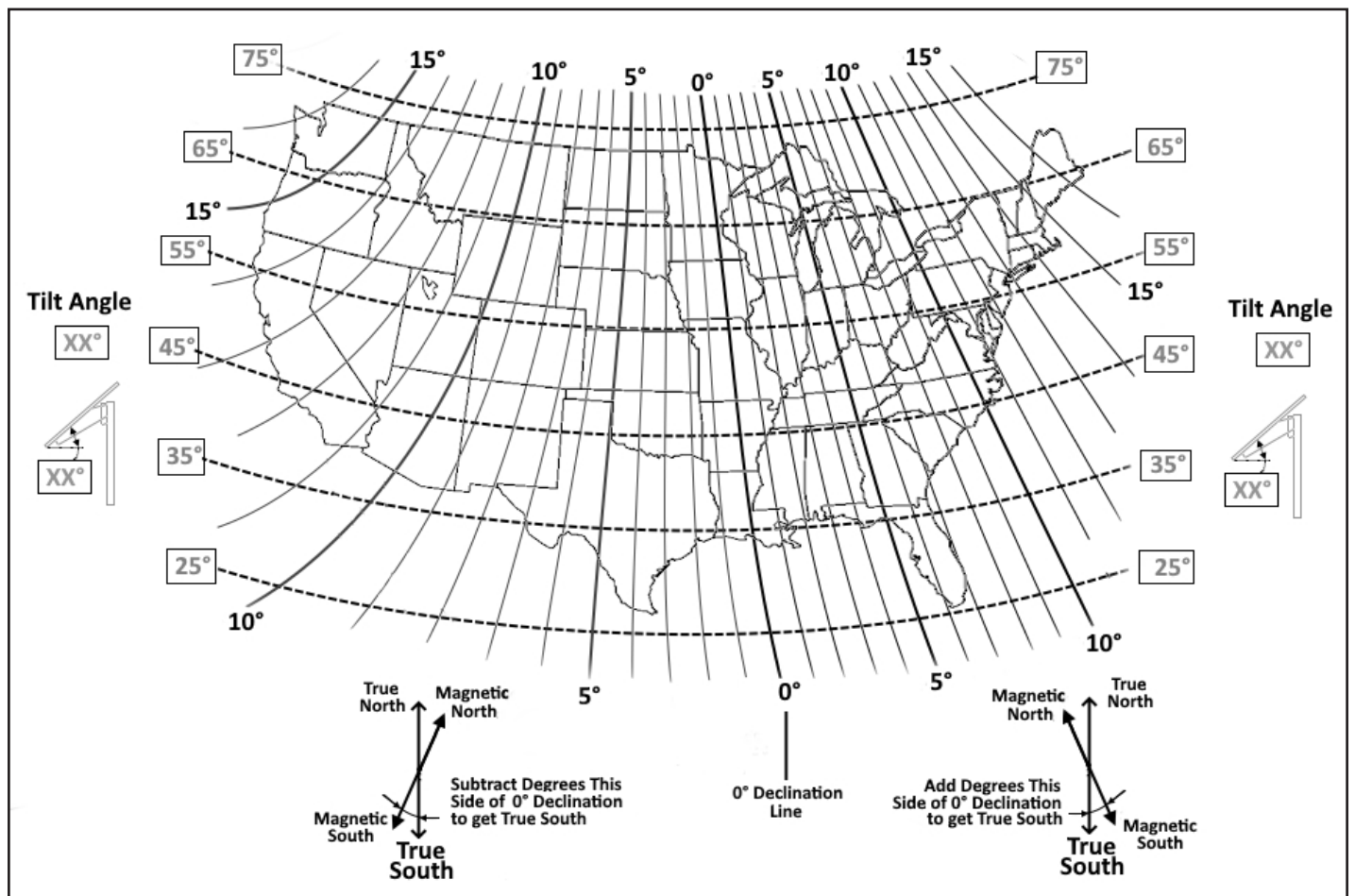

Additional concerns that must be considered and avoided in solar panel installation:

- Avoid any shading of the panels by buildings, tree cover, etc.
- Solar panels should be installed as near to the operator as possible.
- Consider the local environment the solar panel is being installed in and make sure to accommodate secure mounting in a position optimized to avoid issues with strong winds, snow, and soiling due to settling dust.

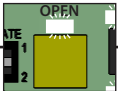

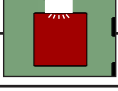
THIS PAGE LEFT BLANK

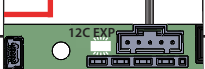
Troubleshooting

Control Board LEDs			
Status LEDs			
OPEN KEY	On	The open key is active	
	Off	The open key is inactive	
CLOSE KEY	On	The close key is active	
	Off	The close key is inactive	
STOP KEY	On	The stop key is active	
	Off	The stop key is inactive	
UL RESET	On	The UL Reset button is active or circuit is broken	
	Off	The UL Reset button is inactive	
WIRELESS PRI/SEC	On	Wireless primary/secondary communication established	
	Off	Wireless primary/secondary is inactive	
I2C EXP	On	I2C communication has been established	
	Off	I2C bus is inactive	
Battery	On	The battery polarity is reversed and must be corrected	
	Off	Batteries are connected properly	

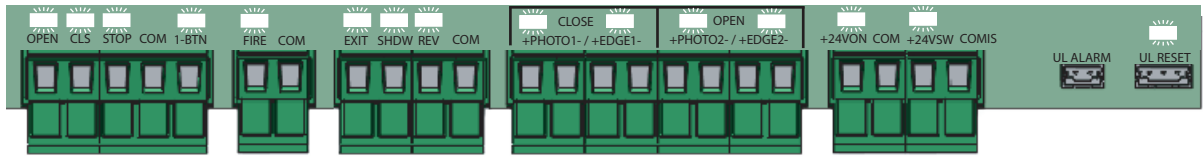

Input LEDs

OPEN	On	Open input is active	
	Off	Open input is inactive	
CLOSE	On	Close input is active	
	Off	Close input is inactive	
STOP	On	Stop input is active	
	Off	Stop input is inactive	
1BTN	On	1-Button input is active	
	Off	1-Button input is inactive	
FIRE	On	Fire input is active	
	Off	Fire input is inactive	
EXIT	On	Exit loop is active	
	Off	Exit loop is inactive	
SHDW	On	Shadow loop is active	
	Off	Shadow loop is inactive	
REV	On	Reversing loop is active	
	Off	Reversing loop is inactive	
PHOTO 1	On	Photo 1 is inactive or obstructed	
	Off	Photo 1 is active	
	Blinking	Minimum required entrapment devices not met	
EDGE 1	On	Edge 1 is inactive or actuated	
	Off	Edge 1 is active	
	Blinking	Minimum required entrapment devices not met	
PHOTO 2	On	Photo 2 is inactive or obstructed	
	Off	Photo 2 is active	
	Blinking	Minimum required entrapment devices not met	
EDGE 2	On	Edge 2 is inactive or actuated	
	Off	Edge 2 is active	
	Blinking	Minimum required entrapment devices not met	
+24V SW	On	24V auxiliary power is active	
	Off	24V auxiliary power is inactive	
GP1	On	GP1 is active	
	Off	GP1 is inactive	
GP2	On	GP2 is active	
	Off	GP2 is inactive	
RELAY1	On	Relay 1 is active	
	Off	Relay 1 is inactive	
RELAY2	On	Relay 2 is active	
	Off	Relay 2 is inactive	

Troubleshooting

Troubleshooting		
Problem	Potential Cause	Solution
Operator won't cycle and logic board display won't illuminate	<ol style="list-style-type: none"> 1. Logic board is not receiving power 2. Blown fuse 3. Low batteries 4. Defective logic board 	<ol style="list-style-type: none"> 1. Check power wiring, if on wall power ensure that the switching power supply is functioning. 2. Check fuses and replace if necessary. 3. Use AC or solar to charge batteries, replace if defective. 4. Replace defective logic board.
Logic board has power but the motor will not run.	<ol style="list-style-type: none"> 1. Stop is active 2. Low batteries 3. Entrapment protection device active or defective 4. Loop detector active 5. Motor not receiving power 6. Faulty connection between logic board and drive board 7. Drive board is not receiving power 8. Defective logic board or drive board 	<ol style="list-style-type: none"> 1. Ensure that stop circuit is closed and UL Reset header is plugged in. 2. Use AC or solar to charge batteries, replace if defective 3. Ensure eyes are unobstructed and edges are not depressed. Ensure devices have power and edge resistance measures to spec. Replace if necessary. 4. Ensure loops are clear and working properly, replace detector if defective. 5. Check voltage output of drive board and continuity of motor wire. Replace if defective. 6. Check for proper seating of serial cable between logic and drive boards. 7. Check power wiring from logic board to drive board. 8. Replace defective board(s).
Operator moves but the limits cannot be set	<ol style="list-style-type: none"> 1. Incorrect motor direction 2. Movement of gate is impeded 	<ol style="list-style-type: none"> 1. Check that the gate travels in the closing direction when the close key is pressed, correct if necessary. 2. Ensure that the gate moves freely and is not blocked; repair if needed.
Gate does not reach fully open or close position while learning limits.	<ol style="list-style-type: none"> 1. Encoder over range 2. Movement of the gate is impeded 3. Gate is too hard to move 	<ol style="list-style-type: none"> 1. Detach encoder chain and adjust it to a new position. 2. Check that nothing is blocking the gate from moving. 3. Remove the Operator from the gate and ensure smooth operation of the gate for the entirety of the open and close, and make repairs if needed. <p>If the gate moves freely, increase the reversing force on the operator.</p>
Operator is not responding to wired input commands (open, close, 1btn)	<ol style="list-style-type: none"> 1. Inputs are sticking 2. Inputs are wired incorrectly 3. Stop is active 4. Low batteries 5. Entrapment protection device active 6. Loop detector active 	<ol style="list-style-type: none"> 1. If one of the input LEDs stays lit the device is sticking. Repair or replace input device. 2. Ensure that input is wired into the appropriate terminal. 3. Ensure that stop circuit is closed and UL Reset header is plugged in. 4. Use AC or solar to charge batteries, replace if defective. 5. Ensure eyes are unobstructed and edges are not depressed. Ensure devices have power and edge resistance measures to spec. Replace if necessary. 6. Ensure loops are clear and working properly; replace detector if defective.
Operator is not responding to inputs from a wireless transmitter	<ol style="list-style-type: none"> 1. Battery is dead or transmitter is unpaired 2. Poor radio reception 3. Stop is active 4. Low batteries 5. Entrapment protection device active 6. Loop detector active 	<ol style="list-style-type: none"> 1. Test other transmitter. If it works, check pairing and battery of non working transmitter. 2. Test to see if comparable wired controls work properly. Test to see if the transmitter works while close to the operator; check radio antenna; test any other wireless controls for similar issues. 3. Ensure that stop circuit is closed and UL Reset header is plugged in. 4. Use AC or solar to charge batteries; replace if defective. 5. Ensure eyes are unobstructed and edges are not depressed. Ensure devices have power and edge resistance measures to spec. Replace if necessary. 6. Ensure loops are clear and working properly; replace detector if defective.
Operator stops and reverses during travel	<ol style="list-style-type: none"> 1. Entrapment protection device is active 2. Loop detector is active 3. Low Batteries 4. Gate is too hard to move 	<ol style="list-style-type: none"> 1. Ensure that the travel of the gate is not activating any of the entrapment protection devices. 2. Ensure that the loops are properly spaced and not being activated by the gate movement. 3. Ensure that the battery voltage is above the 22.2VDC. 4. Remove the Operator from the gate and ensure smooth operation of the gate for the entirety of the open and close, and make repairs if needed. <p>If the gate moves freely, increase the reversing force on the operator.</p>

Troubleshooting (Continued)		
Problem	Potential Cause	Solution
Neither transmitter nor timer to close will close gate after opening	<ol style="list-style-type: none"> 1. Open control is active 2. Loop detector is active 3. Entrapment protection device is active 4. Fire department input is active 5. Low Batteries 	<ol style="list-style-type: none"> 1. Check if any opening controls are latched to keep the gate open. 2. Check that the loops are clear of any metals including the gate. 3. Check photoeyes for obstructions, and edges for contact or breaks in continuity. 4. Check fire department input. 5. Ensure that the batteries are above 22.2VDC. Recharge with AC or solar if necessary.
Operator closes but will not open	<ol style="list-style-type: none"> 1. Open entrapment active 2. Low batteries (fail secure) 	<ol style="list-style-type: none"> 1. Check photoeyes for obstructions, and edges for contact or breaks in continuity. 2. Ensure that the batteries are above 22.2VDC. Recharge with AC or solar if necessary.
Exit loop does not trigger an opening cycle	<ol style="list-style-type: none"> 1. Loop detector not configured correctly 2. Defective loop detector 3. Defective loop 4. Low batteries 	<ol style="list-style-type: none"> 1. Review configuration of loop detector; consult manual if necessary. 2. Replace loop detector. 3. Have a technician test the continuity of the loop; replace if necessary. 4. Ensure batteries are above 22.2VDC. Recharge with AC or solar if necessary.
Reversing loop does not trigger reversal of the operator	<ol style="list-style-type: none"> 1. Loop detector not configured correctly 2. Defective loop detector 3. Defective loop 	<ol style="list-style-type: none"> 1. Review configuration of loop detector; consult manual if necessary. 2. Replace loop detector. 3. Have a technician test the continuity of the loop; replace if necessary.
Shadow loop does not stop the Operator from closing	<ol style="list-style-type: none"> 1. Loop detector not configured correctly 2. Defective loop detector 3. Defective loop 	<ol style="list-style-type: none"> 1. Review configuration of loop detector; consult manual if necessary. 2. Replace loop detector. 3. Have a technician test the continuity of the loop; replace if necessary.
Operator does not reverse on obstruction	<ol style="list-style-type: none"> 1. Reversing force adjustment needed 	<ol style="list-style-type: none"> 1. Follow the procedure on page 32 for adjustment of the force.
Photoeye does not reverse the Operator	<ol style="list-style-type: none"> 1. Incorrect wiring 2. Incorrect configuration 3. Defective photoeye 	<ol style="list-style-type: none"> 1. Ensure photoeye is wired correctly per instructions. 2. Ensure that photoeye type matches the type of eye being used (menu 21-22) and the input being used is programmed for the direction being tested (menu 23-24). 3. Replace defective photoeye, retest with new eye, and ensure operator stops and reverses.
Sensing edge does not reverse the Operator	<ol style="list-style-type: none"> 1. Incorrect wiring 2. Incorrect configuration 3. Defective edge 	<ol style="list-style-type: none"> 1. Ensure the edge is wired correctly per instructions. 2. Ensure the proper direction is assigned to the input being used (menu 25-26). 3. Replace defective edge, retest with new sensor, and ensure the operator stops and reverses.
Alarm sounds for 5 minutes	<ol style="list-style-type: none"> 1. Double obstruction has occurred 	<ol style="list-style-type: none"> 1. Check for obstructions in the path of the gate. If none are found, remove operator and check for free movement of the gate; make repairs if necessary.
Incorrect gate opens first on biparting installation	<ol style="list-style-type: none"> 1. Improper motor wiring 2. Improper primary/secondary configuration 	<ol style="list-style-type: none"> 1. If running two Operators from a single control box, ensure the operator that should open first is wired into the motor 1 terminals, and the operator that should open second is wired into the motor 2 terminals. 2. If running two Operators in primary/secondary, ensure the operator that should open first is configured as primary (menu 10), and the operator that should open second is configured as secondary.
Alarm beeps when running	<ol style="list-style-type: none"> 1. Maintenance is needed 	<ol style="list-style-type: none"> 1. Have the operator serviced and reset the maintenance counter.
24V SW remains on	<ol style="list-style-type: none"> 1. Incorrect configuration of 24V SW 	<ol style="list-style-type: none"> 1. Ensure that 24V SW is not set to always (menu 17).

Troubleshooting

Troubleshooting (Continued)		
Problem	Potential Cause	Solution
Accessories connected to 24V SW turning off or resetting	1. Normal behavior	2. move accessories to 24VON or reconfigure 24V SW to always (menu 17).
Accessories connected to 24VON resetting and powering down	1. Accessory current limit exceeded 2. Defective logic board	1 Calculate current draw of accessories, or move ground to COMIS and check the total current draw (menu 30). 2. Replace defective logic board.
Anti-tailgating not working	1. Anti tailgating setting not set 2. Defective loop module 3. Defective loop	1. Check the antitailgating is set (Menu 27). 2. Test loop detector module; replace if defective. 3. Test loop wire; replace if defective.
Relay not working	1. Relay setting incorrectly configured 2. Wiring to relay is incorrect 3. Defective logic board	1. Ensure proper configuration of the realy logic (menu 19-20). 2. Ensure accessories are wired either NO to COM or NC to COM. 3. Replace defective logic board.
Solar not yielding necessary cycles per day	1. Panel wattage too low 2. High power draw from accessories 3. Aged batteries 4. Insufficient sunlight exposure for panels	1. Add more panels or replace current panel with a higher wattage panel. 2. Reduce quantity of accessories or replace with more efficient alternatives. 3. Replace the batteries. 4. Relocate panels to a more open area.
Solar does not provide enough standby time	1. Panel wattage too low 2. High power draw from accessories 3. Aged batteries 4. Insufficient sunlight exposure for panels 5. Battery capacity too low	1. Add more panels or replace current panel with a higher wattage panel. 2. Reduce quantity of accessories or replace with more efficient alternatives. 3. Replace the batteries. 4. Relocate panels to a more open area. 5. Replace with high AH rated batteries.

Logic Board Errors		
Error	Problem	Solution
No Net	No net current flow from power supply	1. Check wiring and switches to ensure no break in continuity 2. Replace defective power supply
24V	24V auxiliary power failure	1. Check that the current limit of the 24V supply has not been exceeded.
COMIS	Maximum current supply exceeded	1. Reduce number of accessories, or switch to more efficient alternatives
Blocked Motor 1	Motor 1 is blocked	1. Check for obstructions in the gate's path 2. Disconnect operator and ensure gate travels smoothly; repair if necessary
Encoder RT 1 - Rs485	System could not establish communication with encoder	1. Check wiring and seating of encoder cable 2. Replace defective encoder
Failure Edge 1	Edge 1 is not detected	1. Check wiring and resistance of the edge; replace if defective
Failure Edge 2	Edge 2 is not detected	1. Check wiring and resistance of the edge; replace if defective
Photo 1	Photo 1 is obstructed or not detected	1. Check for obstructions to the photo beam 2. Check wiring to ensure eye is properly installed 3. Check photo type menu for proper configuration 4. Replace defective photo eye
Photo 2	Photo 2 is obstructed or not detected	1. Check for obstructions to the photo beam 2. Check wiring to ensure eye is properly installed 3. Check photo type menu for proper configuration 4. Replace defective photo eye
Battery	Battery voltage too low	1. Recharge batteries 2. Replace defective batteries
Serial 1	Serial connection issue with drive board	1. Check USB connection to drive board 2. Check power wiring to drive board 3. Replace defective drive board
Serial 1 from Module 1	Logic board lost power but drive board remained powered	1. Check wiring for logic board and driver board. 2. Replace defective logice board.
Power Module 1	1. Serial fault 2. Overcurrent Motor 1	1. Inspect USB connection 2. Ensure that motor 1 is unobstructed and gate moves freely
Length Over Range 1	Operator has travelled beyond its set limit	1. Manually release and move to mid point and re-engage 2. Reset open and close limits 3. Replace defective limit encoder
Password	Password needed for further action	1. Input Password
Secondary Serial	Serial connection issue with drive board on secondary operator	1. Check USB connection to drive board 2. Check power wiring to drive board 3. Replace defective drive board
Secondary	Wired communication with secondary operator not established	1. Check for proper wiring of the primary/secondary connection 2. Check that primary/secondary setting is correct (menu 10)

Troubleshooting

Diagnostic Menu Error Messages		
Error	Problem	Solution
Photo Closing	Photo eye was obstructed in the closing direction	1. Ensure that the gate is not obstructing the photo beam. 2. Replace defective photo eye.
Photo Opening	Photo eye was obstructed in the opening direction	1. Ensure that the gate is not obstructing the photo beam. 2. Replace defective photo eye.
Obstacle in Opening M1	Motor 1 was obstructed in the opening direction causing reversal	1. Check for obstacles that would obstruct motor 1 in the opening direction. 2. Ensure that the gate moves freely; repair if necessary. 3. Increase reversing force to overcome heavy gate.
Obstacle in Closing M1	Motor 1 was obstructed in the closing direction causing reversal	1. Check for obstacles that would obstruct motor 1 in the closing direction. 2. Ensure that the gate moves freely, repair if necessary. 3. Increase reversing force to overcome heavy gate.
Edge	An edge sensor was activated causing reversal of the gate	1. Check for obstructions that would contact the sensing edge during operation. 2. Replace defective edge.
Failure Edge 1	Edge 1 is no longer detected	1. Check proper wiring of sensing edge. 2. Check resistance of edge; replace if defective.
Failure Edge 2	Edge 2 is no longer detected	1. Check proper wiring of sensing edge. 2. Check resistance of edge; replace if defective.
Stop	Stop input is active	1. Ensure no stop input is latched closed. 2. Ensure there is no break in continuity in the stop circuit.
Maintenance	Maintenance is required	1. Perform scheduled maintenance.
Battery	Battery voltage dropped below minimum threshold	1. Recharge batteries using AC or solar. 2. If solar installation, increase panel wattage or battery capacity. 3. Replace defective batteries.
No Net	Net current flow from AC reduced to zero	1. Ensure there have been no recent power outages. 2. Check wiring to power supply. 3. Replace defective power supply.
Limit Switch	Limit switch failure or overrun	1. Check that the operator has not travelled past the limits. 2. Check the limit switch wiring. 3. Replace defective switches.
Emergency	The emergency input was triggered	1. Ensure that emergency input is properly deactivated if it has been used. 2. Check wiring to emergency input.
Power Module 1	Power module 1 failed	1. Ensure that serial connection and power to drive board is good. 2. Ensure that the operator and gate move freely. 3. Replace defective drive board.
From Module 1	Logic board lost power but drive board remained powered	1. Check wiring for logic board and driver board. 2. Replace defective logic board.
COMIS	COMIS max current exceeded	1. Check the current consumption of accessories, reduce accessories, or replace with more efficient alternatives.
Photo 1	Photo 1 is not detected	1. Ensure photo eye is unobstructed. 2. Check wiring of photo eye. 3. Replace defective photo eye.
Photo 2	Photo 2 is not detected	1. Ensure photo eye is unobstructed. 2. Check wiring of photo eye. 3. Replace defective photo eye.



Gate Operator Limited Warranty

The authorized dealer of Genie® brand products whose name appears below ("Seller") warrants to the original purchaser of the GCSW36V commercial swing gate operator ("Product"), subject to all of the terms and conditions hereof, that the product and all components thereof will be free from defects in materials and workmanship under normal use for the following period(s), measured from the date of installation.

- Five (5) years

Seller's obligation under this warranty is specifically limited to repairing or replacing, at its option, any part which is determined by Seller to be defective during the applicable warranty period. Any labor charges are excluded and will be the responsibility of the purchaser.

This warranty is made to the original purchaser of the Product only, and is not transferable or assignable.

This warranty does not apply to any unauthorized alteration or repair of the Product, or to any Product or component which has been damaged or deteriorated due to misuse, neglect, accident, failure to provide necessary maintenance, normal wear and tear, or acts of God or any other cause beyond the reasonable control of Seller.

THIS WARRANTY IS EXCLUSIVE AND IN LIEU OF ANY OTHER WARRANTIES, EITHER EXPRESSED OR IMPLIED, INCLUDING BUT NOT LIMITED TO ANY IMPLIED WARRANTY OF MERCHANTABILITY OR FITNESS FOR A PARTICULAR PURPOSE.

IN NO EVENT SHALL SELLER BE RESPONSIBLE FOR, OR LIABLE TO ANYONE FOR, SPECIAL, INDIRECT, COLLATERAL, PUNITIVE, INCIDENTAL OR CONSEQUENTIAL DAMAGES, even if Seller has been advised of the possibility of such damages. Such excluded damages include, but are not limited to, loss of goodwill, loss of profits, loss of use, cost of any substitute product, interruption of business, or other similar indirect financial loss.

Claims under this warranty must be made promptly after discovery, within the applicable warranty period, and in writing to the Seller or to the authorized dealer or installer whose name and address appear below.

The Genie Company will only accept returned materials that are in warranty. Products being returned must be accompanied by a Return Authorization (RA) Tag. To obtain a Return Authorization Tag please use the following guidelines.

- Complete Products will not be replaced without prior approval from The Genie Company.
- To return a Product part during the warranty period, the Seller must contact the Technical Service Group at 1-800-843-4084. The following information is required: Operator Model Number, Serial Number, Date Code, and a description of the malfunction. The Technical Service Group will issue, via mail, an RA Tag for the part.
- Upon receipt of the part, The Genie Company will evaluate the part for a defect in material and/or workmanship. If it is determined there is a defect, the Seller will be credited the cost of the part. If it is determined there is not a defect in material and/or workmanship, no credit will be issued.

MODEL # _____
SERIAL # _____
DATE CODE # _____
ORIGINAL PURCHASER _____
INSTALLATION ADDRESS _____
DATE OF INSTALLATION _____
SELLER _____
SIGNATURE OF SELLER _____