

DC Vehicular BARRIER ARM GATE OPERATOR

INSTALLATION MANUAL

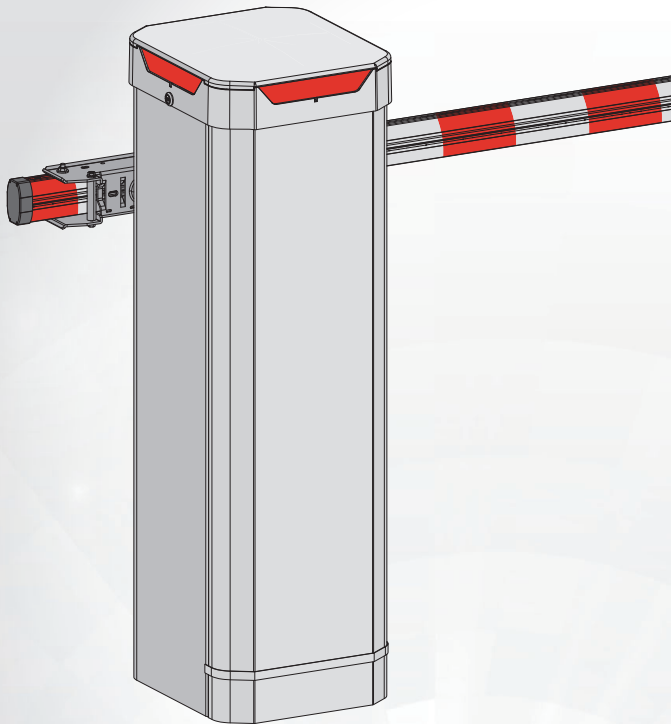

THIS PRODUCT MUST BE INSTALLED AND SERVICED IN ACCORDANCE WITH THIS MANUAL BY A TRAINED GATE SYSTEMS TECHNICIAN ONLY.

- This operator is for use on vehicular passage gates ONLY and not intended for use on pedestrian passage gates.
- All models are intended for use in Class I, II, III, and IV vehicular barrier arm gate applications.
- Visit LiftMaster.com to locate a professional installing dealer in your area.
- This gate operator is compatible with myQ®, myQ® Smart Facility Access™, and Security+ 2.0® accessories.

MODELS

PBG24DCW | PBG24DCG

CBG24DCW | CBG24DCG

IBG24DCW | IBG24DCG



For online troubleshooting and product information scan QR code, or follow link below:

<https://support.partner.liftmaster.com/s/gate-operators-barrier-gates/techna>



LiftMaster
300 Windsor Drive
Oak Brook, IL 60523

TECHNA
LiftMaster®

Table of Contents

Safety	2	Trap/Sequential Merge Operator Sync Mode	47
Safety Symbol and Signal Word Review	2	Parking/Ticketing	48
Usage Class	3	Multi-Vehicle Tracking	48
UL325 Safety Requirements	3	Parking/TicketING Configuration	48
Safety Installation Information	4	Close and Secure Cabinet	49
Role of Dealers, Installers, and Trained Gate System Technicians	4	Install Warning Signs	49
Role of End Users/Property Owners	5	Programming	50
Introduction	6	Antenna Assembly	50
Carton Inventory	6	Security+ 2.0 [®] Transmitters (Not Provided)	50
Arm Selection (Not Provided)	6	Programming Security+3. 0 [™] (SP3) MAX Remote Controls (Not Provided)	51
Operator Specifications	7	Programming Security+3. 0 [™] Keypads and/or Universal Remote Controls (Not Provided)	53
Networking Specifications	9	myQ [®] Smart Facility Access	53
Pre-Installation	10	Setup a myQ [®] Smart Facility Access Account	53
Site Preparation	10	Connect Internet	54
Site Preparation for Safety Devices	11	Operation	58
Operator and Arm Installation Options	11	Service Mode	59
Installation	13	Operator Alarm	60
Determine Location for Operator	13	Maintenance	61
Install the Operator	13	Maintenance Chart	62
Earth Ground Rod	14	Troubleshooting	63
Adjust the Counterbalance Spring Assembly	14	Diagnostic Codes	63
Prepare the Arm	17	Solar	64
Install the Barrier Arm	17	Solar Setup	64
Power Wiring	21	Solar Installation	70
Connect Batteries	23	Repair Parts	72
Install External Safety Devices	24	Accessories	73
Accessory Wiring	25	Warranty	75
MAIN CONTROL BOARD AUXILIARY RELAY	26	Appendix	76
Main Control Board Overview	33	Wiring Diagram	76
Control Board LEDs	33	Removing the Spring Tension for IBG	83
Adjustment	36	Reverse the Spring Handing for IBG	84
Limit, Speed, and Force Adjustment	36	Modify the Spring Count for IBG	84
Configuration	40	Contact Information	85
Operator Configuration	40		
SAMS (Sequence Access Management System) operation	44		
Dual Gate Settings	45		

Safety

Safety Symbol and Signal Word Review

This barrier arm gate operator has been designed and tested to offer safe service provided it is installed, operated, maintained and tested in strict accordance with the instructions and warnings contained in this manual.

When you see these Safety Symbols and Signal Words on the following pages, they will alert you to the possibility of serious injury or death if you do not comply with the warnings that accompany them. The hazard may come from something mechanical or from electric shock. Read the warnings carefully.

When you see this Signal Words on the following pages, it will alert you to the possibility of damage to your barrier arm and/or the barrier arm gate operator if you do not comply with the cautionary statements that accompany it. Read them carefully.

IMPORTANT NOTE:

BEFORE attempting to install, operate or maintain the operator, you must read and fully understand this manual and follow all safety instructions.

DO NOT attempt repair or service of your barrier arm gate operator unless you are a trained gate systems technician.



WARNING: This product can expose you to chemicals including lead, which are known to the State of California to cause cancer or birth defects or other reproductive harm. For more information go to www.P65Warnings.ca.gov

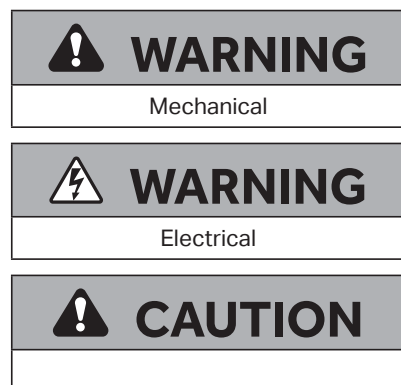

Safety (continued)

Usage Class

CLASS I - RESIDENTIAL VEHICULAR GATE OPERATOR

A vehicular gate operator (or system) intended for use in garages or parking areas associated with a residence of one to four single families.

CLASS II - COMMERCIAL/GENERAL ACCESS VEHICULAR GATE OPERATOR

A vehicular gate operator (or system) intended for use in a commercial location or building such as a multi-family housing unit (five or more single-family units), hotel, garages, retail store, or other buildings accessible by or servicing the general public.

CLASS III - INDUSTRIAL/LIMITED ACCESS VEHICULAR GATE OPERATOR

A vehicular gate operator (or system) intended for use in an industrial location or building such as a factory or loading dock area or other locations not accessible by or intended to service the general public.

CLASS IV - RESTRICTED ACCESS VEHICULAR GATE OPERATOR

A vehicular gate operator (or system) intended for use in a guarded industrial location or building such as an airport security area or other restricted access locations not servicing the general public, in which unauthorized access is prevented via supervision by security personnel.

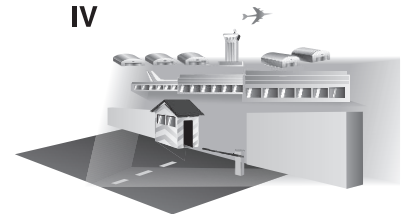
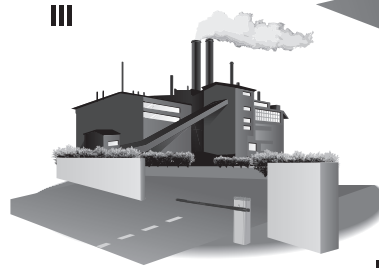
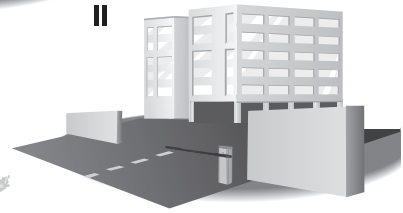

UL325 Safety Requirements

DEFINITIONS

ENTRAPMENT: The condition when a person is caught or held in a position that increases the risk of injury.

REQUIREMENTS

- Do not install operator in a manner in which the arm moves within 16 in. (406 mm) of a rigid object in a location up to 6 ft. (1.8m) above the grade. Examples include walls, ceilings, guard shacks, and posts. Doing so creates an entrapment zone.
- It is the responsibility of the trained gate systems technician/installer to identify and eliminate all possible hazards including pinch points and entrapment zones at the installation site.
- All installations must have the provided warning signs in plain view from both sides of the barrier arm to warn pedestrians of the dangers of motorized barrier arm systems.
- Do not install any signage or anything other than the optional devices such as LEDs, foam edging, edge sensor, or wireless transmitter recommended by the manufacturer, on the moving barrier arm.
- Ensure barrier arm, when open, does not come in close position to high voltage power wires that may be located above or near the barrier arm gate area.

IMPORTANT SAFETY INSTRUCTIONS

WARNING

To reduce the risk of severe INJURY or DEATH:

- READ AND FOLLOW ALL INSTRUCTIONS.
- NEVER let children operate or play with barrier arm gate system. Keep the remote control away from children.
- ALWAYS keep people and objects away from the barrier arm. NO ONE SHOULD CROSS THE PATH OF THE MOVING BARRIER ARM.
- KEEP BARRIER ARMS PROPERLY MAINTAINED. Read this manual. Have a trained gate systems technician make repairs to barrier arm hardware.
- The entrance is for vehicles ONLY. Pedestrians MUST use separate entrance.

SAVE THESE INSTRUCTIONS.

Safety (continued)

Safety Installation Information

1. Vehicular gate systems provide convenience and security. Gate systems are comprised of many component parts. The gate operator is only one component. Each gate system is specifically designed for an individual application.
2. Gate operating system designers, trained gate systems technicians/installers, and users must take into account the possible hazards associated with each individual application. Improperly designed, installed, or maintained systems can create risks for the user as well as the bystander. Gate system design and installation must reduce exposure to potential hazards.
3. A gate operator can create high levels of force in its function as a component part of a gate system. Therefore, safety features must be incorporated into every gate system design. Specific safety features include:
 - Instructional and Precautionary Signage
 - Photoelectric Sensors (non-contact)
 - Edges Sensors (contact)
4. Install the barrier arm gate operator only when:
 - a. The barrier arm gate operator is appropriate for the construction and the usage class of the barrier arm.
 - b. All exposed pinch points are eliminated or guarded.
5. Do not install signage or anything other than the optional devices such as LEDs, foam edging, edge sensor, or wireless transmitter recommended by the manufacturer, on the barrier arm.
6. The barrier arm gate operator is intended for installation only on passageways used for vehicles. Pedestrians must be supplied with a separate access opening. The pedestrian access opening shall be designed to promote pedestrian usage.
7. Locate the barrier arm gate operator such that persons will not come in contact with the barrier arm during the entire path of travel of the barrier arm.
8. The barrier arm gate operator must be installed in a location so that enough clearance is supplied between the barrier arm and adjacent structures when opening and closing to reduce the risk of entrapment. When the swing away arm bracket is utilized, ensure it does not open into pedestrian walkways.
9. Permanently mounted access controls intended for users to activate the barrier arm, must be located at least 6 feet (1.8 m) away from any moving part of the barrier arm gate operator system and where the user is prevented from reaching over, under, around or through the gate system to operate the controls. Outdoor or easily accessible controls shall have a security feature to prevent unauthorized use. Exception: Emergency access controls, only accessible by authorized personnel (e.g. fire, police, EMS), may be placed at any location in the line-of-sight of the gate.
10. For a gate operator utilizing a Stop button, it must be located in the line-of-sight of the gate.
11. A minimum of two (2) WARNING SIGNS shall be installed in the area of the barrier arm. Each warning sign is to be visible by persons located on the side of the barrier arm on which the sign is installed. Two (2) WARNING SIGNS are provided with this operator. See page 49.
12. When a hard wired contact sensor is installed, it shall be located and its wiring arranged so the communication between the sensor and the gate operator is not subject to mechanical damage. A wireless edge transmitter kit must be used with the contact edge sensor.
13. A wireless device such as one that transmits radio frequency (RF) signals to the gate operator shall be located where the transmission of the signals is not obstructed or impeded by building structures, natural landscaping or similar obstruction. A wireless device shall function under the intended end-use conditions.

Role of Dealers, Installers, and Trained Gate System Technicians

- Ensure entire barrier arm gate system is designed, manufactured and installed to meet all applicable standards and codes including UL 325.
- Demonstrate the basic functions and safety features of the barrier arm gate system to owners/end users/general contractors, including how to turn off power.
- Leave safety instructions, product literature, installation manual, and maintenance manual with end user.
- Explain to the end users and property owners the importance of testing by a trained gate system technician that includes a routine re-testing of the entire system, including any safety devices, and explain the need for the owners to ensure that this testing is performed monthly.

Safety (continued)

Role of End Users/Property Owners

- Contact a trained gate systems technician to maintain and repair the gate system (end users should never attempt to repair the gate system).
- Retain and utilize this installation manual including its maintenance and important safety instructions.
- Routinely check all barrier arm gate operator functions and barrier arm movement.
- Discontinue use if systems operate improperly, the barrier arm or gate operator is damaged, or the barrier arm is difficult to move. Contact trained gate systems technician to repair the barrier arm gate system.
- Prominently display and maintain warning signs on both sides of the barrier arm gate area.

Introduction

Carton Inventory

NOTE: Operator does not include arm. Please see "Operator and Arm Installation Options" on page 11 for arm selection and operator compatibility below.

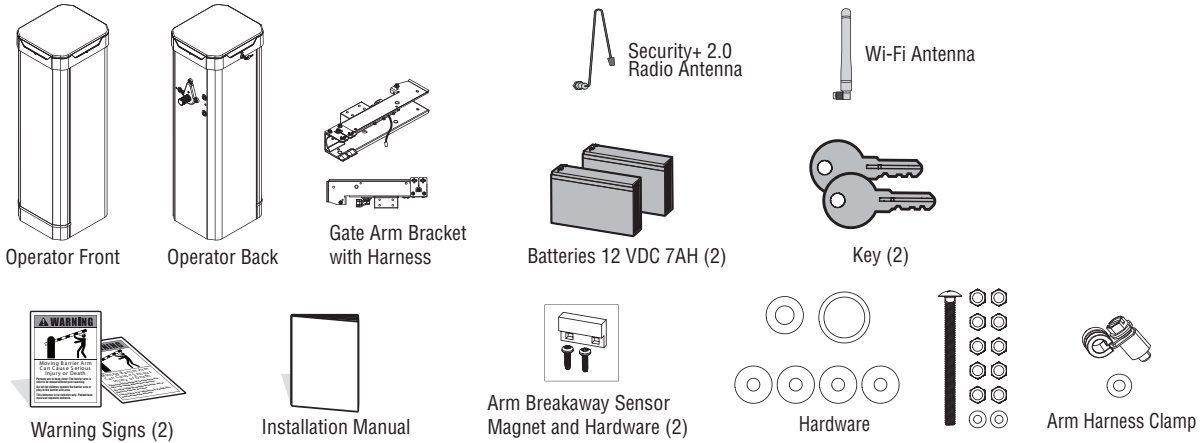

Arm Selection (Not Provided)

ATTENTION: MUST ORDER CORRECT LIFTMASTER ARM FOR THE INDIVIDUAL SITE APPLICATION SEPARATELY. ONLY LIFTMASTER ARMS ARE UL CERTIFIED WITH THE OPERATOR.

Straight Arms	Description	Operator Compatibility
BGARM10	10' Functional Length Arm	CBG
BGARM10LED	10' Functional Length Arm w/LED	CBG
BGARM12	12' Functional Length Arm	CBG
BGARM12LED	12' Functional Length Arm w/LED	CBG
BGARM14	14' Functional Length Arm	CBG
BGARM14LED	14' Functional Length Arm w/LED	CBG
PBGARM10	10' Functional Length Arm	PBG
PBGARM10LED	10' Functional Length Arm w/LED	PBG
PBGARM12	12' Functional Length Arm	PBG
PBGARM12LED	12' Functional Length Arm w/LED	PBG
IBGARM18	18' Functional Length Arm	IBG
IBGARM24	24' Functional Length Arm	IBG

NOTE: LED arms come with one LED strip. The system is designed to use one LED strip/arm.

Articulated Arms	Description	Operator Compatibility
BGARM10ART84	10' Functional Length Arm with 84" Clearance	PBG
BGARM10ART98	10' Functional Length Arm with 98" Clearance	PBG
BGARM12ART84	12' Functional Length Arm with 84" Clearance	PBG
BGARM12ART98	12' Functional Length Arm with 98" Clearance	PBG

NOTE: Clearance height is measured from the base of the operator to the bottom of the articulated arm when in the open position.

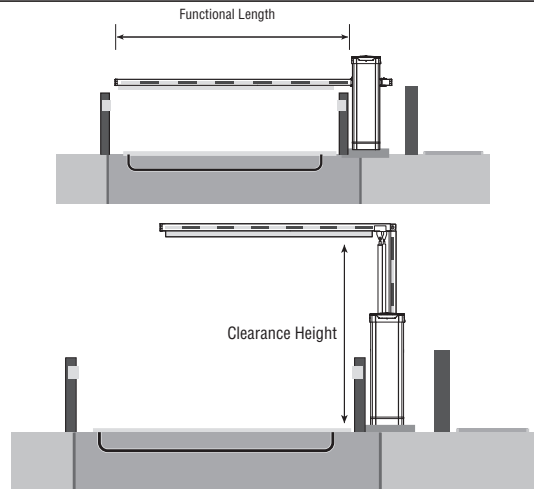

Introduction (continued)

Operator Specifications

	PBG24DCW, PBG24DCG Parking Operator	CBG24DCW, CBG24DCG Commercial/ Community Operator	IBG24DCW, IBG24DCC Industrial Operator
Colors Available	White, Charcoal		
Usage Classification	Class I, II, III, and IV		
Maximum Functional Arm Length	12 feet	14 feet	24 feet
Open / Close Time	1.9 seconds	2.5 seconds	6 seconds
Duty Cycle	Continuous		
Main AC Supply	120 VAC single phase, 12.5 Amps including Accessory Outlets OR 240 VAC single phase, 3.5 Amps		
Optional Transformer Kit	When Optional Transformer Kit Model 3PHCONV is installed in the field, operator is rated phase-to-phase. 208/240/480/575 VAC, 5.2/4.5/2.3/1.9 A, 60 Hz, 1 PH		
System Operating Voltage	24 VDC Transformer Run / Battery Backup		
Accessory Power	24 VDC, 1A max. for ON + SW (switched)		
Solar Power Max	24 VDC, 80 Watts max.		
Operating Temperature	Without Heater: -20°C to 60°C (-4°F to 140°F) With Optional Heater: -40°C to 60°C (-40°F to 140°F)		
120 VAC accessory power outlets	6 Amps max When the 3PHCONV kit is used, the outlets are rated 1 Amp max Accessory Power Outlets disabled when powered with 240VAC NOT using 3PHCONV kit		
Safety Device Inputs	Main control board maximum capacity: Up to 2 safety devices in close direction and 1 safety device in open direction. Expansion board maximum capacity: Up to 3 safety devices configurable to either the close or open direction. ATTENTION: If an edge sensor is being integrated into this system, and installed on the arm, use a wireless edge kit. If a wired edge is used, there is risk of wire damage in the gate arm bracket. See "Site Preparation for Safety Devices" on page 11 for additional details.		
Operating Wind Force	60 mph max		

Introduction (continued)

Top View of Cabinet Footprint

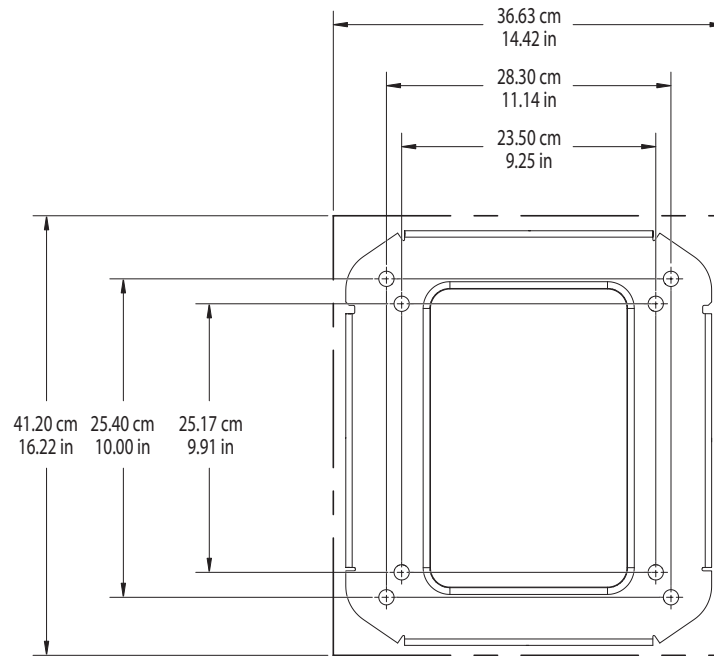

TECHNA arm bracket size differs by model (PBG is shorter) - See below for measurements.

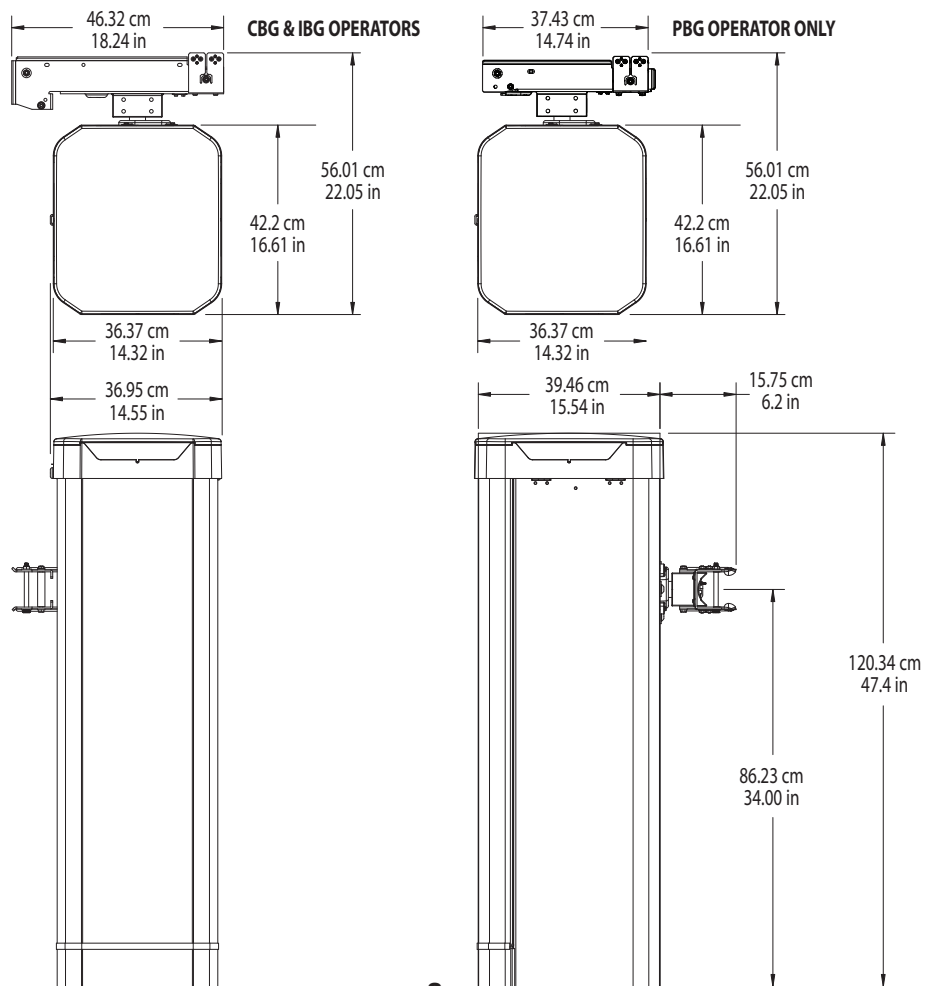

Introduction (continued)

Networking Specifications

Ethernet Compatibility	10 Mbps / 100 Mbps Ethernet
Wi-Fi® Compatibility	802.11 b/g/n 2.4 GHz
Wi-Fi® Security	Operator is compatible with routers using the following security protocols: WPA3-Personal (SAE) (Recommended), WPA2-PSK (AES), WPA2-PSK (TKIP), WPA2 Personal, WPA-PSK (AES), and WPA-PSK (TKIP). Operator is NOT compatible with routers using the following security protocols: WPA3-Enterprise, WPA2-Enterprise, WEP, Open (No password or encryption).
Wi-Fi® Range	Up to 500 feet (152.4 m), Open Air/Line-of-Sight (range varies depending on obstructions)
LiftMaster Radio Compatibility	Security+ 2.0®
Wireless Communication to LiftMaster Access Control	Up to 1500 feet (450 m), Open Air/Line-of-Sight (range varies depending on obstructions), Compatible with LiftMaster CAPX Access Control Systems

INTERNET REQUIREMENTS

When selecting a router, use the information below to ensure compatibility.

The operator can be connected to a router via a wired connection or Wi-Fi®. LiftMaster recommends an Internet speed of 5Mbps download speed, 5Mbps upload speed.

Operator is compatible with routers using the following Wi-Fi® communication protocols:

- 802.11b
- 802.11g
- 802.11n

ADDITIONAL COMPATIBILITY CONSIDERATIONS

- Don't use Wi-Fi® extender devices. These may introduce latency in the connection leading to a choppy connection.
- If using a Wi-Fi® signal strength tool or app, you must ensure a continuous Wi-Fi® signal strength connection of at least -65 dBm (numbers closer to zero indicate a stronger signal strength) at the operator location for an acceptable connection to the local network.
- Hidden network SSID's are not supported.
- Wi-Fi® networks requiring secondary authentication are not supported, e.g., hotels and airport Wi-Fi®.
- A signal strength of at least two bars is recommended and can be checked through operator LCD screen.
- If two bars are not available, relocate the router, if using an antenna extension kit move the operator antenna higher up or to a location resulting in two or more bars.

Pre-Installation

⚠ WARNING

- The entrance is for vehicular traffic ONLY. Pedestrians MUST use a separate entrance.
- Do not install operator in a manner in which the barrier arm moves within 16 in. (406 mm) of a rigid object in a location up to 6 ft. (1.8 m) above the grade. Examples include walls, ceilings, guard sheds, and posts. Doing so creates an entrapment zone.
- Ensure the barrier arm, when open, does not come in close position to high voltage power wires that may be located above or near the barrier arm gate area.

Site Preparation

Recommendations for site preparation for barrier arm gate operator installation. Every installation is unique. It is the responsibility of the installer to ensure the barrier arm gate operator is installed in a safe manner. If the area surrounding the barrier arm gate operator is expected to have high pedestrian traffic, it is recommended that safety devices, such as LiftMaster photoelectric sensors or wireless edge sensors, be installed at the site.

When gate arms are in the vertical position or rotated to an open position, the closest part of the gate arm and support shall have a lateral offset of at least 2 feet from the face of the curb or the edge of the traveled way.

Bird's Eye View

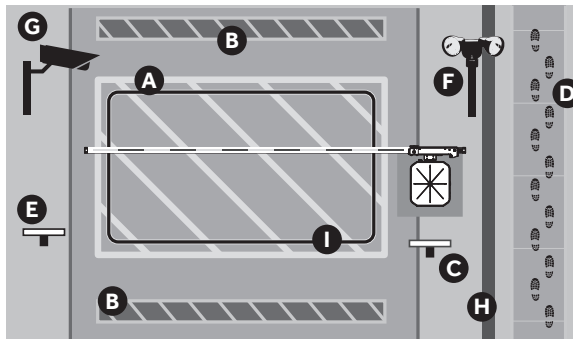

Ground-Level View

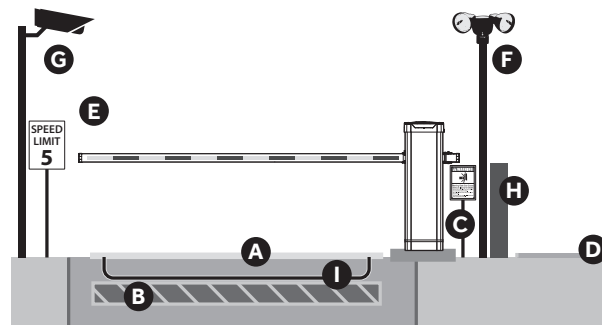

A	Caution Lines	Permanently fix caution lines under travel of arm indicating a no stopping or standing zone. When the swingaway mounting style is used, the swing radius of the arm should be marked on the pavement with caution lines.
B	Speed Bump	Permanently fix speed bump on both sides of roadway at a straight angle, to slow traffic. At minimum of 6 feet away from barrier arm.
C	UL Warning Signs (Two Required)	Permanently fix the two required UL warning signs in the area of the barrier arm gate operator. Each warning sign is to be visible by persons located on each side of the barrier arm gate operator on which the warning sign is installed. See page 49.
D	Pedestrian Access	If pedestrian traffic is in the vicinity of the barrier arm gate operator, a separate pedestrian entry/exit must be clearly visible to promote pedestrian usage and located so pedestrians do not come in contact with the barrier arm. Partition/barrier from vehicular traffic is recommended when possible. See callout H.
E	Speed Limit Sign	Recommend installing a permanently fixed lighted speed limit sign within line of sight from both sides of roadway. Recommended 5mph.
F	Perimeter Lighting	Recommend installing perimeter lighting to create awareness of the area surrounding the barrier operator. If the swingaway mounting style is used, the lighting should be placed outside the swing radius of the arm.
G	Cameras	Install cameras to record operation and deter unwanted operation.
H	Partition/Barrier	Separation between vehicle and foot traffic.
I	Exit, or Reversing (Interrupt) Loop	Protect property and manage the flow of traffic with an inground loop that reverses a closing arm for vehicle detection.

Pre-Installation (continued)

Site Preparation for Safety Devices

Every installation is unique. It is the responsibility of the installer to ensure the barrier arm gate operator is installed in a safe manner. If the area surrounding the barrier arm gate operator is expected to have high pedestrian traffic, it is recommended that safety devices, such as LiftMaster photoelectric sensors or wireless edge sensors, be installed at the site. See "Safety Devices" on page 73 for acceptable devices.

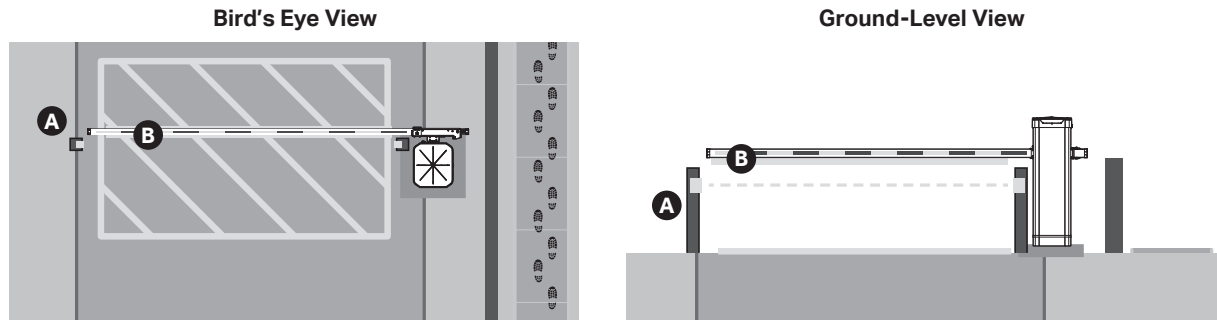

A	Non-contact sensor	<p>When a non-contact sensor is used, it is recommended to permanently fix the sensor under the path of barrier arm. Recommended to mount sensor between 21"-27" above grade.</p> <p>NOTE: Do not mount on the operator directly.</p> <p>WARNING: Never use a non-contact sensor, microwave sensor OR any motion activated detection device to provide a close command to the barrier arm operator. This can be dangerous and is not recommended.</p>
B	Contact sensor	<p>When a contact sensor is used, it should be mounted to the bottom of the barrier arm in the existing channel. A wireless edge sensor is the only contact sensor supported by this system. This system does not support a hardwired edge sensor.</p>

CAUTION

<ul style="list-style-type: none"> To AVOID damaging gas, power or other underground utility lines, contact underground utility locating companies BEFORE digging more than 18 inches (46 cm) deep. In the US, call 811. 	<ul style="list-style-type: none"> Permanent wiring is to be employed as required by local codes. It is important to ensure proper grounding of the unit. To avoid creating an entrapment zone, do not install this vehicular barrier arm gate operator in a manner in which the arm moves within 16 in. (406mm) of a rigid object in a location up to 6ft. (1.8m) above grade. Examples include walls, ceilings, posts, pillars, columns, or guard shack.
---	--

Operator and Arm Installation Options

NOTE: The Barrier Arm is not included and must be purchased separately. See "Accessories" on page 74.

First determine the handing, which is the direction of the arm when in the "closed" as viewed when facing the opening of the cabinet.

Second determine the installation type. This will determine how the arm will move when dislodged from the arm bracket during a vehicle strike into the arm. See page 18 for a table of these options, which includes Swingaway (pivot), Breakaway (falls perpendicular to the lane) and Fixed Arm.

CAUTION: If the Fixed arm set up is used, damage to the operator may occur during a vehicle strike into the arm.

HANDING OPTIONS

The barrier arm gate operator may be installed with right-hand or left-hand operation.

See the image to determine the handing in relation to the operator when facing the opening of the cabinet.

Pre-Installation (continued)

COUNTERBALANCE SPRINGS DIRECTION

The arrow of each installed spring must point in the direction of the arm in the closed position for left- or right-handing. The counterbalance spring assembly comes from the factory in the right-handed configuration.

Springs are not removed during handing changes. For instructions to change to left-handed configuration, see "REVERSE THE SPRING HANDING" on page 15.

NOTE: The barrier must be fully open (arm/bracket in the vertical position) before modifying the counterbalance spring assembly.

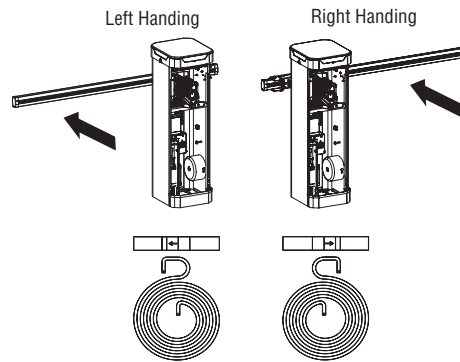

WARNING: FOLLOW THE STEPS OUTLINED IN "REMOVING SPRING TENSION" TO ENSURE THAT ALL TENSION IS RELEASED FROM SPRINGS PRIOR TO REMOVING BOLTS, OR THE END PLATE.

ARM INSTALLATION TYPE OPTIONS

(See page 18 for the arm installation instructions)

When choosing the arm installation type, the Breakaway setup is recommended for PBG and CBG operator models. With this setup, the arm will fall perpendicular to the lane when a low-speed vehicle strike to the arm occurs.

A second, optional, arm installation type is the Swingaway setup, compatible with the PBG and CBG operator models. With this setup, the arm will pivot and swing away from the vehicle when a low-speed vehicle strike to the arm occurs. The entire swing radius of the arm must be clear of obstacles.

WARNING: THE SWINGAWAY OPTION PEDESTRIAN AND OBJECT CLEARANCES TO THE ROADWAY ON THE SIDE OF OPERATOR A MINIMUM OF 7 FT FROM OUTER EDGE OF OPERATOR.

ARM SWINGAWAY SETUP (OPTIONAL) (NOT INCLUDED, OR RECOMMENDED FOR IBG)

When using the Arm Swingaway System, the barrier arm will pivot in the outward direction only, away from the operator. Ensure the entire swing radius of the arm is clear of any obstacles.

Arm Setup with Outward Swingaway

The arm can be installed on the arm bracket to pivot and swingaway outwards away from the operator.

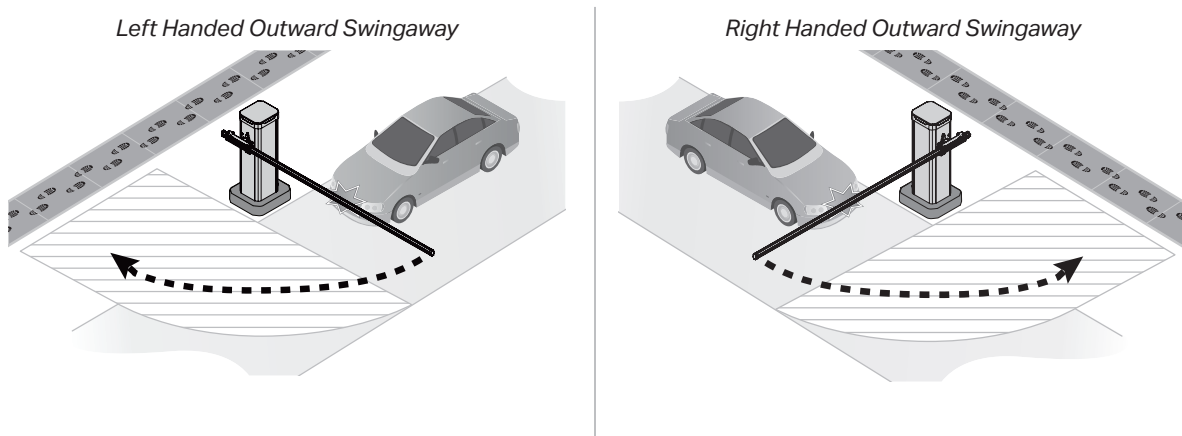

Installation

1 Determine Location for Operator

Check the national and local building codes before installation.

1. Lay out the concrete pad.
2. Install the electrical conduit.
3. Pour a concrete pad (reinforced concrete is required).

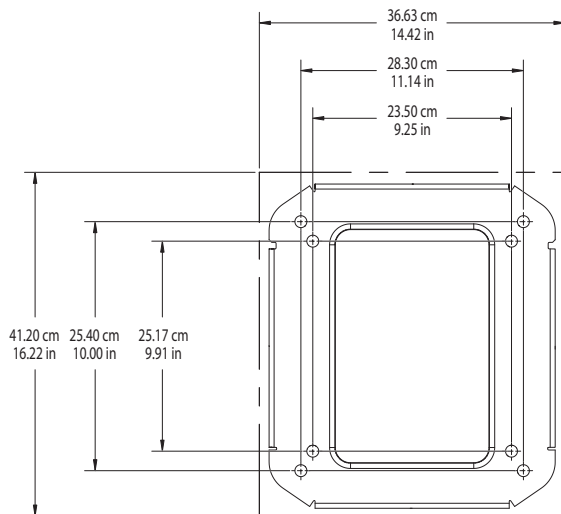
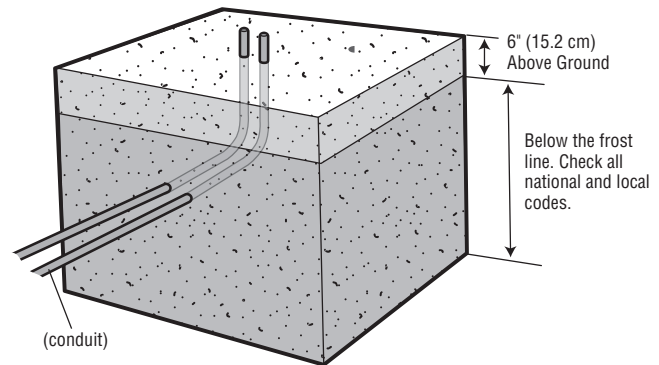

**Know what's below.
Call before you dig.**

2 Install the Operator

Attach the operator to the concrete pad with appropriate fasteners.

1. If replacing an existing operator, determine whether the existing bolt mounting pattern is compatible with the operator.
2. If installing a new operator, see bolt mounting pattern dimensions above to mark the locations for drilling the bolts.
3. Drill the bolts into the concrete. Use the four (4) oversized washers when attaching the operator to the pad.

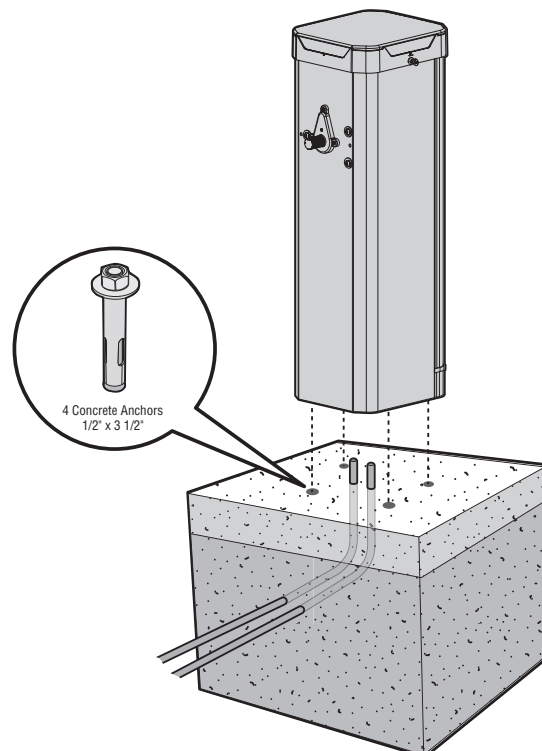

Installation (continued)

3 Earth Ground Rod

Use the proper earth ground rod for your local area. The ground wire must be a single, whole piece of wire. Never splice two wires for the ground wire. If you should cut the ground wire too short, break it, or destroy its integrity, replace it with a single wire length.

NOTE: If the operator is not grounded properly, the range of the remote controls is reduced and the operator is more susceptible to lightning and surge damage.

NOTE: DO NOT ground operator to a fence, gate, or pipe.

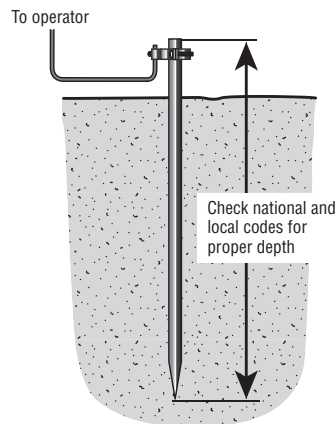

4 Adjust the Counterbalance Spring Assembly

The counterbalance spring assembly comes from the factory in the right handed configuration with the number of springs to support the longest arm compatible with the model and most accessories installed.

1. Verify the arm length and which accessories will be attached to the arm. Use the table below to identify how many springs should be used. See "Operator and Arm Installation Options" on page 11 for details on handing.
 - a. If springs need to be removed, see "Modify Spring Count" on page 16.

NOTE: Removing and reinstalling individual springs in the opposite direction does NOT switch the operator handing due to spring protection switch functionality. The entire carrier should be used to swap spring handing as shown "Modify Spring Count" on page 16.

Spring Count Table (CBG and PGB)						
Functional Arm Length (ft)*	Bare Arm	One LED Strip	Foam Insert	Foam Insert, One LED Strip	Edge	Edge, One LED Strip
8	3	3	3	3	4	4
9	4	4	4	4	5	5
10	5	5	5	5	6	6
11	6	6	6	6	7	7
12	7	7	7	7	7	7
13	8	8	8	8	9	9
14	9	9	9	9	9	9

ATTENTION: Maximum arm length for PGB models is 12', CBG models is 14'.

Spring Count Table Articulating Arm				
Length (ft)*	Articulating Height (in)*	Standard Arm	One LED Strip	Two LED Strips
10	84	5	5	5
10	98	6	6	6
12	84	5	5	5
12	98	7	7	7

Installation (continued)

ADJUSTING THE NUMBER OF SPRINGS

The number of springs will need to be adjusted if you have less than a 24' arm. The arm is measured as the length that will extend beyond the length of operator into the lane.

Please see the chart below for the number of springs you will need for:

Springs Needed for IBG										
Arm Length (ft)*	15'	16'	17'	18'	19'	20'	21'	22'	23'	24'
Number of Springs	6	7	7	8	9	9	10	10	11	11

Note: If you notice poor quality of motion, try adding or removing another spring to the system.

! WARNING

Springs may be under tension. The tension on the counterbalance spring system must be released or removed prior to loosening or removing the bolts or any components of the spring system. See "Removing Spring Tension" below.

REMOVING SPRING TENSION

ATTENTION: The steps below must be used to safely remove springs from a **PBG** or **CBG** operator. They allow the spring assembly to disengage from the gearbox while it is still mounted in place.

1. Locate the three bolts that attach the spring assembly to the gearbox. Using a socket wrench and extension to avoid accidental contact with the loaded springs inside the cabinet enclosure, loosen each screw by three (3) full rotations only. Do NOT fully remove these bolts yet.

NOTE: The spring protection limit switch harness does NOT need to be removed during this operation.

2. Use a flathead screwdriver or pry bar around the edges of the spring assembly to disengage it from the gearbox, avoiding contact with the springs and center hub. **Do not use hands or body to release tension.**
3. Verify the springs are loose before removing the three bolts completely. The shaft of the spring assembly should be able to freely move a few degrees when nudged with a screwdriver if the springs are disengaged.
4. If the springs do not disengage repeat step 2, if that is unsuccessful call technical support.

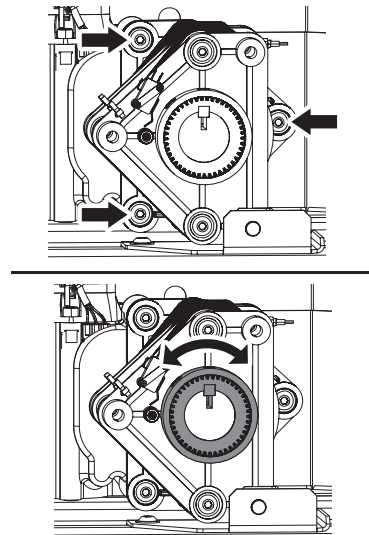

WARNING: If these steps do not work to remove the spring tension, contact Technical Support for instruction on alternate method. DO NOT USE EXCESSIVE FORCE TO DISENGAGE SPRINGS FROM GEARBOX. SEVERE INJURY MAY OCCUR.

* For IBG see page 83.

Installation (continued)

SPRING PROTECTION LIMIT SWITCH

There is a spring protection limit switch which on contact causes the operator to cease operation in the direction of travel. This is done to protect the counterbalance springs from turning in the wrong direction, or overtightened/overwound during commissioning, which could cause damage and shorten durability life.

The purpose of the spring protection limit switch is to prevent damage to the balance system. If prompted by the operator display, perform the following steps to release the switch and resume normal operation/commissioning.

ATTENTION: The spring protection limit switch stays in the same position on the spring hub assembly in both RH & LH orientation/installations. It never moves only the counterbalance spring assembly flips.

1. Re-establish limit switch circuit continuity by performing one of the following steps:
 - Remove spring protection switch mounting screws.
 - Remove terminals on spring protection switch and jumper the two wires together.
2. Rotate output shaft position by performing one of the following steps:
 - If counterbalance springs are pointing right, press up button to move arm counterclockwise until spring assembly shaft key is pointing up (12 o'clock position).
 - If counterbalance springs are pointing left, press down button to move arm clockwise until spring assembly shaft key is pointing up (12 o'clock position).
3. Restore Limit switch circuit to original state by reversing the option chosen in step 1:
 - Re-install mounting screws
 - Remove jumper and reconnect terminals to switch COM and NC terminals.
4. Verify arm position is in the vertical position.
5. Verify spring assembly orientation matches intended handing.
6. Enter Limit Learn mode and set the limits.

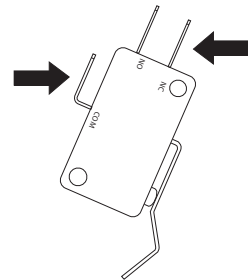

REVERSE THE SPRING HANDING (FOR PBG AND CBG)

PRIOR TO REMOVING SPRING CARRIER BOLTS, ENSURE SPRING TENSION IS RELEASED. SEE PAGE 15 FOR MORE DETAIL

Remove the counterbalance spring assembly by removing three screws that attach the counterbalance spring assembly to the gearbox. Take care not to damage the spring protection limit switch harness.

1. Rotate the counterbalance spring assembly 180° so that the two end plates swap position. The spring arrows should still be on the top of the assembly after rotating.
2. Install the three attachment screws again to secure the counterbalance spring assembly to the gearbox. Torque the 3 bolts fastening the counterbalance spring assembly to **19ft-lb**.

NOTE: Removing and reinstalling springs in the opposite direction does NOT work to switch the handing of the unit due to the spring protection limit switch functionality. The entire counterbalance spring carrier must be reversed to change the spring handing. The spring protection limit switch stays in the same position on the hub during this process.

* For IBG see page 84.

MODIFY SPRING COUNT(FOR PBG AND CBG)

1. Remove the hub by loosening the two set screws and spring protection limit switch bolt if necessary and sliding it off (see image A).
2. Remove the end plate by removing the two screws (see image A). If the plate contains the spring protection limit switch, ensure that it is not damaged or unplugged. If it does become unplugged, ensure that it is rewired as a Normally Closed (NC) switch. See "Spring protection limit switch" above for more details.
3. Remove unneeded springs and spacers by sliding them off (see image B).
4. Add retention collars (provided in the pack in bag) in place of the removed springs. These retention collars prevent the springs from sliding out of place during operation (see image C).
5. Replace end plate and tighten the two end plate screws to **22ft-lb** (see image C.)
6. Replace hub and tighten the two set screws to **25ft-lb** (see image C).

* For IBG see page 84.

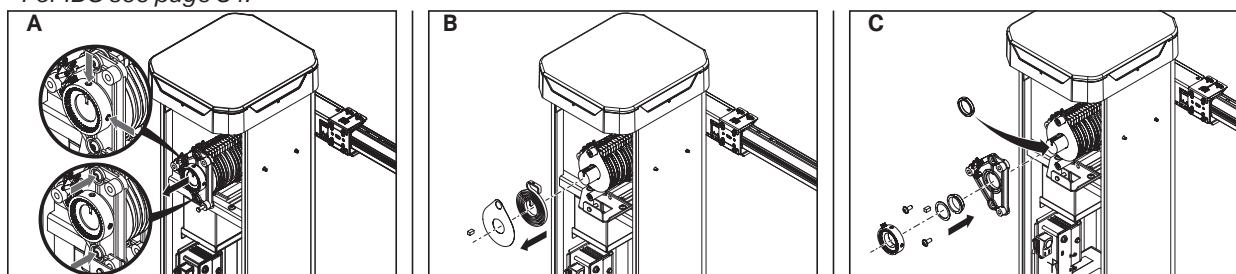

Installation (continued)

5 Prepare the Arm

1. Reference arm installation instructions included with the arm packaging. Arm should be mounted with the edge mounting channel facing down towards the ground.
2. Arm Sensor Mounting: The arm sensor is required to be installed properly on all arm installation types (swing away, breakaway and fixed). The operator will not run if this arm sensor is not installed properly. The arm's magnetic sensor is pre-installed inside the bracket. The magnet needs to be mounted on the arm for proper detection of the arm. See image for reference.

NOTE: The bracket magnet position is fixed. The position of the magnet on the arm needs to align with the sensor in the arm bracket to communicate properly. The two flat portions should make contact as shown in image shown.

NOTE: The magnet position is fixed in the bracket. The position of the magnet on the arm needs to align with the magnet in the bracket. The two flat portions should make contact as shown in figure.

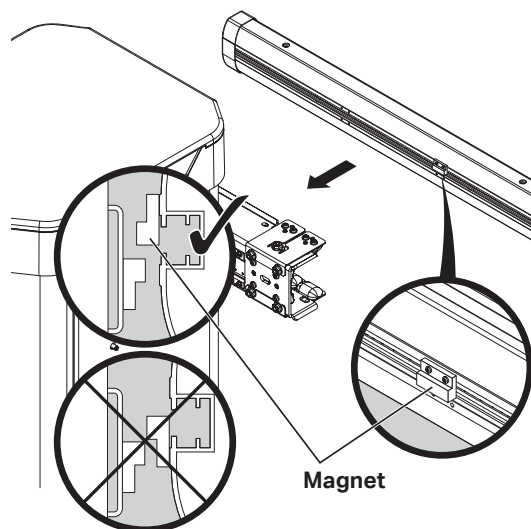

6 Install the Barrier Arm

ATTENTION: Torque the 3 bolts fastening the counterbalance spring assembly to **19ft-lb**. If springs are removed, the hub set screws and the 2 end plate bolts need to be torqued to **22ft-lb**.

ATTENTION: Before installing the arm, verify the arrow printed on the spring's points in the intended direction of the arm in the closed position. If it does not, refer to "Removing Spring Tension" on page 15 for instructions.

1. Ensure the operator is powered off.
2. Remove the operator cabinet door and set aside.
3. Unpack the arm bracket and hardware from the operator cabinet.
4. Cut the barrier arm to desired length if modification is necessary.

IMPORTANT: DO NOT CUT END WITH MOUNTING SYSTEM (HOLES FOR MAGNET AND FIXED BOLT). Arm base section will always have the connector segment assembled and should not be cut. The 6ft section should be cut for 10ft arms, and the 2ft and 4ft sections (for 12ft and 14ft foot arms respectively) should be the cut sections for those arm lengths.

5. Verify that the appropriate number of counterbalance springs are installed and align the arrows to match the intended arm direction. If the arrows pointing opposite the intended arm direction, remove the counterbalance spring assembly and flip to ensure the arrows align with the intended arm direction. Follow the instructions and warnings in "Modify Spring Count" on page 16.
6. Loosen the four hub bolts on the arm bracket and remove the pivot bolt from the arm bracket.
7. Slide the arm bracket on to the output shaft of the operator. Do NOT tighten down the hub bolts. The arm bracket should freely rotate at this point.
8. With the far end of the arm resting on the ground, push the arm into the arm bracket. Be sure to install the arm with the arm magnet toward the operator.
9. Choose the arm installation type using the table on page 18 and follow the corresponding instructions.

Installation (continued)

Arm Installation Table

Swingaway Arm Installation (compatible with PBG and CBG models)	Breakaway Arm Installation (recommended for PBG and CBG models)	Fixed Arm Installation (Required for IBG and compatible with PBG and CBG models) ** Permanent damage may occur to the system if the arm is struck.
<ol style="list-style-type: none"> 1. Install the pivot bolt (removed earlier) through the bracket and arm. 2. Tighten the nut to the pivot bolt. 	<ol style="list-style-type: none"> 1. Install the two 3-inch carriage bolts through the back of the arm bracket and through the arm. 2. Install a flat washer and nylon nut to each. 3. Ensure that pivot pin is not in place. If it is, the arm will pivot when dislodged instead of being dislodged perpendicular to the lane. 	<ol style="list-style-type: none"> 1. Install the pivot bolt to the back end of the arm and secure with a flat washer and metal nut. 2. Fix the breakaway shut by installing a carriage bolt through the back of the arm bracket and through the arm. 3. Install a flat washer and metal nut to each.

For Commercial Operator: CBG

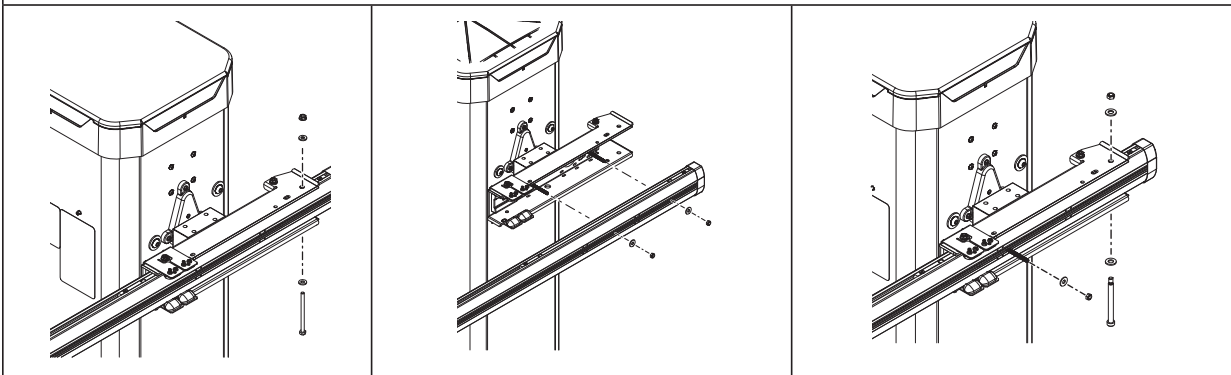

For Parking Operator: PBG Models

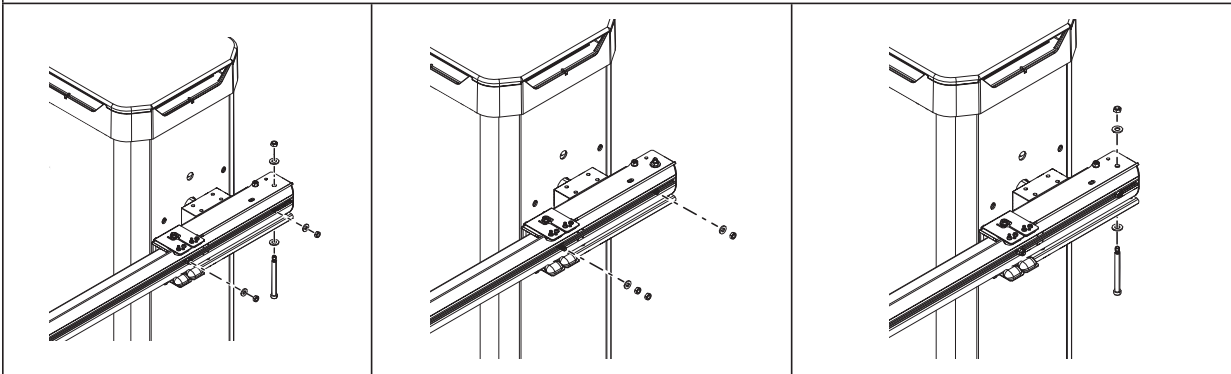

DO NOT TIGHTEN HUB BOLTS ON OUTPUT SHAFT UNTIL ROTATED TO THE VERTICAL POSITION.

LED CABLE ROUTING MAY CHANGE BASED ON ARM INSTALLATION METHOD. AVOID PINCH POINTS.

Installation (continued)

- Rotate the arm bracket vertically so that the arm is in the open position.
NOTE: Fasten each of the four hub bolts with the arm in vertical position.

- Torque each of the four hub bolts to **60 ft-lb for CBG/PBG and 80ft-lb for IBG (CRITICAL)**. If this step is missed, an RPM stall fault and/or limit drift will occur.

NOTE: Tighten the bolts in a cross order as shown in the picture to the right. Snug the bolts repeatedly before reaching full torque. At the end double check that all bolts are tightened to **60 ft-lb for CBG/PBG and 80ft-lb for IBG**.

- Connect the operator wiring harness to the arm bracket wire harness.
- Route the arm bracket wiring harness through the arm harness clamp, see image on page below for appropriate arm harness cable routing.. Install harness arm harness clamp to the appropriate location for the handing of the operator using the standoff and washer (see image below).

- If an LED strip is being installed, connect the LED strip connector to the mating connector on the arm bracket harness (see detailed instructions included in the LED instruction sheet).
NOTE: Fasten each of the four hub bolts with the arm in vertical position.

- Torque each of the four hub bolts to **60 ft-lb for CBG/PBG and 80ft-lb for IBG (CRITICAL)**. If this step is missed, an RPM stall fault and/or limit drift will occur.
Note: Tighten the bolts in a cross order as shown in the picture to the right. Snug the bolts repeatedly before reaching full torque. At the end double check that all bolts are tightened to **60 ft-lb for CBG/PBG and 80ft-lb for IBG**.

- Connect the operator wiring harness to the arm bracket wire harness.
- Route the arm bracket wiring harness through the arm harness clamp, see image on page below for appropriate arm harness cable routing. Install harness arm harness clamp to the appropriate location for the handing of the operator using the standoff and washer (see image below).
- If an LED strip is being installed, connect the LED strip connector to the mating connector on the arm bracket harness (see detailed instructions included in the LED instruction sheet).

NOTE: If Spring protection limit switch on the spring assembly is pressed, see Spring Protection limit switch section on page 16 for instructions on how to reset it. Ensure the springs are in the correct orientation for the arm direction and begin setting limits. Start with the arm in the vertical/open position.

NOTE: Be sure to route and zip-tie the LED cable to the bracket, taking care to avoid any pinch points due to moving parts.

FIXED BARRIER ARM SENSOR SETUP

See image below for appropriate arm harness cable routing.

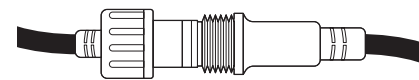
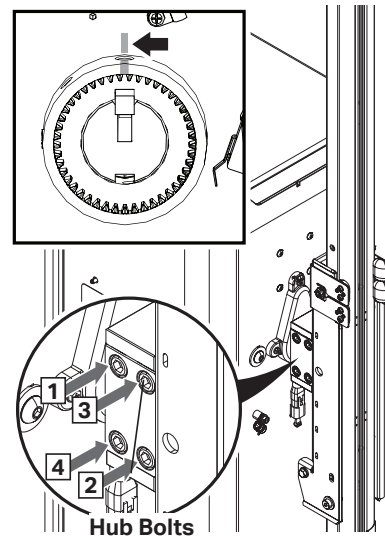
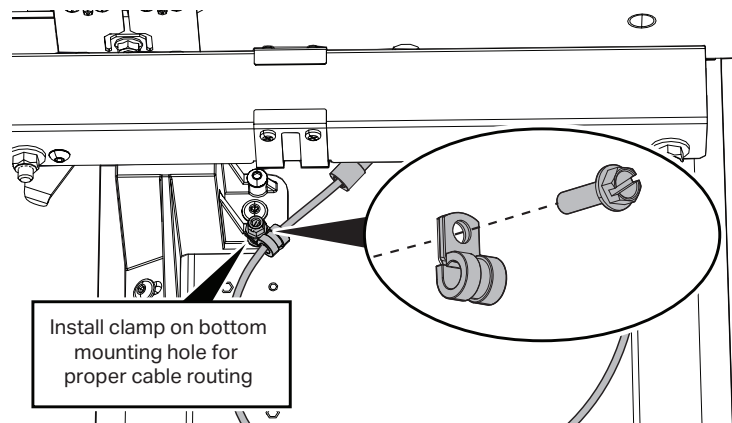

Installation (continued)

The Fixed Barrier Arm Setup also requires the use of an arm sensor that is located on the arm bracket and a magnet that is located on the arm to detect the presence of the arm.

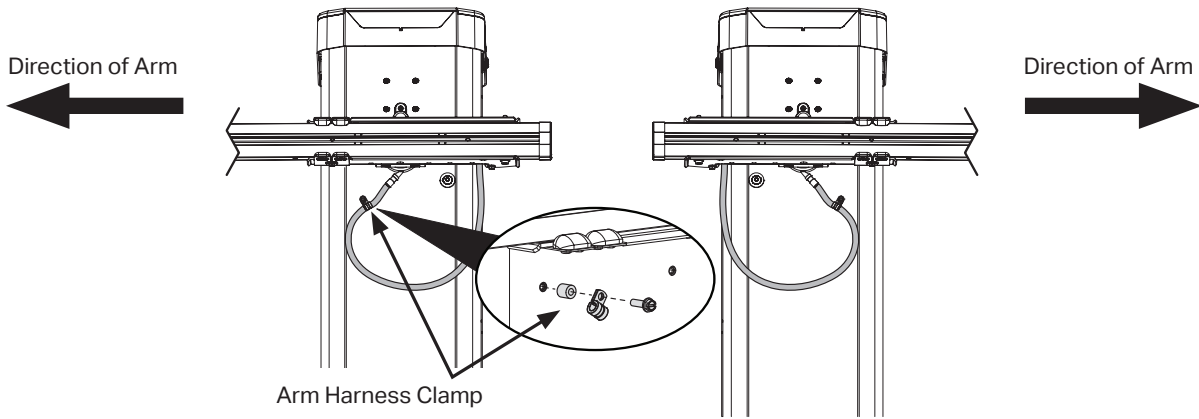

NOTE: Arm Harness Clamp installation differs for articulating arm setups. See arm instructions for details.

Installation (continued)

7 Power Wiring

WARNING

To reduce the risk of SEVERE INJURY or DEATH:

- ANY maintenance to the operator or in the area near the operator MUST NOT be performed until disconnecting the electrical power (AC or solar and battery) and locking-out the power via the operator power switch. Upon completion of maintenance the area MUST be cleared and secured, at that time the unit may be returned to service.
- Disconnect power at the fuse box BEFORE proceeding. Operator MUST be properly grounded and connected in accordance with national and local electrical codes.

NOTE: The operator should be on a separate fused line of adequate capacity.

- ALL electrical connections MUST be made by a qualified individual. DO NOT install ANY wiring or attempt to run the operator without consulting the wiring diagram.
- ALL power wiring should be on a dedicated circuit and well protected. The location of the power disconnect should be visible and clearly labeled.
- ALL power and control wiring MUST be run in separate conduit.

The operator can be wired for either 120 VAC or 240 VAC or a solar panel (not provided). Follow the directions according to your application. An optional Transformer Kit (Model 3PHCONV) can be installed as an added accessory offered change the input voltage (208/240/480/575 VAC) to an output voltage of 120 VAC (see "Accessories" on page 73). For dual gate applications, power has to be connected to each operator. Main power supply and control wiring MUST be run in separate conduits.

PBG*, CBG*, & IBG* Models Maximum Wire Length (Feet)							
AMERICAN WIRE GAUGE (AWG)	STANDARD OPERATOR + HEATER			3PHCONV KIT POWERING OPERATOR + HEATER + 1 AMP ON OUTLETS			
	120 VAC, 10.1 A (Includes fully loaded outlets)	120 VAC, 4 A	240 VAC, 2.4 A	208 VAC, 4.8 A	240 VAC, 4.2 A	480 VAC, 2.1 A	575 VAC, 1.7 A
14	100	250	800	360	470	1,900	2,800
12	150	400	1,300	570	750	3,000	4,500
10	250	600	2,100	910	1,200	4,800	7,100
8	400	1,000	3,300	1,400	1,900	7,600	11,000
6	600	1,500	5,300	2,300	3,000	12,000	18,000
4	1,000	2,500	8,400	3,700	4,800	19,000	28,500
Chart assumes: copper wire, 65°C, 5% drop							

Installation (continued)

All control wiring used to connect external devices to Class 2 circuits of the operator must be (QPTZ) Power-Limited Circuit Cables, Type CL2, CL2P, CL2R, or CL2X or other cable with equivalent or better electrical, mechanical, and flammability ratings.

IMPORTANT: The power wiring connector **MUST** be moved if input voltage is 240VAC (see step 5 below). Failure to do so will cause damage to the operator.

1. Turn off the AC power from the main power source circuit breaker.
2. Run the AC power wires to the operator.
3. Make sure the operator AC switch is in the OFF position. See the section below.
4. Open the junction box cover by loosening the top two screws and rotating the cover down.

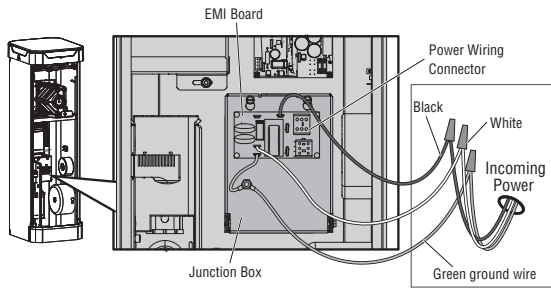

5. Locate the EMI Board and Power Wiring Connector, as shown in image.

120 VAC: Factory default is 120 VAC. Skip to 6.

240 VAC: Unplug the power wiring connector from the 120 VAC socket (factory default location) and plug it into the 240 VAC socket. This step is critical to not cause damage to the operator.

NOTE: Accessory outlets are disabled and cannot be used when powered by 240VAC.

208/240/480/575 VAC: See instructions for the Optional Transformer Kit Model 3PHCONV.

6. Connect the green ground wire to the incoming earth ground using a wire nut.
7. Connect the white wire to NEUTRAL using a wire nut.
8. Connect the black wire to HOT using a wire nut.
9. Replace the junction box cover. Ensure the wires are not pinched.
10. Turn on the AC power from the main power source circuit breaker.

AC POWER SWITCH

The AC switch on the operator turns the incoming 120/240 VAC power ON or OFF. The AC switch **ONLY** controls AC power to the operator and **DOES NOT** control battery power.

BATTERY SWITCH

The battery switch turns the battery power ON or OFF. Battery backup functionality is disabled if the battery switch is in the off position.

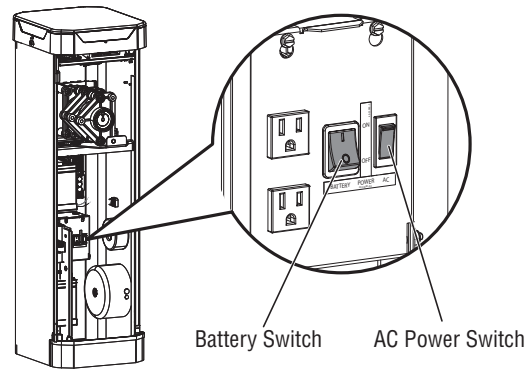

Installation (continued)

8 Connect Batteries

7AH BATTERIES (STANDARD)

The batteries are charged by the motor drive board. Charge power is provided by the system's transformer or by solar panels (optional).

1. Turn the AC power switch to OFF.
2. Turn the battery switch to OFF.
3. Connect a jumper between the positive (+) terminal of the battery to the negative terminal (-) of the other battery.
4. Connect the red battery wire from the operator to the positive (+) terminal of the battery.
5. Connect the black battery wire from the operator to the negative (-) terminal of the battery.
6. Turn the battery switch to ON.
7. Turn the AC power switch to ON to restore AC power.

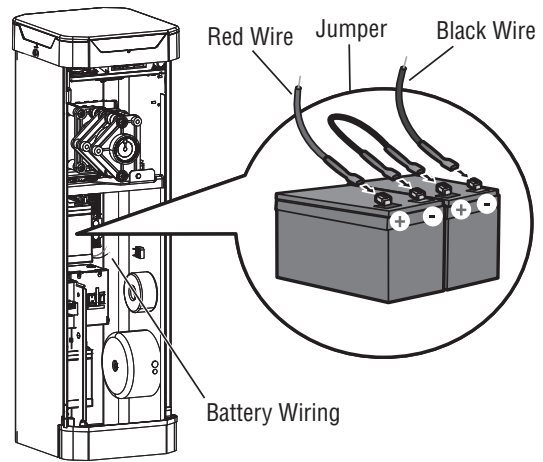

33AH BATTERIES

The batteries are charged by the motor drive board. Charge power is provided by the system's transformer or by solar panels (optional).

NOTE: The 33AH batteries (A12330SGLPK) requires battery harness (K41-0102-000) and battery tray (TRAY33AH) (see the Accessories section).

1. Turn the AC power switch to OFF.
2. Turn the battery switch to OFF.
3. Connect a jumper between the positive (+) terminal of the battery to the negative terminal (-) of the other battery.
4. Connect the (+) terminal of the battery to the red battery wire from the operator using the RED harness kit wire.
5. Connect the (-) terminal of the battery to the black battery wire from the operator using the BLACK harness kit wire.
6. Turn the battery switch to ON.
7. Turn the AC power switch to ON to restore AC power.

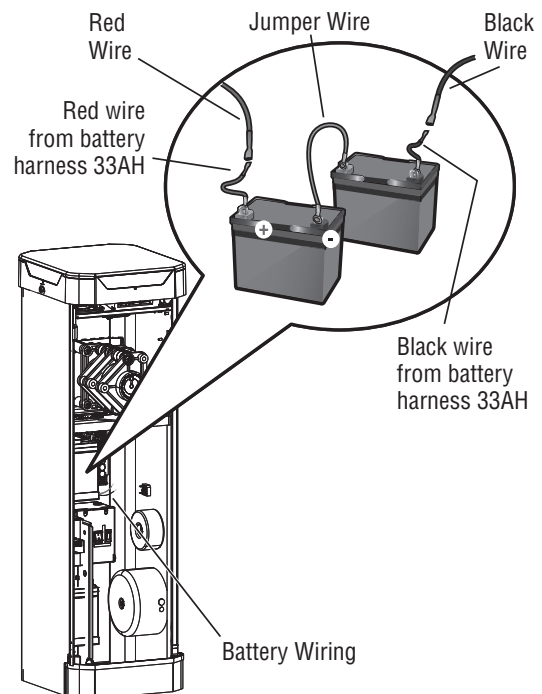

Installation (continued)

9 Install External Safety Devices

WIRE SAFETY DEVICES

There are three options for external safety devices depending on the specific device and how the device functions. Refer to the manual included with your device for more information. These device inputs are for monitored devices, which include pulsed photoelectric sensors, resistive edge sensors, and pulsed edge sensors. **Only one monitored safety device may be wired to each input.** Additional monitored safety devices may be wired to the expansion board.

NOTE: Board inputs for safety devices are yellow.

NOTE: Any monitored devices that are removed from the unit need to be unlearned in the menu under Monitored Eyes and Edges > Relearn All Monitored. Otherwise, the operator will not function.

MAIN CONTROL BOARD

CLOSE EYES/ MONITORED INTERRUPT AND COMMON

(2 Terminals) The CLOSE EYES/INTERRUPT input is for photoelectric sensor detection for the close direction. When an obstruction is sensed during barrier gate closing, the barrier gate opens to the full open position and resets the Timer-to-Close. This input is disregarded during barrier gate opening.

When connecting a non-monitored device as an interrupt, see INTERRUPT AND COMMON functionality under Step 10 Accessory Wiring.

CLOSE EDGE AND COMMON

(2 Terminals) The CLOSE EDGE input is for edge sensor detection for the close direction. When an obstruction is sensed during barrier gate closing, the barrier gate reverses to the full open position and resets the Timer-to-Close. This input is disregarded during barrier gate opening.

OPEN EYES/EDGE AND COMMON

(2 Terminals) The OPEN EYES/EDGE input is for photoelectric sensor or edge sensor detection for the open direction. When an obstruction is sensed during barrier gate opening, the barrier gate stops. This input is disregarded during barrier gate closing.

NOTE: Timer to close does not initiate as it only begins once Barrier arm reaches the full open position.

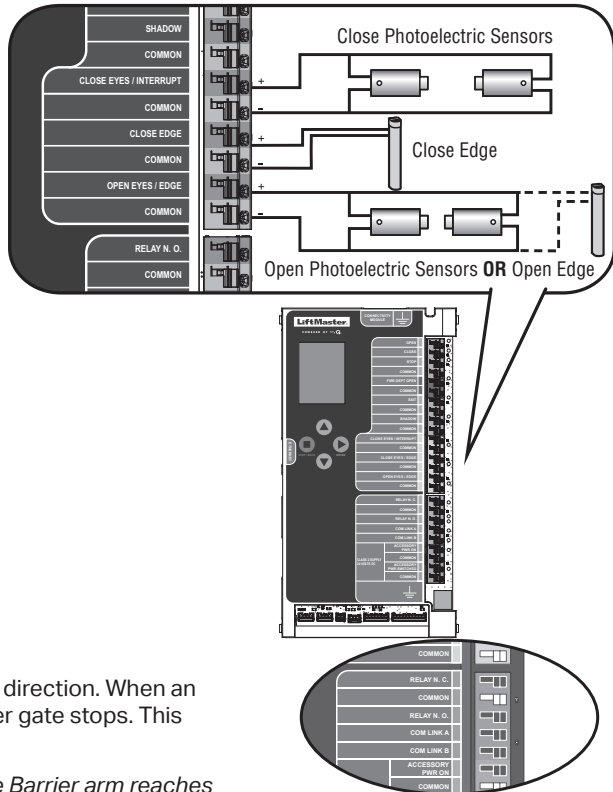

Installation (continued)

EXPANSION BOARD

EYE ONLY and COM: Open or Close Direction Photoelectric Sensors, the functionality is based on the switch settings (located next to the terminals).

- **Switch set to CLOSE:** Barrier gate reverses fully when an obstruction is sensed in the closing direction.
- **Switch set to OPEN:** Gate stops when an obstruction is sensed in the opening direction.

EYE/EDGE and COM: Open or Close Direction Photoelectric Sensors or Edge Sensor, the functionality is based on the switch settings (located next to the terminals).

- **Switch set to CLOSE:** Barrier gate reverses fully when an obstruction is sensed in the closing direction.
- **Switch set to OPEN:** Gate stops when an obstruction is sensed in the opening direction.

WIRELESS EDGE: Connection for wireless edge receiver.

NOTE: ONLY one wireless edge receiver may be connected to an operator. Up to 4 wireless edge transmitters LMWEXU may be programmed to the receiver.

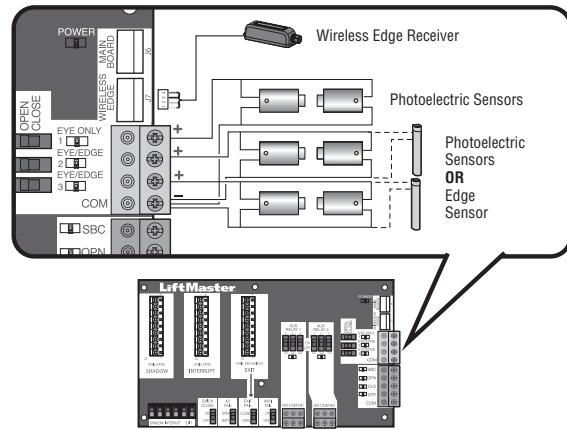

10 Accessory Wiring

ACCESSORY WIRING

All control wiring used to connect external devices to Class 2 circuits of the operator must be (QPTZ) Power-Limited Circuit Cables, Type CL2, CL2P, CL2R, or CL2X or other cable with equivalent or better electrical, mechanical, and flammability ratings.

EXTERNAL CONTROL DEVICES

EXIT AND COMMON

This input is a soft open command (maintained switch does not override external safeties). Used for exit probe, telephone entry, external exit loop detector, or any device that would command the gate to open.

- Opens a closed or closing gate and holds open an open gate, if maintained, reset Timer-to-Close at OPEN limit.

SHADOW AND COMMON

This input is used for external shadow loop detector when loop is positioned under the swing of the gate.

- Holds open gate at open limit.
- Only active when the gate is at the OPEN limit, disregarded at all other times.
- Reset Timer-to-Close at OPEN limit.

INTERRUPT AND COMMON

This input is used for an external interrupt loop detector when loop is on the outside of the gate.

- Holds open gate at open limit.
- Stops and reverses a closing gate to open limit.
- Reset Timer-to-Close at OPEN limit, activates quick close and anti-tailgate features when enabled on the expansion board.

NOTE: CLOSE LOOP INPUT WHEN QUICK CLOSE FROM EXPANSION BOARD SET TO ON

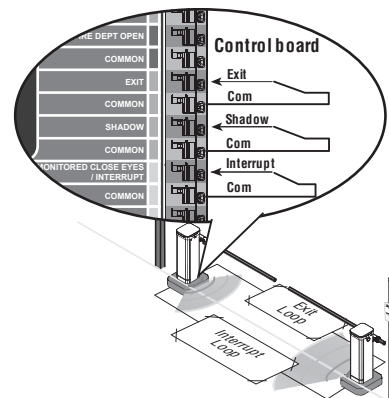
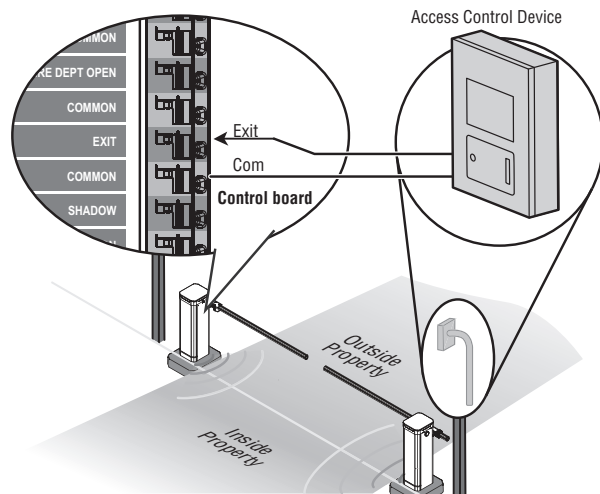

Installation (continued)

MISCELLANEOUS WIRING

Three Button Control Station (4 Terminals)

ATTENTION: These terminals are intended to be used with line-of-sight control devices ONLY.

- **OPEN and COMMON:** Opens a closed gate. Hard open (maintained switch overrides external safeties). If maintained, pauses Timer-to-Close at OPEN limit. Opens a closing gate and holds open an open gate (within line-of-sight). Reset Timer-To-Close at OPEN limit if canceled by Stop command.
- **CLOSE and COMMON:** Closes an open gate. Hard close (maintained switch overrides external safeties within line-of-sight)
- **STOP and COMMON:** Stops a moving gate. Hard stop (maintained switch overrides Open and Close commands). Cancels Timer-to-Close at OPEN limit. Overrides Open and Close commands (within line-of-sight).

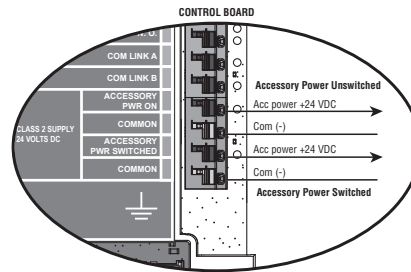
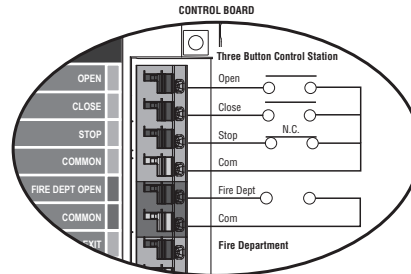

Fire Department Input (2 Terminals)

- **FIRE DEPT OPEN AND COMMON:** Opens a gate from any position. Hard open (maintained switch overrides external safeties). If maintained, reset Timer-to-Close at OPEN limit. Opens a closing gate and holds open an open gate (within line-of-sight).

Accessory Power (4 Terminals)

Power Class 2 Supply 24 VDC, MAX 1 AMP

- **ACCESSORY PWR SWITCHED AND COMMON:** Switched ON with gate motion and at the open limit when Timer-to-Close is active. Turns off 5 seconds after motion.
- **ACCESSORY PWR ON AND COMMON:** 24 VDC voltage out to power accessories, always ON.

MAIN CONTROL BOARD AUXILIARY RELAY

The main control board provides Normally Open (N.O.) and Normally Closed (N.C.) relay contracts to control external devices for connection of Class 2, low voltage (42 VDC (34 VAC) max 5 Amps) power sources only.

To set the function of the Main Control Board Relay:

1. Navigate to the display menu "Relay Configuration > Main Board Relay"
2. Press Up/Down navigation buttons to select the relay function.
3. Press the Enter button to confirm.

Function	Description
Off	Relay is always off (default).
SAMS	For use with SAMS configuration, requires setup in Operator Pairing menu. See SAMS operation setup.
Shadow Loop State	Energizes when Shadow input is active.
Interrupt Loop State	Energizes when an Interrupt input is active.
Opening	Energizes when gate is opening.
Closing	Energizes when gate is closing.
Up	Energizes when gate is opening or open.
Down	Energizes when gate is closing or closed.
Active Error	Energizes when an error code is active that prevents gate from moving. Fault must be cleared in the maintenance menu to de-energize.

Installation (continued)

⚠ CAUTION

- To AVOID damaging the circuit board, relays or accessories, DO NOT connect more than 42 VDC (32 VAC) to the AUX relay contact terminal blocks.

EXPANSION AND RELAY ADAPTER BOARDS OVERVIEW

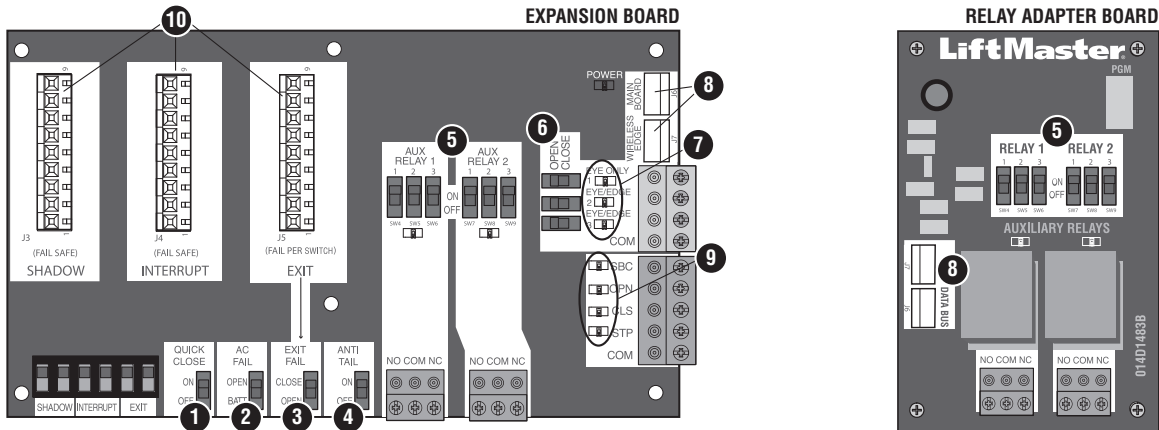

1. **Quick Close Switch/Circuit (QCC):**
 - OFF: No change to the gate's normal operation.
 - ON: Designed to be used with a loop connected to interrupt board input. Acts as a close loop when using Quick Close Switch. Ignores Timer-to-Close.
 - When installing close loop, using interrupt input with QCC ON, gate closes after interrupt input is released.

Note: Multi-Vehicle Tracking is enabled, the behavior of the QUICK CLOSE switch is ignored.
2. **AC FAIL switch:**
 - OPEN: Loss of AC power causes the gate to open approximately 15 seconds after AC power fail and remain OPEN until AC power is restored (enabling the Timer-to-Close).
 - BATT: With loss of AC power, gate remains in present position and operator is powered from batteries.
3. **EXIT FAIL switch:** When set to OPEN, if the EXIT plug-in loop detector (Model LOOPDETLM) detects a fault, then the gate opens and remains open until fault is cleared. When set to CLOSE, then plug-in EXIT loop detector faults are ignored (EXIT loop is faulted and inoperative).
4. **ANTI-TAIL switch:**
 - OFF: When Interrupt loop is activated, it causes a closing gate to stop and reverse.
 - ON: When Interrupt loop is activated, it causes a closing gate to pause. Once the vehicle is clear, the gate continues to close.
5. **AUX RELAY switches:** Set the AUX RELAY switches as needed to obtain the desired function as shown on the following page.
6. **EYE/EDGE switches:** Set the EYE/EDGE switches as needed to obtain the desired OPEN or CLOSE functionality.
7. **1, 2, and 3 LEDs:** LEDs indicating the status of the EYE/EDGE inputs. Also used to check the firmware version of the expansion board:
 - a. Locate the 1, 2, and 3 LEDs on the expansion board.
 - b. Disconnect AC/DC power to the main control board for 15 seconds.
 - c. Connect power. The 1, 2, and 3 LEDs flash in sequence until the main control board firmware revision is displayed. When the green POWER LED glows solid the LED 1 flashes the version number, then stops, then the LED 2 flashes the revision number. (For example: For version 5.1 when the green POWER LED is solid the LED 1 flashes 5 times, then stop, then the LED 2 flashes once).
8. **J6 and J7 inputs:** Communication bus connects the main control board, expansion board, or relay adapter board. Also connects LiftMaster wireless edge receiver LMWEKITU.

NOTE: ONLY one wireless edge receiver may be connected to an operator. Up to 4 wireless edge transmitters LMWETXU may be programmed to the receiver.
9. **Input LEDs:** LEDs indicating the active status of the SBC, OPN, CLS, and STP inputs.
10. **Loop detector inputs:** Inputs for the Plug-In Loop Detectors (Model LOOPDETLM).

Installation (continued)

AUXILIARY RELAYS

The expansion board and relay adapter board provide Normally Open (N.O.) and Normally Closed (N.C.) relay contacts to control external devices, for connection of Class 2, low voltage (42 VDC [34 VAC] max 5 Amps) power sources only. Function of relay contact activation determined by switch settings.

AUX Relay Setting	Switch Settings			AUX Relay 1	AUX Relay 2
	1	2	3		
Off	OFF	OFF	OFF	Relays off (default).	
Open Limit Switch	OFF	OFF	ON	Energizes at open limit.	
Not Closed	OFF	ON	OFF	Energizes when not at close limit.	
Gate Motion	OFF	ON	ON	Energizes when motor is on (gate in motion). For an additional audible or visual display, connect an external alarm or light (low voltage).	
Software Control	ON	OFF	OFF	Functionality depends on setting in display menu, see below.	
Power	ON	ON	OFF	Energizes when AC power or solar power is present.	

SOFTWARE CONTROL

If the AUX Relay Switch Setting is set to Software Control, the AUX Relay software function can be set:

1. Navigate to the display menu "Relay Configuration > Relay > Enter"
2. Press Up/Down navigation buttons to select the relay function.
3. Press the Enter button to confirm.
4. Confirm that the switches for the relay are set correctly.

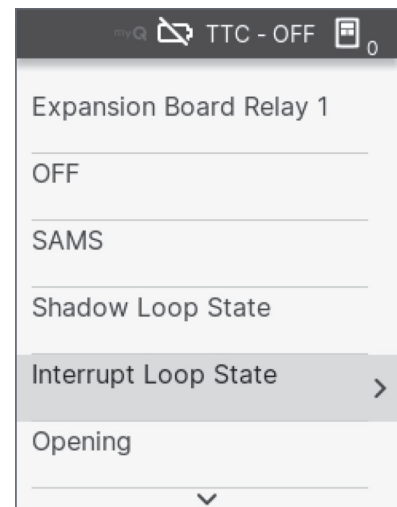
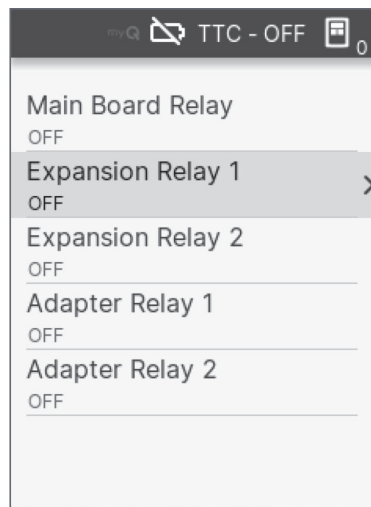
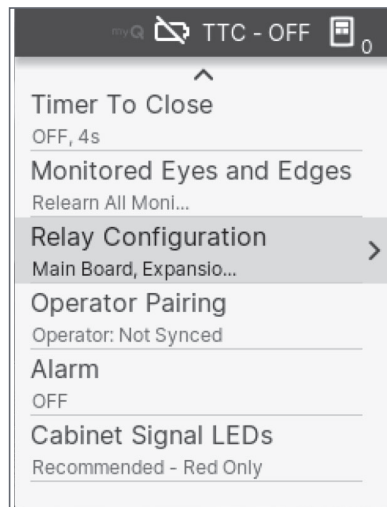

Installation (continued)

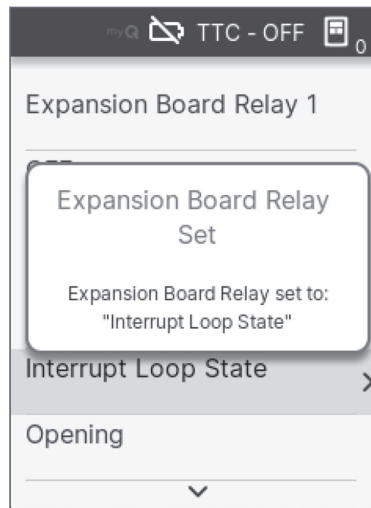
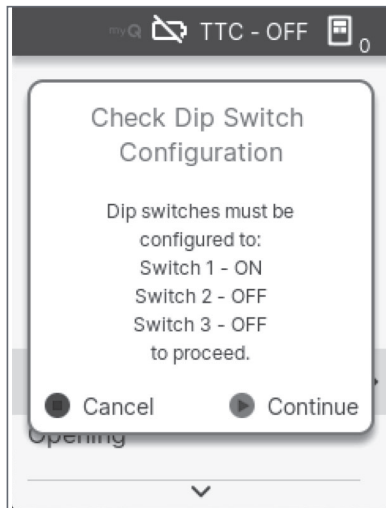

Function	Description
Off	Relay is always off (default for AUX Relay 2).
SAMS	For use with SAMS configuration, requires setup in Operator Pairing menu. See SAMS operation setup. (default for AUX Relay 1).
Shadow Loop State	Energizes when a Shadow input is active.
Interrupt Loop State	Energizes when an Interrupt input is active.
Opening	Energizes when gate is opening.
Closing	Energizes when gate is closing.
Up	Energizes when gate is opening or open.
Down	Energizes when gate is closing or closed.
Active Error	Energizes when an error code is active that prevents gate from moving.

Installation (continued)

LED RELAY LIGHT ADJUSTMENTS

RED/GREEN LIGHT FUNCTIONALITY						
Red light wired to AUX RELAY 1. Green light wired to AUX RELAY 2.						
GATE STATE	AUX RELAY 1 SWITCHES			AUX RELAY 2 SWITCHES		
	1 OFF	2 OFF	3 OFF	1 ON	2 ON	3 ON
Closed	Red light OFF*			Green light OFF		
Opening	Red light ON/Flash			Green light OFF		
Open	Red light OFF			Green light ON		
Closing	Red light ON/Flash			Green light OFF		
Defined Mid Stop	N/A			N/A		
Undefined Mid Stop	Red light ON			Green light OFF		
Timer more than 5 seconds	Red light OFF			Green light ON		
Timer less than 5 seconds	Red light ON/Flash			Green light OFF		

* For red light ON when gate is closed, set switch 1 on AUX RELAY 1 to ON

Note: This setting does not put AUX Relay 1 in Software Control (R1: ON-OFF-OFF and R2: ON-ON-ON).

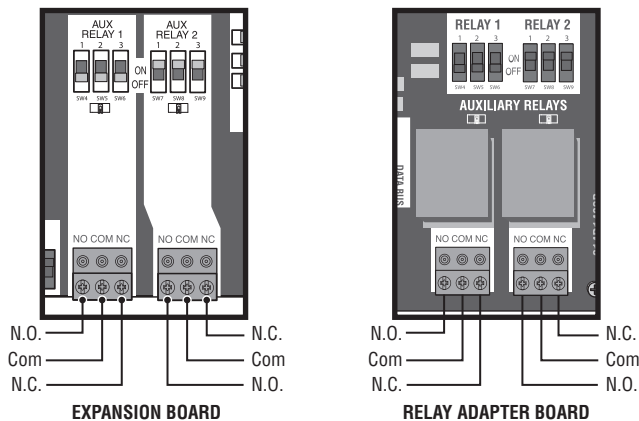
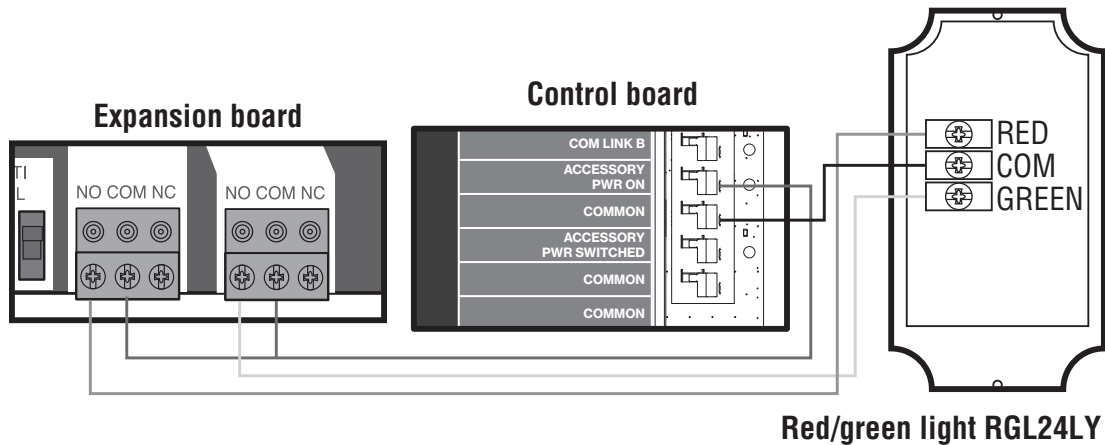

Installation (continued)

WIRING ACCESSORIES TO THE EXPANSION BOARD

Refer to the chart below and the corresponding image for a description of the expansion board inputs.

1	Wireless edge, main control board, or relay adapter board	Connection for wireless edge receiver, main control board, or relay adapter board. NOTE: <i>ONLY one wireless edge receiver may be connected to an operator. Up to 4 wireless edge transmitters LMWETXU may be programmed to the receiver.</i>
2	Safety Device Inputs (4 terminals total), Open or Close Direction based on switch setting next to inputs	EYES ONLY Input: Open or Close Direction Photoelectric Sensors, Close: reverses fully, Open: stops. EYES/EDGE Input(s): Open or Close Direction Photoelectric Sensors, Infra-red detector wired or Edge Sensor, Close: reverses fully, Open: stops.
3	Single Button Control, SBC (2 terminals)	Gate command sequence - Open, Stop, Close, Stop, Open, Stop, Close, (auto-reverse) open (maintained switch does not override external safeties).
4	Open Input (& common) (3-Button Control Station, 4 terminals total)	Open command - opens a closed gate. <ul style="list-style-type: none"> • Soft open (maintained switch does not override external safeties). • If maintained, pauses Timer-to-Close at OPEN limit. • Opens a closing gate and holds open an open gate.
5	Close Input (& common) (3-Button Control Station, 4 terminals total)	<ul style="list-style-type: none"> • Close command - closes an open gate. • Soft close (maintained switch does not override external safeties).
6	Stop Input (& common) (3-PB station, 4 terminals total)	Stop command - stops a moving gate. <ul style="list-style-type: none"> • Hard stop (maintained switch overrides Open and Close commands) • Cancels Timer-to-Close at OPEN limit. • Overrides an Open or Close command
7	Exit Loop Input (2 terminals)	Loop wire connection for plug-in loop detector when loop is inside secured area near gate. Open command - opens a closed gate. <ul style="list-style-type: none"> • Soft open (maintained switch does not override external safeties) • If maintained, reset Timer-to-Close at OPEN limit. • Opens a closing gate and holds open an open gate.
8	Shadow Loop Input (2 terminals)	Loop wire connection for plug-in loop detector when loop is positioned under the gate. <ul style="list-style-type: none"> • Holds open gate at open limit • Disregarded during gate motion • Reset Timer-to-Close at Open Limit
9	Interrupt Loop (2 terminals), also Close Loop (QCC ON)	Loop wire connection for plug-in loop detector when loop is along the side of the gate. <ul style="list-style-type: none"> • Holds open gate at open limit • Stops and reverses a closing gate • Reset Timer-to-Close at Open Limit • When Quick Close Circuit (QCC) is set to ON, closes gate once interrupt command is released.

Installation (continued)

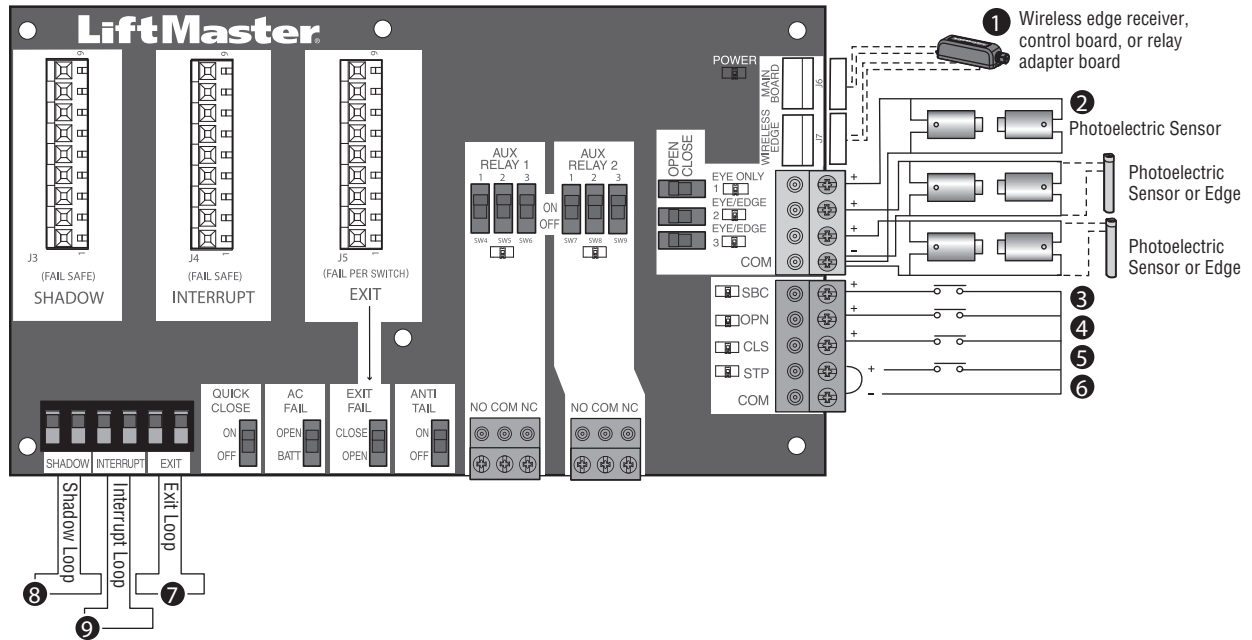

Installation (continued)

11 Main Control Board Overview

Open the top lid to access the main control board, LCD display, and navigation buttons.

NOTE: Avoid servicing the operator, main control board, motor board, and electronics during rain to avoid damage from water.

1. **LCD Display:** The LCD display presents a navigational menu system which allows for operator configuration, information, status, and diagnostics.
2. **NAVIGATION BUTTONS:** Up and down arrows allow scrolling, and arrow for an "enter" function, and a stop to back out of a menu.
 - To enter the menu, use the button with the green arrow as the "enter" function, the up and down arrows to scroll, and the red button with the stop symbol to back out of the menu.
 - The up and down arrows can be used to open or close the gate after limits have been set.
3. **STATUS LEDs:** The STATUS LEDs indicate the status of the operator.

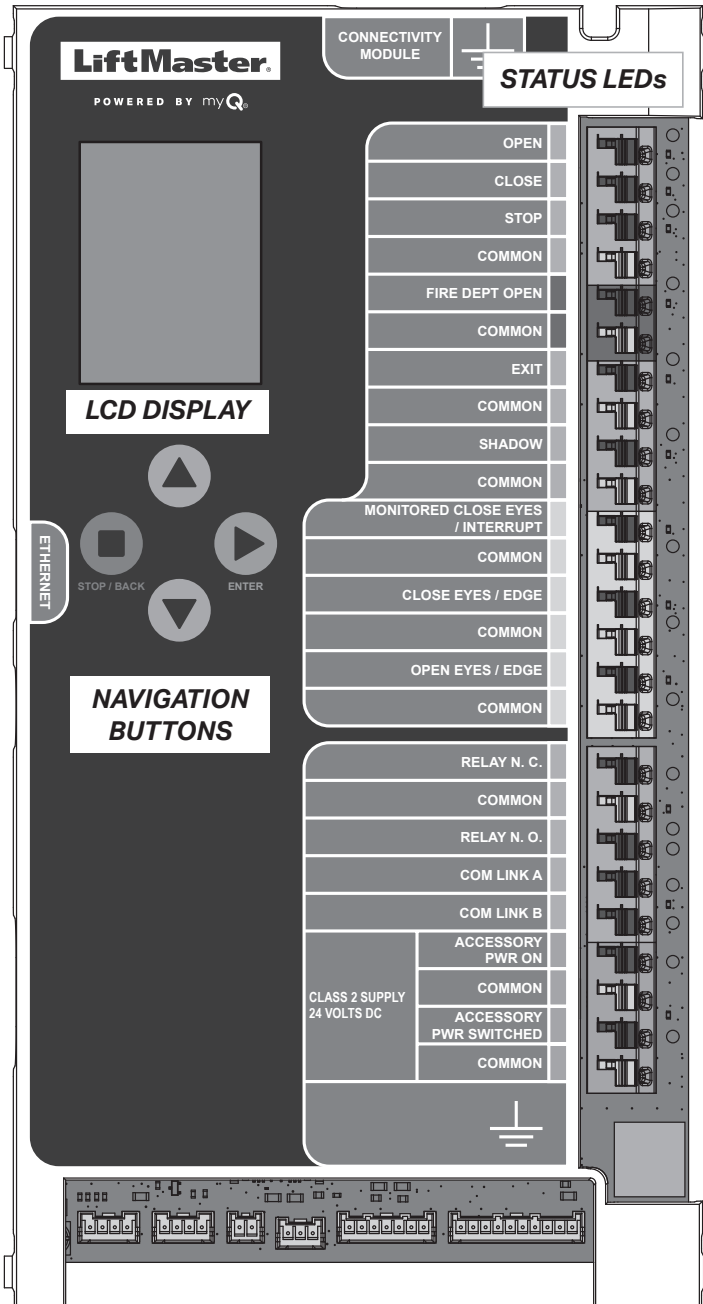







Control Board LEDs

Input LEDs		
OPEN, CLOSE, STOP INPUT	OFF	Input inactive
	ON	Input active
	BLINK	Input active on other operator or expansion board If maintained, pauses Timer-to-Close at OPEN limit.
FIRE DEPT INPUT	OFF	Input inactive
	ON	Input active
	BLINK	Input active on other operator or hold active due to power failure
EXIT	OFF	Input inactive
	ON	Input active
	BLINK	Input active on other operator
SHADOW	OFF	Input inactive
	ON	Input active
	BLINK	Input active on other operator
MONITORED CLOSE EYES/ INTERRUPT	OFF	Input inactive
	ON	Input active
	BLINK	Input active on other operator
CLOSE EYES/ EDGE	OFF	Input inactive
	ON	Input active
	BLINK	Input error, active on other operator, or wireless edge error
OPEN EYES/ EDGE	OFF	Input inactive
	ON	Input active
	BLINK	Input error, active on other operator, or wireless edge error













Installation (continued)

DISPLAY ICONS

Icon	Icon States	Description
 myQ		The operator is connected to the myQ service.
Ethernet		Ethernet is enabled and the operator can access the Internet.
		Ethernet is enabled, but the operator cannot access the Internet. Provide the operator with an Ethernet network connection with access to the Internet. Enable and configure the Ethernet connection using the operator's LCD menu and operator's Wi-Fi access point page.
	No Ethernet Icon	Ethernet connection is disabled on the LCD menu. OR Ethernet connection is not currently in use. Provide the operator with an Ethernet network connection with access to the Internet. Enable and configure the Ethernet connection using the operator's LCD menu and operator's Wi-Fi access point page.

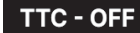
 Wi-Fi		Wi-Fi is enabled and the operator can access the Internet. Curved bars represent signal strength. The lower the bars, the weaker the Wi-Fi connection. Check antenna installation and Wi-Fi host access point to improve signal strength.
		Wi-Fi is enabled, but the operator cannot access the Internet. Provide the operator with a Wi-Fi network connection using a valid SSID and password for the operator Wi-Fi to access the Internet. Enable and configure the Wi-Fi connection using the operator's LCD menu and operator's Wi-Fi access point page.
	No Wi-Fi Icon	Wi-Fi connection is disabled on the LCD menu. OR Wi-Fi connection is not currently in use. Provide the operator with a Wi-Fi network connection using a valid SSID and password for the operator Wi-Fi to access the Internet. Enable and configure the Wi-Fi connection using the operator's LCD menu and operator's Wi-Fi access point page.

Installation (continued)

Icon	Icon States	Description
 Battery		Battery is charging.
		Battery is fully charged and is maintained on a float charge.
		Operator running on battery power only. Check the operator AC Power Switch is in the ON position.
		Battery is critically low. Battery is not being charged. The operator is not able to move the barrier gate arm when the battery is critically low. The position of the barrier gate arm will remain in the position according to the setting on the Low Battery Menu Setting.
		No battery detected. Check battery and connections. Check the operator Battery Switch is in the ON position.
 Time-to-Close		Timer-to-Close is ON and set to a value. Example shows 10 seconds.
		Timer-to-Close is OFF.
 Remote Control Transmitters		The operator has not learned any remote control transmitters.
		Example: The operator has learned 12 remote control transmitters.

Adjustment

Limit, Speed, and Force Adjustment



WARNING

To reduce the risk of SEVERE INJURY or DEATH:

- NEVER increase force beyond minimum amount required to move barrier arm.
- NEVER use force adjustments to compensate for a binding or sticking barrier arm.
- If one control (force, speed or travel limits) is adjusted, the other controls may also need adjustment.
- After ANY adjustments are made, the reversal system MUST be tested. Barrier arm MUST reverse on contact with an object.
- Faster barrier arm speed increases risk to pedestrians. Use minimum speed necessary to move barrier arm.

INTRODUCTION

Your operator is designed with an LCD menu to make travel limit and force adjustments easy. The adjustments allow you to program where the barrier arm will stop in the open and close position.

After the limits are programmed via the LCD menu, the force may also be fine-tuned using the LCD Menu. The limits can be set using the main control board (below).

SET ARM LENGTH

On the LCD menu, navigate to "Arm Length > Enter".

1. Press the Up/Down navigation buttons to select the length of the arm.
2. Press the Enter button to confirm.

SET THE LIMITS

For dual gate applications the limits have to be set for each operator. The barrier arm MUST be attached to the operator before setting the limits and force.

Note: Operator must move the arm a certain distance in order to accurately read a limit location. Be sure to move the arm prior to attempting to save a limit

1. On the LCD Menu, navigate to "Limit Learn".
2. Select Right Hand, or Left Hand (refer to the image below to determine arm direction).
3. **Check spring module orientation. If right handed, spring module arrows will point right. If left handed, spring module arrows will point left. The arm in the closed position should match the spring direction.**
4. **Check that arm is installed and in the vertical (open) position prior to adding tension to springs.**
5. Press the Up/Down navigation buttons to move the arm to the Open Limit.
6. Select the Confirm menu item to set the Open Limit.
7. On the LCD Menu, navigate to "Limit Learn > Set Lower > Enter".
8. Press the Up/Down navigation buttons to move the arm to the Close Limit.
9. Select the Confirm menu item to set the Close Limit.

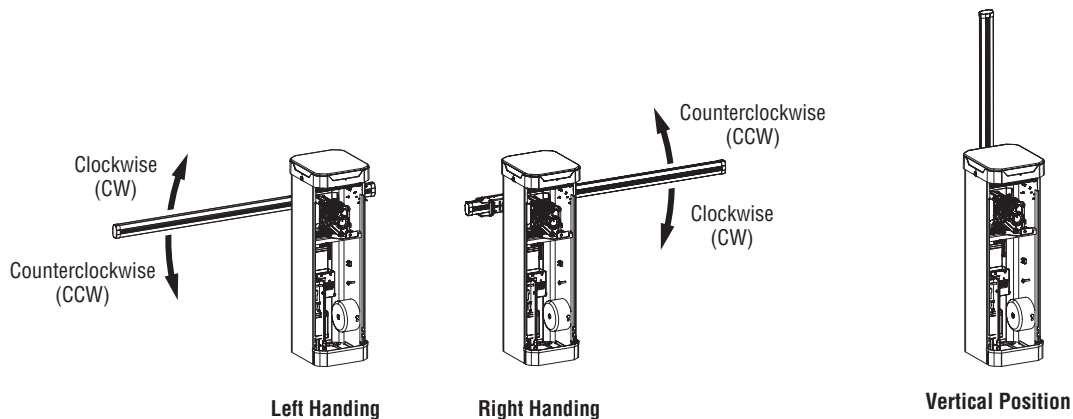
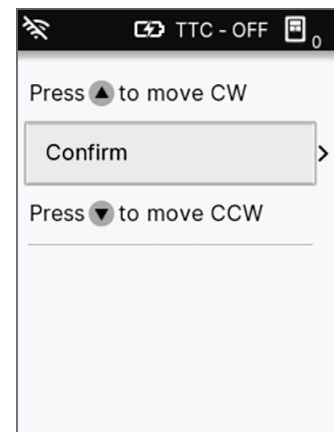
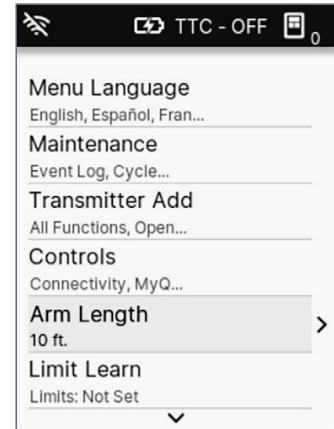

Note: inside the property looking out

Adjustment (continued)

SPEED CONTROL

Open / Close Speed	PBG24DCW, PBG24DCG Maximum 12 feet Arm Length	CBG24DCW, CBG24DCG Maximum 14 feet Arm Length	IBG24DCW, IBG24DCG Maximum 24 feet Arm Length
Fast Speed	1.9 seconds	2.5 seconds	6.0 seconds
Medium Speed	~ 3.0 seconds	~ 3.75 seconds	~ 7.0 seconds
Slow Speed (Default)	~ 4.0 seconds	~ 5.0 seconds	~ 8.0 seconds

The operator's Open / Close speed is preset to Slow Speed from the factory.

- To adjust the speed, on the LCD Menu, navigate to Arm Speed to Increase or Decrease between Fast, Medium, or Slow.
- Set the Arm Length to match the length of the installed arm by navigating the LCD Menu to Arm Length.

For a Tandem Gate setup, use the same barrier arm speed setting for both operators.

After any speed adjustment:

- After any speed adjustment, perform the Obstruction Test. See "Obstruction Test" on page 38.

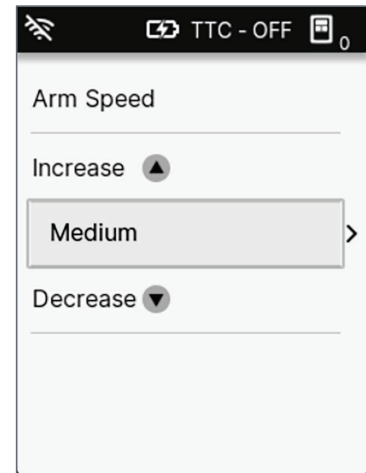

FINE TUNE THE FORCE

Once the initial limits have been set, the FORCE in the menu is used for fine tuning the force where wind or environmental changes may affect the barrier arm travel. The FORCE is set to High at the factory. Based on the length and weight of the barrier arm, it may be necessary to make additional force adjustments. The force setting should be high enough that the barrier arm does not reverse by itself nor cause nuisance interruptions, but low enough to prevent serious injury to a person or serious damage to an object struck by the barrier arm. The force setting is the same for both the open and close barrier arm directions.

- Open and close the barrier arm with the up and down arrow buttons.
- If the barrier arm stops or reverses before reaching the fully open or closed position, increase the force setting in the LCD menu.
- Perform the "Obstruction Test" after every limit, speed, and force setting adjustment, see "Obstruction Test" on page 38.

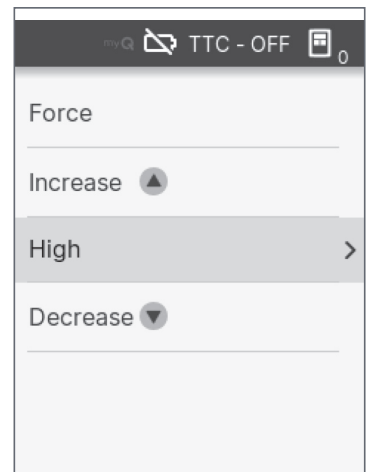

Adjustment (continued)

ADJUST THE LIMITS

After both limits are set and the operator is ready to run, one limit can be adjusted independently from the other by following steps 1-3 of "Set the Limits" on page 35.

After any limit adjustment:

1. After any limit adjustment, perform the Obstruction Test. See "Obstruction Test" on page 38 below.

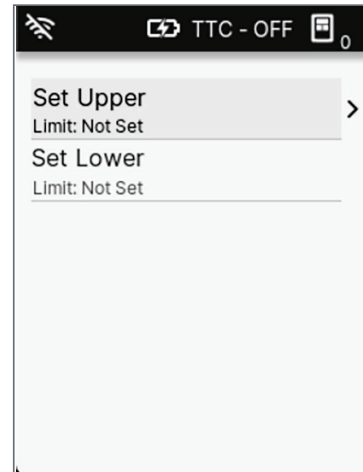

OBSTRUCTION TEST

The operator is equipped with an inherent (built in to the operator) obstruction sensing device. If the barrier arm encounters an obstruction during close motion, the operator reverses direction of the barrier arm to the open limit. The following procedure tests ONLY the inherent (built in to the operator) obstruction sensing device:

1. Open and close the barrier arm with the up and down arrow buttons, ensuring that the barrier arm is stopping at the proper open and close limit positions.
2. Either place an object between the open barrier arm and the ground or obstruct the barrier arm by hand. Make sure that any external safety devices, such as an edge or photoelectric sensor, is NOT activated by the object or by hand.

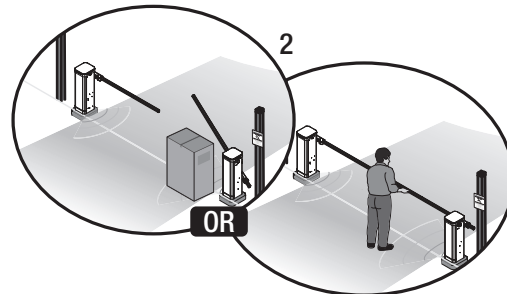

NOTE: If the system has trouble reversing refer to Step 6 "Install the Barrier Arm" for tightening the arm hub bolts to **60 ft-lb** torque spec. If arm hub bolts are not properly tightened to spec, the system may not be able to reverse adequately.

3. Run the barrier arm in the close direction. The barrier arm should stop and reverse upon contact with the object or hand. If the barrier arm does not reverse, reduce the force setting. The barrier arm should have enough force to reach both the open and close limits, but it MUST reverse after contact with an object or hand.
4. Repeat the test for the open direction and for each operator. When obstruction is encountered in the open direction, the barrier arm will stop, it will not reverse.

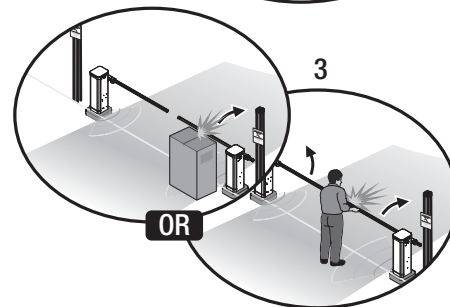

ALWAYS PERFORM THE OBSTRUCTION TEST AFTER ANY ADJUSTMENTS ARE MADE TO THE OPERATOR SYSTEM.

Adjustment (continued)

LED ADJUSTMENTS

CABINET SIGNAL and ARM SIGNAL LED SETTING OPTIONS:

The Cabinet Signal LEDs and the Arm Signal LEDs can be set independently to separate settings.

Cabinet Signal LED setting options selection:

1. On the LCD Menu, navigate to "Cabinet Signal LEDs > Enter".
2. Navigate to highlight a setting option and select using Enter.

Arm Signal LED setting options selection:

1. On the LCD Menu, navigate to "Arm Signal LEDs > Enter".
2. Navigate to highlight a setting option and select using Enter.

Cabinet LED Setting	Behavior on OPEN	Behavior IN MOTION (between limits)	Behavior on CLOSE
RED ONLY	OFF	Flashing RED	Solid RED
GREEN ON OPEN	Solid GREEN	Flashing RED	Solid RED
OFF	OFF	OFF	OFF

Arm LED Setting	Behavior on OPEN	Behavior IN MOTION (between limits)	Behavior on CLOSE
OFF (Default)	OFF	OFF	OFF
RED ONLY	OFF	Flashing RED	Solid RED
GREEN ON OPEN	Solid GREEN	Flashing RED	Solid RED

Configuration

1 Operator Configuration

The operator can be setup to support the following scenarios.

- Tandem Setup-Wireless: See "Tandem Wireless Setup" on page 40.
- Tandem Setup-COM Link: See "COM Link Tandem-Setup" on page 42.
- SAMS (Sequence Access Management System): See "SAMS Wiring with Relays Not Energized" on page 44.
- Two-Way Traffic: See "Two-Way Traffic Mode" on page 46.
- Trap/Sequential Merge: See "Trap/Sequential Merge Operator Sync Mode" on page 47.

NOTE: For dual gate applications, each operator must have its own Internet network connection (Ethernet or Wi-Fi) to allow each operator to receive firmware updates.

TANDEM SETUP

There are two options for tandem communication: COM Link or wireless. Follow the directions according to your application. Do not use COM Link and wireless communication simultaneously. Use only the same operator models in a tandem gate setup. COM Link communication is recommended for better response and battery standby performance over wireless.

NOTE: If one operator in the pair becomes inoperable, the remaining operational unit can be commanded by inputs wired directly to the unit or wireless devices learned to that unit. Inputs/devices wired or learned to the inoperable unit will be ignored.

Tandem Wireless Setup

1. Choose an operator to be the network primary operator. Program all wireless accessories to the primary operator except for any safety devices required for the second operator.

NOTE: We recommend that all accessories, except safety devices, and board configurations are set on the primary operator.

2. On primary operator, use the LCD Menu to navigate to Operator Pairing > Connection Type > Wireless > Enter. The LCD screen will display a message confirming the mode has been set to Wireless.

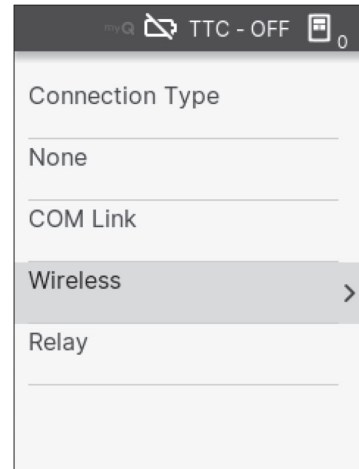

3. On the primary operator's LCD Menu, navigate to "Operator Pairing > Configure as Primary > Enter". The LCD screen displays a message that it is looking for the secondary operator to sync.

Continue to the secondary operator to complete the sync setup.

NOTE: The operator times out of programming mode after 180 seconds.

4. On secondary operator, use the LCD Menu to navigate to Operator Pairing > Connection Type > Wireless > Enter. The LCD screen will display a message confirming the mode has been set to Wireless.

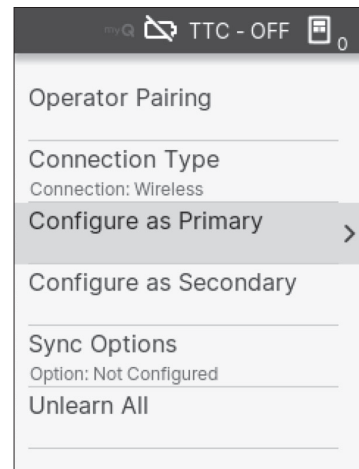

Configuration (continued)

5. On the secondary operator's LCD Menu, navigate to "Operator Pairing > Configure as Secondary > Enter". The LCD screen displays a message that it is looking for the primary operator to sync.
6. On the primary operator, check for the notification that the primary operator is synced with the secondary operator.

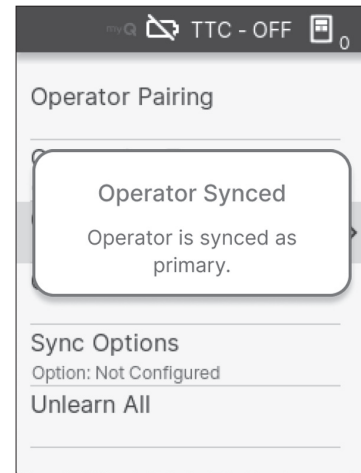

7. On the secondary operator, check for the notification that the secondary operator is synced with the primary operator.
8. On each operator, use the LCD Menu to navigate to Operator Pairing > Sync Options > TANDEM Configuration > Enter. The LCD screen will display a message confirming the option has been set to Tandem.

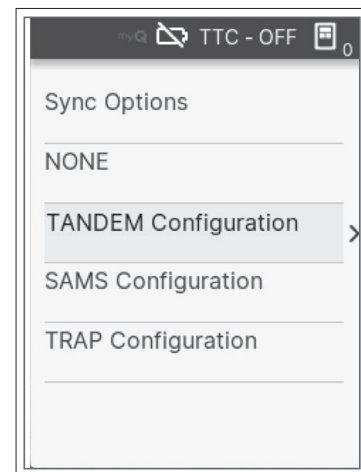

To deactivate the wireless feature:

1. On the LCD Menu for either operator, navigate to "Operator Pairing > Unlearn All > Enter".
2. Repeat the steps for the other operator.

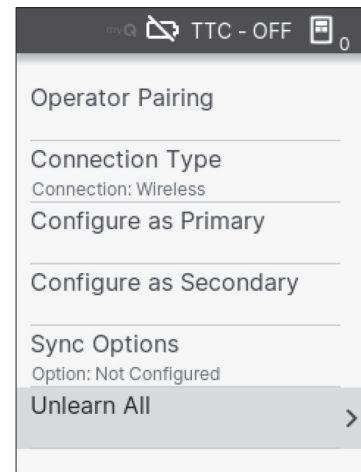

Configuration (continued)

COM Link Tandem Setup (Recommended)

Use only the same operator models in a tandem setup. Before digging, contact local underground utility locating companies. Use PVC conduit to prevent damage to cables.

TANDEM GATE WIRE TYPE (SHIELDED TWISTED PAIR CABLE)	
22AWG up to 200 feet (61 m)	18AWG - 200-1000 feet (61-305 m)
Wire must be rated at 30 Volt minimum.	

1. Disconnect ALL power to the operator and turn OFF the battery and AC power switches.
2. Trench across driveway to bury the shielded twisted pair cable.
3. Connect the wires from the shielded twisted pair cable to the COM Link terminals on the primary gate operator's main control board.

NOTE: We recommend that all accessories and board configurations are set on the primary operator.

4. Route the shielded twisted pair cable to the secondary gate operator's main control board.
5. Connect the wires from the shielded twisted pair cable to the COM Link terminals on the secondary operator's main control board (COM Link A to COM Link A and COM Link B to COM Link B). Ground the shield of the cable to the chassis ground of one operator.
6. Connect ALL power to the operator and turn ON the battery and AC power switches.
7. On primary operator, use the LCD Menu to navigate to Operator Pairing > Connection Type > COM Link > Enter. The LCD screen will display a message confirming the mode has been set to COM Link

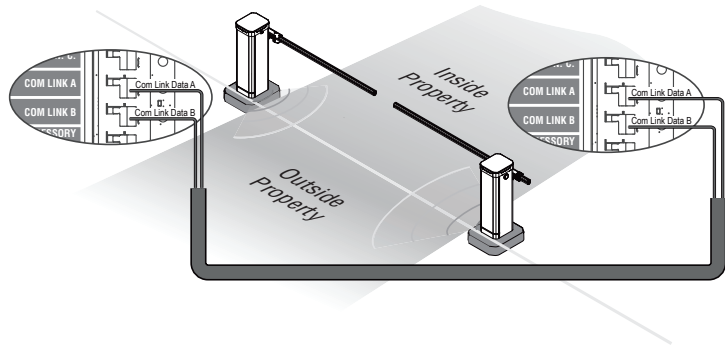

8. On primary operator, use the LCD Menu to navigate to Operator Pairing > Configure as Primary > Enter. The LCD screen will display a message indicating that it is looking for the secondary operator to sync.

Continue to the secondary operator to complete the sync setup.

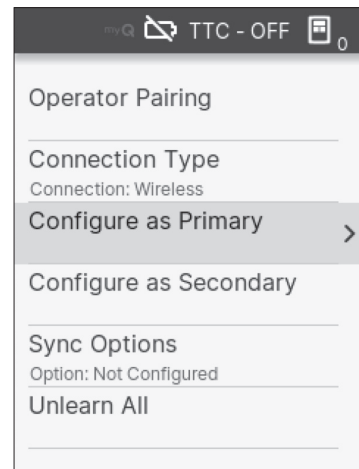
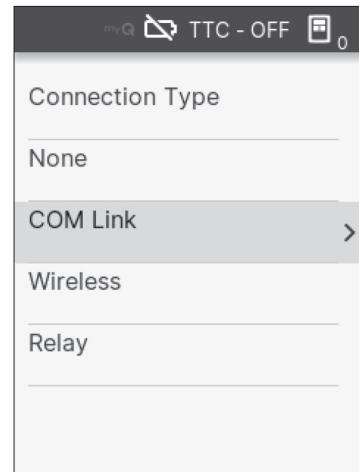

Configuration (continued)

9. On secondary operator, use the LCD Menu to navigate to Operator Pairing > Connection Type > COM Link > Enter. The LCD screen will display a message confirming the mode has been set to COM Link.
10. On secondary operator, use the LCD Menu to navigate to Operator Pairing > Configure as Secondary > Enter. The LCD screen will display a message indicating that it is looking for the primary operator to sync.
11. On each operator, check for the notification that the operator is synced.

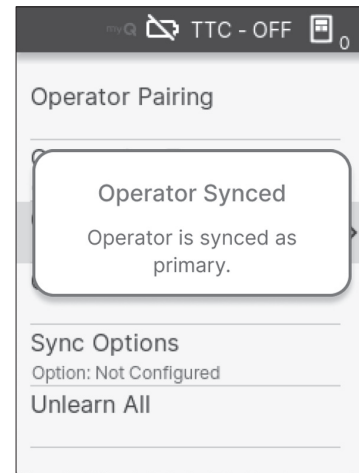

12. On each operator, use the LCD Menu to navigate to Operator Pairing > Sync Options > TANDEM Configuration > Enter. The LCD screen will display a message confirming the option has been set to Tandem.

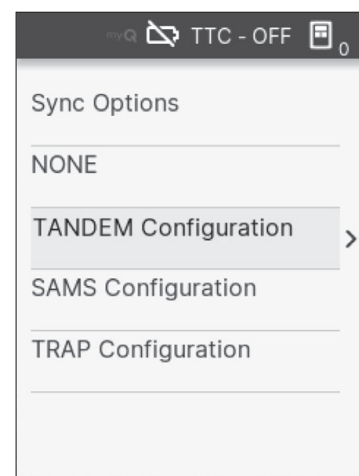

Configuration (continued)

SAMS (Sequence Access Management System) operation

To keep vehicles from rushing the Swing/Slide gate, the barrier arm stays in closed position until the Swing/Slide gate reaches fully open position then the barrier arm is released to open and allow vehicles to pass.

SETUP

Wire operators and set Aux Relay functions as per diagram below.

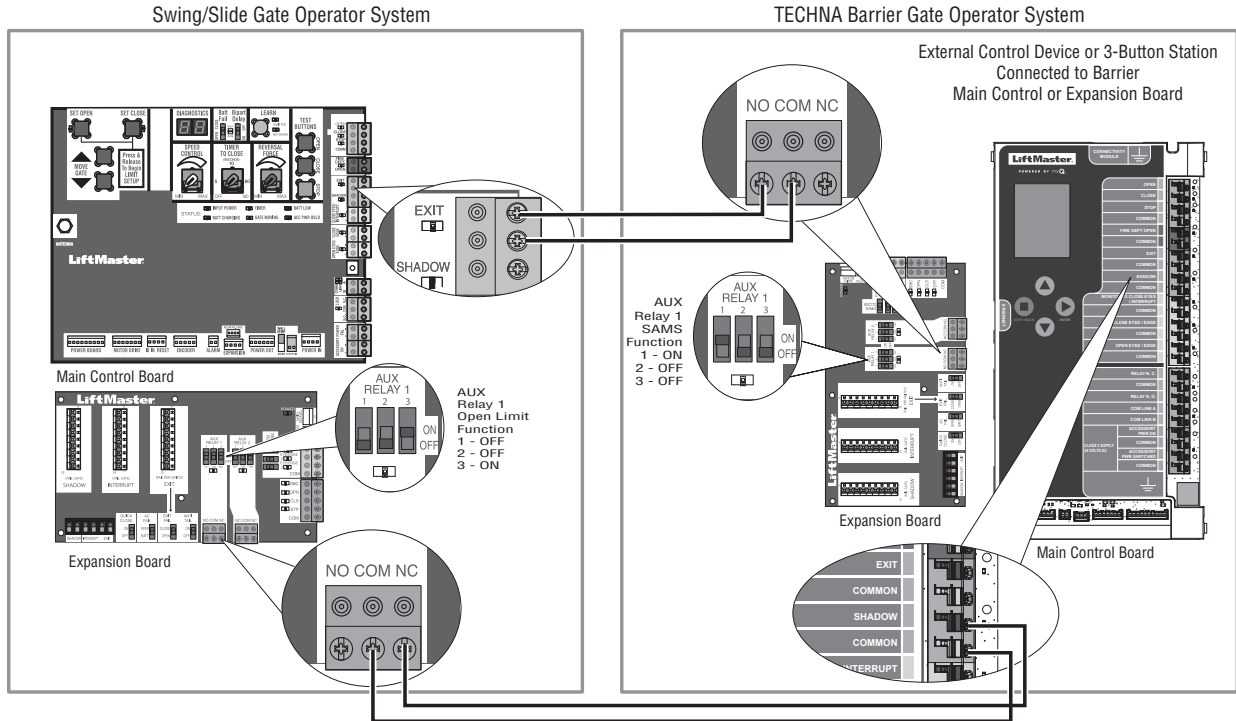

Configuration (continued)

ENABLE RELAY MODE / SAMS SYNC OPTION

On the LCD menu, navigate to "Operator Pairing > Mode > Relay > Enter". The LCD screen displays a confirmation of the change.

The Operator Pairing Sync Option is automatically set to SAMS - Pulse Only when mode is set to Relay.

Operator Pairing Sync Options selection:

1. On the LCD Menu, navigate to Operator Pairing > Sync Options > Enter.
2. Navigate to highlight a setting option and select using Enter.

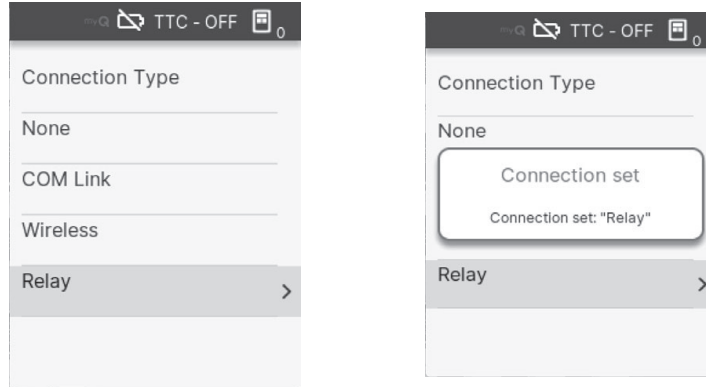

Option	Description
SAMS - Pulse Only	Expansion Board Auxiliary Relay 1 N.O. contact will pulse when an Open command is received.
SAMS - Pulse and Hold	Expansion Board Auxiliary Relay 1 N.O. contact will pulse when an Open command is received and will be held active while the barrier gate is not at the Closed Limit position.

Dual Gate Settings

Note: We recommend that all accessories, except safety devices, and board configurations are set on the primary operator.

MAIN CONTROL BOARD

Feature	Primary Operator	Secondary Operator
Timer-to-Close	Set the TTC in display menu	OFF
Speed	Set the speed control on each operator to the desired setting. Speed can be adjusted via display menu (see "Speed Control" on page 37 for more details).	
BATTERY Fail	Set each operator to the desired setting. Power Fail can be set via display menu.	

EXPANSION BOARD

Feature	Primary Operator	Secondary Operator
QUICK CLOSE	Set switch to desired setting on operator with interrupt loop connected.	
ANTI-TAIL	Set switch to desired setting on operator with interrupt loop connected.	
AC FAIL	Set switch on each operator to desired setting.	
EXIT FAIL	Set switch to desired setting on operator with exit loop connected.	

Configuration (continued)

TWO-WAY TRAFFIC MODE

- Two-way traffic mode provides the ability for traffic to enter and exit in the same lane.
- On vehicle entry, Exit Loop will not affect Timer-To-Close or initiate an Exit command until vehicle has passed.
- If vehicle does not pass Exit Loop within 10 seconds of the gate reaching the Closed position, the entry will time out and Exit Loop will return to normal functionality.
- To turn on Two-Way Traffic Mode, on the LCD menu, navigate to "Timer to Close > Two Way Traffic > Enter".
- Open (Main Control Board), Open (Expansion Board), or Exit (Main Board), Exit (Expansion Board) input must be used for Two-Way Traffic Mode entry commands.

NOTE: Transmitters are not recommended to be used with Two-Way Traffic Mode.

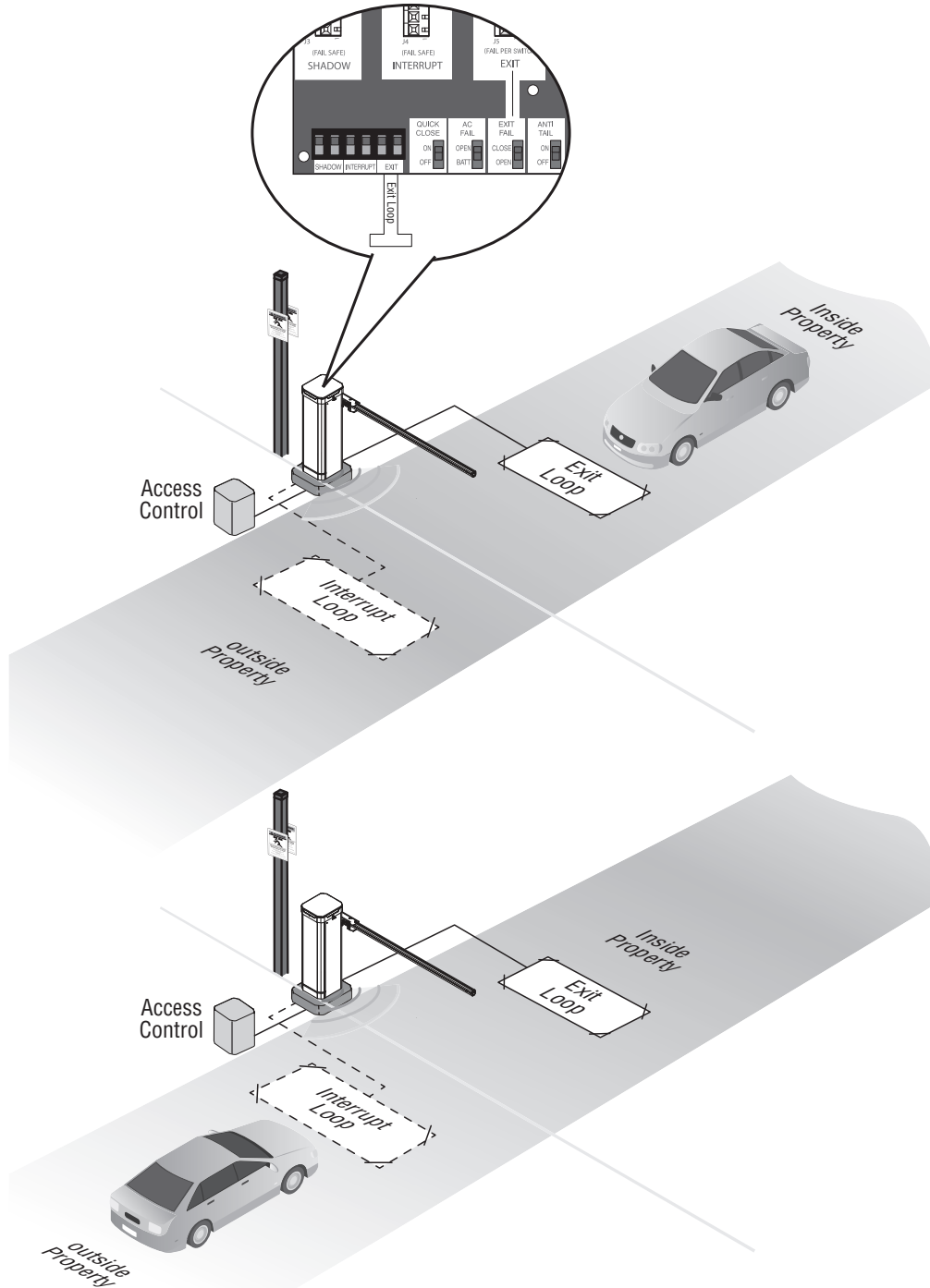

Configuration (continued)

Trap/Sequential Merge Operator Sync Mode

- Trap/Sequential Merge Operator Sync Mode will delay opening of a gate until the other paired gate operator is closed.
- To turn on Trap/Sequential Merge Operator Sync Mode after Operator Pairing is complete, on the LCD menu, navigate to "Operator Pairing > Sync Options > TRAP Configuration > Enter".

TRAP CONFIGURATION

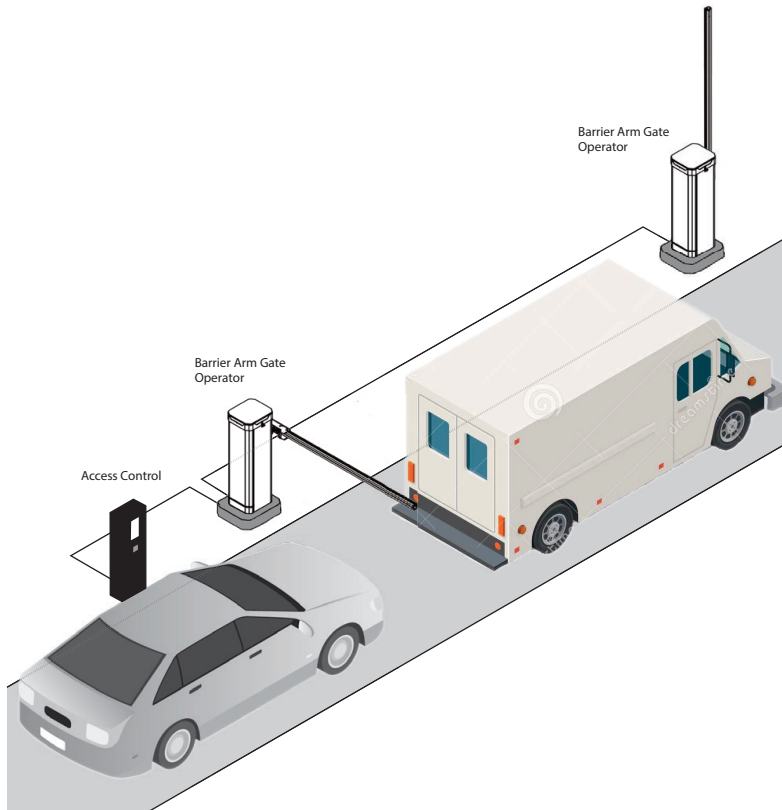

SEQUENTIAL MERGE CONFIGURATION

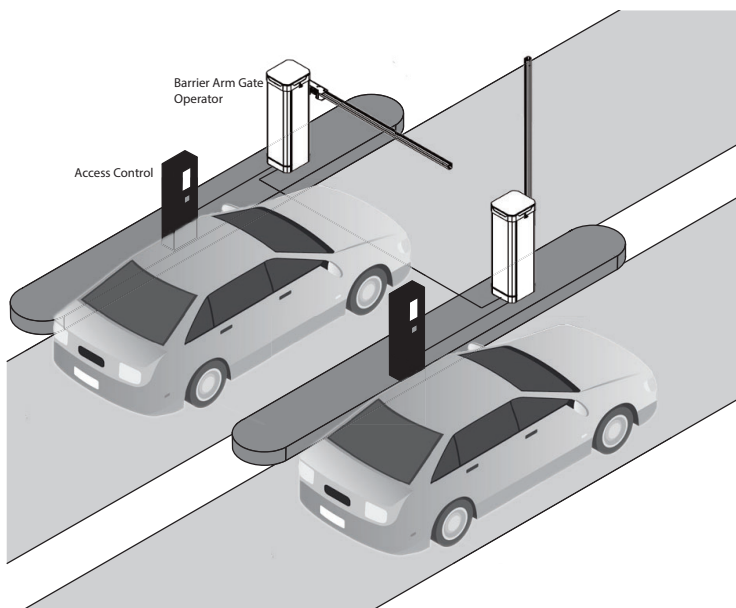

Configuration (continued)

Parking/Ticketing

MULTI-VEHICLE TRACKING

- Multi-Vehicle Tracking provides the ability to keep the gate open for multiple vehicles by counting how many are still inside and only closing once all have exited.
- On vehicle entry, the arming loop detects the presence of a vehicle and activates the Shadow Aux Relay if configured in Relay Configuration. This signals the system to increment the Multi-Vehicle Count (MVC) when an Open command is received via the Expansion Board (e.g., from a kiosk or access control device).
- If the vehicle proceeds to the interrupt loop, the Interrupt Aux Relay is activated if configured in Auxiliary Relay Configuration. This holds the gate open and pauses the Timer-to-Close (TTC).
- Each time a vehicle exits the interrupt loop, the MVC decreases by one. The gate remains open as long as the MVC is greater than zero (and any loops are active).
- When MVC reaches zero, and both the shadow and interrupt inputs are inactive, the gate will close.
- If another vehicle triggers the shadow loop (arming loop) and completes a vend before the gate closes, the MVC is incremented, and the cycle repeats.

NOTE: If a vehicle triggers the arming loop, increments MVC, and then backs out without triggering the interrupt loop, the MVC will remain incremented. Once the shadow input is deactivated (i.e., the vehicle leaves the arming zone), the TTC resumes even though MVC is still greater than zero. Once the TTC equals zero, the MVC resets to zero and the gate will close.

NOTE: Multi-vehicle Memory and TRAP/SAMs are not always compatible with each other. Do not activate in a TRAP/SAMs system without checking site specifications to validate that it's appropriate. When both multi-vehicle tracking and TRAP/SAMs are enabled the inputs can be utilized differently.

PARKING/TICKETING CONFIGURATION

TICKETING SYSTEM INTEGRATION

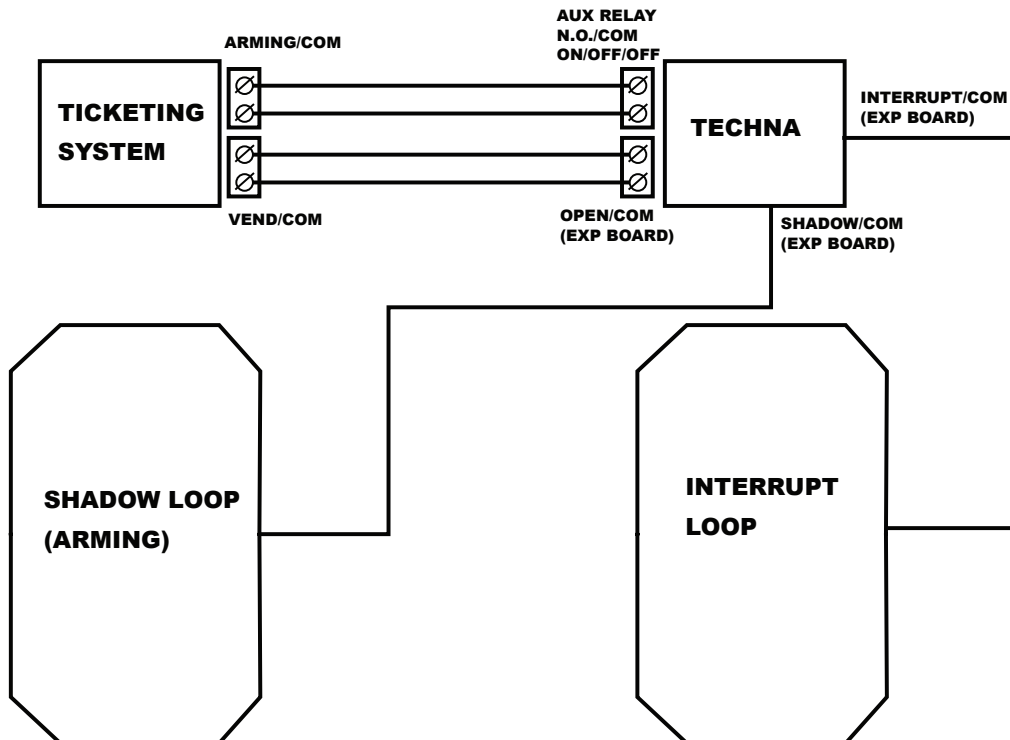

NOTE:
-ALL TICKETING SYSTEM WIRING/CONFIGURATIONS GO THROUGH THE TECHNIA EXPANSION BOARD ONLY.
-ALL LOOP TERMINATIONS GO THROUGH TECHNIA EXPANSION BOARD ONLY, NOT TICKETING SYSTEM.

Configuration (continued)

2 Close and Secure Cabinet

Before securing the door, follow the instructions in the Adjustment section to adjust the limits, speed, and force.

1. Close the operator cabinet door.
2. Close the operator cover.
3. Lock the operator.

3 Install Warning Signs

Installers **MUST** install the UL required warning signs. The signs **MUST** be installed in plain view on **both sides** of each barrier arm gate operator installed. Use the fastening holes in each corner to permanently secure the sign.

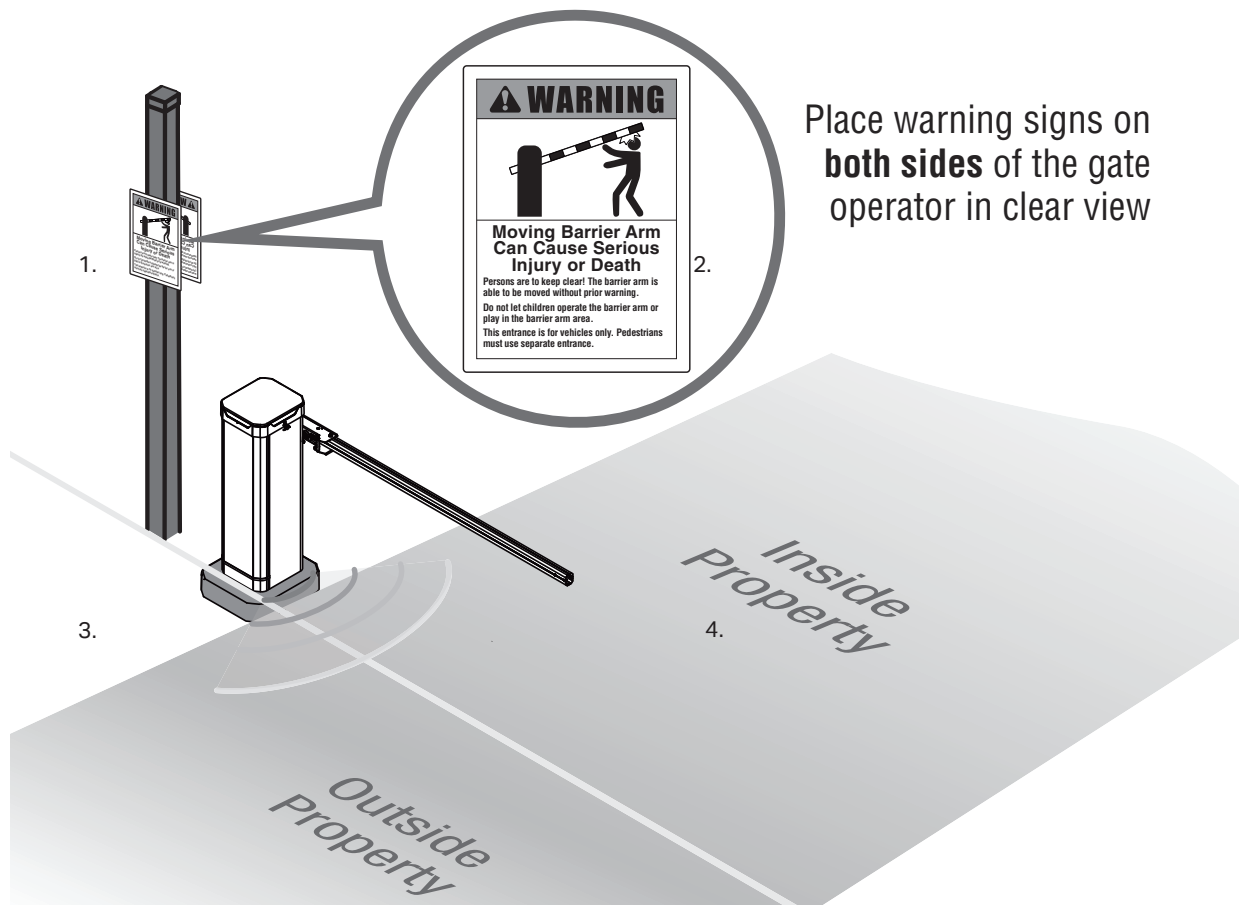

Programming

Antenna Assembly

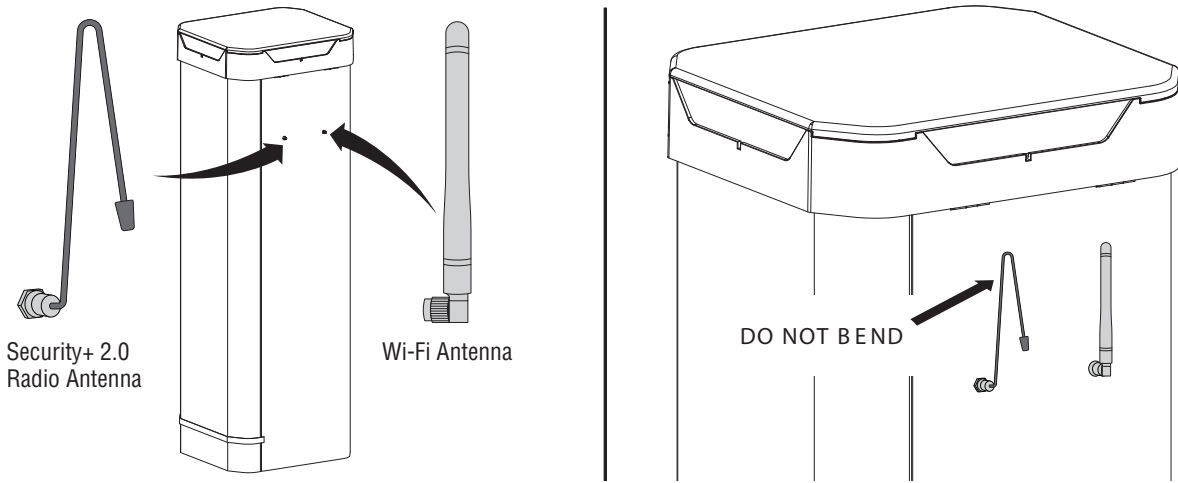

Security+ 2.0® Transmitters (Not Provided)

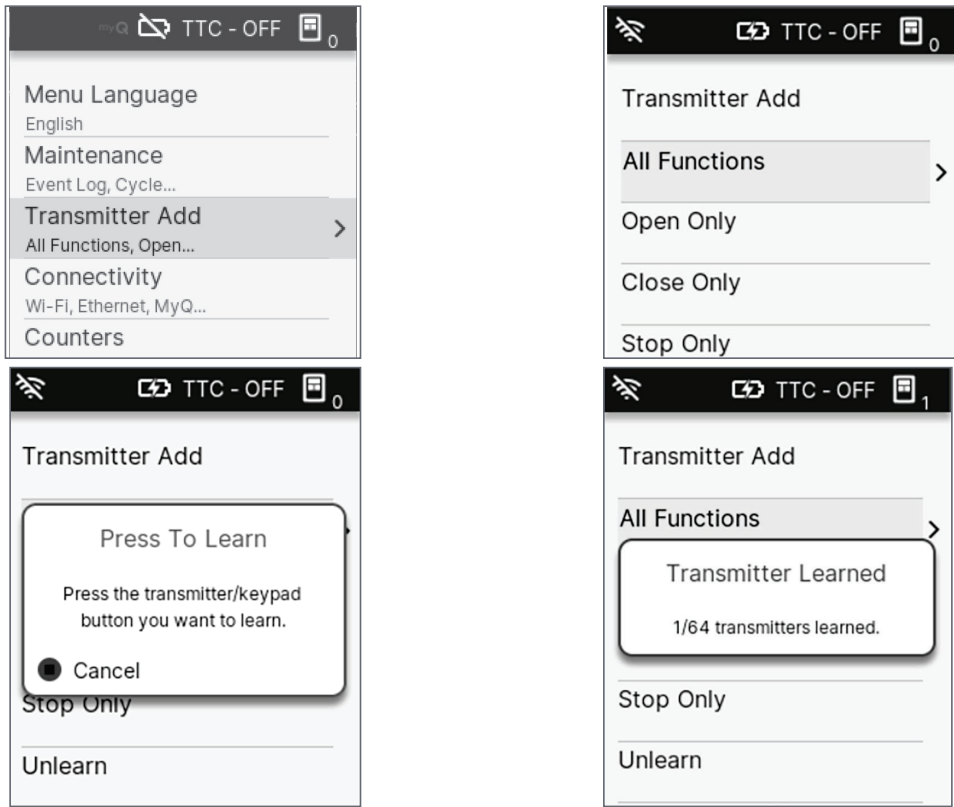

A total of 64 Security+ 2.0® remote controls or KPW250 keypads can be programmed to the operator. When the operator's memory is full, it exits the programming mode and the remote control is not programmed. The memory needs to be erased before programming any additional remote controls.

In addition, up to 10 HomeLink® v5 devices can be learned to the operator following the same Transmitter Add process. These devices are unlearned together with transmitters.

NOTE: If installing an 86LM to extend the range of the remote controls, DO NOT straighten the antenna.

Programming (continued)

There are 3 different options for programming the remote control, depending on how you would like the remote control to function. Choose a programming option:

Option	Description	Programming Steps
Single button as OPEN only	Program a single button on the remote control for open only. The Timer-to-Close can be set to close the gate.	<ol style="list-style-type: none"> 1. On the LCD Menu, navigate to "Transmitter Add". Press the Enter button to scroll to "Open Only". 2. Select "Learn" and press the Enter button. 3. When the LCD Menu prompts with the message "Press to Learn", press the remote control button that you would like to program.
Single button (SBC) as OPEN, CLOSE, and STOP	Program one remote control button as an open, close, and stop.	<ol style="list-style-type: none"> 1. On the LCD Menu, navigate to "Transmitter Add". Check that "All Functions" is displayed on the top line. 2. Select "Learn" and press the Enter button. 3. When the LCD Menu prompts with the message "Press to Learn", press the remote control button that you would like to program.
Three separate buttons as OPEN, CLOSE, and STOP	Program each remote control button as an open, close, and stop.	<ol style="list-style-type: none"> 1. On the LCD Menu, navigate to "Transmitter Add". 2. Select "Open Only", "Close Only", or "Stop Only", depending on the desired function. 3. Select "Learn" and press the Enter button. 4. When the LCD Menu prompts with the message "Press to Learn", press the remote control button that you would like to program.

The operator automatically exits learn mode (the LCD displays "Transmitter Learned") if programming is successful. To program additional Security+ 2.0® remote controls or remote control buttons, repeat the programming steps above.

<p>NOTICE: This device complies with Part 15 of the FCC rules and Industry Canada's license-exempt RSSs. Operation is subject to the following two conditions: (1) this device may not cause harmful interference, and (2) this device must accept any interference received, including interference that may cause undesired operation. Any changes or modifications not expressly approved by the party responsible for compliance could void the user's authority to operate the equipment.</p> <p>This device must be installed to ensure a minimum 20 cm (8 in.) distance is maintained between users/bystanders and device.</p> <p>This device has been tested and found to comply with the limits for a Class B digital device, pursuant to part 15 of the FCC rules and Industry Canada ICES standard. These limits are designed to provide reasonable protection against harmful interference in a residential installation. This equipment generates, uses and can radiate radio</p>	<p>frequency energy and, if not installed and used in accordance with the instructions, may cause harmful interference to radio communications. However, there is no guarantee that interference will not occur in a particular installation. If this equipment does cause harmful interference to radio or television reception, which can be determined by turning the equipment off and on, the user is encouraged to try to correct the interference by one or more of the following measures:</p> <ul style="list-style-type: none"> • Reorient or relocate the receiving antenna. • Increase the separation between the equipment and receiver. • Connect the equipment into an outlet on a circuit different from that to which the receiver is connected. - • Consult the dealer or an experienced radio/TV technician for help.
---	--

Programming Security+3.0™ (SP3) MAX Remote Controls (Not Provided)

 <h1 style="margin: 0;">CAUTION</h1>
<p>The gate will move during programming and verification. Ensure the area of the gate, including entire path of motion and all ENTRAPMENT zones, are clear of people, vehicles, and obstructions during programming.</p>

The MAX versions of SP3 remote controls that are compatible with the CBG, PBG and IBG Operators are the following:

- 1-Button: CH361
- 2-Button: L932M, CH382
- 3-Button: L993M, CH363

Read these instructions in their entirety before programming the remote control.

Programming (continued)

The remote control buttons are pre-set to Security+ 3.0 out of the box. The following steps explain how to put the remote into Programming mode and program it to the CBG, PBG and IBG gate operator.

- **Important Note on Multi-Button Use:** These instructions are for programming the remote control for single-button control of gate open/close/stop functions. If your application requires 3-button functionality, where buttons on the remote are assigned separately to gate OPEN CLOSE STOP functionality, STOP. Do not use the Security+ 3.0 Max Remote. Use model 813LMX (Security+ 2.0 E-DIP) instead, which is fully compatible with TECHNA operators and receivers. Refer to *Programming Security+ 2.0 Transmitters (Not Provided)* on the previous page for programming Security+ 2.0 Remote Controls.

STEP 1: PUT THE SP3 REMOTE CONTROL INTO PROGRAMMING MODE

Follow the instructions according to which type of remote you have:

- **1-Button remote (CH361):** Press and release the remote button 6 times within 4 seconds. The red LED will turn solid to confirm programming mode is active.
- **2-Button remote (L932M, CH382):** Press and hold both buttons simultaneously until the red LED turns solid (typically 6 seconds), then release the buttons.
- **3-Button remote (L993M, CH363):** Press and hold the two smaller buttons simultaneously until the red LED turns solid (typically 6 seconds), then release the buttons.

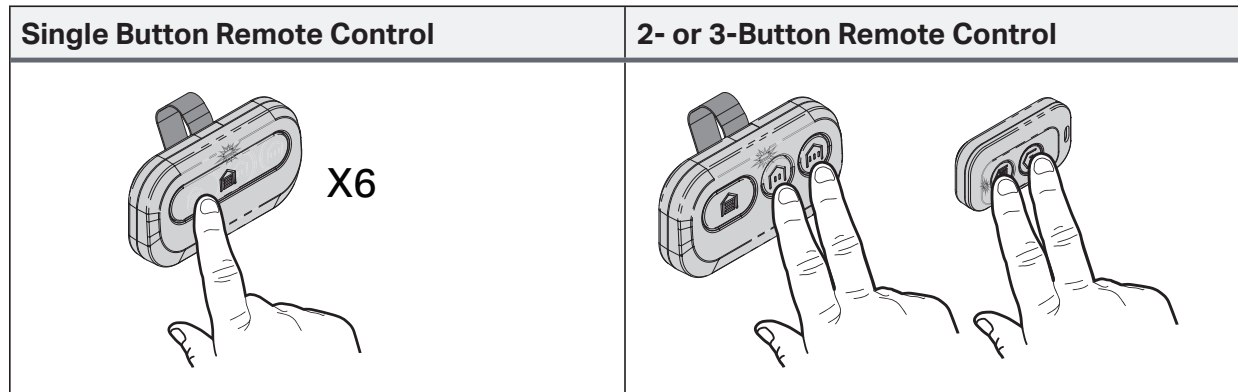

A solid LED means the remote is in Programming mode.

STEP 2: PROGRAM TO THE TECHNA OPERATOR

1. Go to the main control board on the TECHNA operator. Use the navigation buttons:
 - Green arrow = Enter
 - Up/Down arrows = Scroll
 - Red Stop button with stop symbol = Back out of menuPress the green arrow to enter the menu.
2. Scroll to Transmitter Add and press the green arrow.
3. Select ALL FUNCTIONS for SBC (Single Button Control).
4. Select LEARN and press Enter.
5. On your remote, press the button you want to use:
 - MAX Remote: Press the button twice.
 - Universal Remote: Press the button three times.
6. The LCD will display SBC learned and the LED on your remote will flash intermittently.
7. Wait for the LCD to display Transmitter learned.
8. Exit the menu and return to the main screen.
9. As the operator begins to move and while the LED on the remote blinks intermittently, press the button on the remote ONCE.

Programming (continued)

STEP 3: VERIFY PROGRAMMING

- Press the programmed remote button.
- If successful, the gate will move.
- If unsuccessful, repeat programming steps.

Programming Security+3.0™ Keypads and/or Universal Remote Controls (Not Provided)

Instructions for programming Security+3.0 keypads and/or universal remote controls are located on the LiftMaster support site. They can also be found through the QR code below.



myQ® Smart Facility Access

One Platform allows you to manage access for unlimited facilities, users and vehicles.

The myQ® Smart Facility Access allows you to control all your access points in the facility from the myQ® website application from anywhere. Monitor and control your vehicular access doors, gated entry locations, and even dock positions from a universal platform. myQ® technology uses an Ethernet, Wi-Fi, or 900MHz signal connection to communicate securely from your connected devices to myQ® enabled operators and accessories.

Setup a myQ® Smart Facility Access Account

NOTE: If you have an existing myQ® account, your myQ® Business™ account will have the same password.

We have made the account setup process easier than ever. It's completely self-service. Go to account.myq.com and begin the process.

1. Select Country, Name, email, and create password.
2. Verify the email with a 4-digit code.
3. Select property manager or partner.
4. To create a myQ® Facility, select property type, property name, property manager information. You are now ready to access your dashboard and all other myQ® features.
5. Set up the Facility and add users and groups to provide access to the Facility (refer to the available Help in myQ® Business™).
6. You will get a welcome email from LiftMaster. Accept the invitation and register or login to your account.
7. Set up the Facility and add users & groups to provide access to the Facility (refer to the available Help in myQ® Business™).
8. Follow on-screen prompts to get your Gate Operator and additional devices connected.

Programming (continued)

Connect Internet

The gate operator can connect to the Internet with a wired connection, a Wi-Fi® (wireless) connection, or a 900MHz gateway connection. See "Internet Requirements" on page 9.

OPTION 1 WIRED CONNECTION – ETHERNET (DHCP AND STATIC)

The Local Area Network (LAN) port is a 10/100 Ethernet interface with an RJ45 jack for connecting the gate operator to a hub, switch, or router in order for it to gain connectivity to the Internet. Use a straight, (i.e., non-crossover) Cat5e, or Cat6 cable to connect to a local hub, switch or router. This type of cable is referred to as an Ethernet cable in this manual.

1. Connect an Ethernet cable from the hub, switch, or router to the LAN port on the main control board of the operator.
2. On the LCD Menu, navigate to Connectivity > Wi-Fi, Ethernet > Learn to start the Ethernet provisioning process.
3. Enabling the Wired Connection on the LCD menu will activate the operator's Wi-Fi Access Point Page to allow for further configuration of the Wired Connection. On your mobile device, go into Wi-Fi configuration and look for the gate operator's Wi-Fi network. The Wi-Fi Access Point Page will be "MyQ-xxx" where xxx is the last three digits of your gate operator's CP#.

NOTE: Once the learning process is started any previous connection, configuration, or credential will be deleted.

4. If "Internet may not be available" message is received, select "keep Wi-Fi connection".
5. Open a web browser (e.g., Edge, Chrome) and enter either **setup.myqdevice.com** or **192.168.1.1**.
Note that if you exit the gate operator's MyQ-xxx Wi-Fi network, you will need to open a new web browser and enter setup.myqdevice.com or 192.168.1.1 to restart the configuration after re-connecting to the gate operator's MyQ-xxx Wi-Fi network. If page cannot be reached with myqdevice.com, try 192.168.1.1.
6. Select Start to see the current Internet connection method.
7. For DHCP, select Ethernet DHCP and click on "Next" icon.
8. For Static, select Ethernet Static and click on "Next" icon. Then fill in the information and click on "Next" icon.
9. If the operator's Ethernet icon is not active or if the phone is still on the "connecting to Internet" screen after 3 minutes, check the connections on operator and Ethernet hub. Resolve and repeat from Step 1. When connected properly, there will be a congratulation message indicating that your device is connected. The Ethernet icon will be solid on the operator's LCD display.
10. From your mobile device, exit the MyQ-xxx Wi-Fi Access Point Page.

OPTION 2 WI-FI® (WIRELESS)

On the LCD Menu, navigate to Connectivity > Wi-Fi, Ethernet > Learn to start the Wi-Fi provisioning process.

NOTE: Once the learning process is started any previous connection, configuration, or credential will be deleted.

1. Enabling the Wi-Fi Connection on the LCD menu will activate the operator's Wi-Fi Access Point Page to allow for further configuration of the Wi-Fi Connection. On your mobile device, go into Wi-Fi configuration and look for the gate operator's Wi-Fi network. The Wi-Fi Access Point Page will be "MyQ-xxx" where xxx is the last three digits of your gate operator's CP#.
2. If "Internet may not be available" message is received, select "keep Wi-Fi connection".
3. Open a web browser (e.g., Edge, Chrome) and enter either **setup.myqdevice.com** or **192.168.1.1**.
Note that if you exit the gate operator's MyQ-xxx Wi-Fi network, you will need to open a new web browser and enter setup.myqdevice.com or 192.168.1.1 to restart the configuration after re-connecting to the gate operator's MyQ-xxx Wi-Fi network. If page cannot be reached with myqdevice.com, try 192.168.1.1.
4. Select Start to see the current Internet connection method.
5. Select Wi-Fi and click on "Next" icon.
6. Select your site's Wi-Fi network.
7. Enter your Wi-Fi network password and then click on "Next" icon.
8. Click "Next" icon again to acknowledge update.
9. If the operator's Wi-Fi icon is not active or if the phone is still on the "connecting to Internet" screen after 3 minutes, check the Wi-Fi router location and signal strength. Resolve and repeat from Step 1. When connected properly, there will be a congratulation message indicating that your device is connected. The Wi-Fi icon will be solid on the operator's LCD display.
10. From your mobile device, exit the MyQ-xxx Wi-Fi Access Point Page.

Programming (continued)

OPTION 3 CONNECT THROUGH LIFTMASTER INTERNET GATEWAY (NOT PROVIDED)

NOTE: When using a LiftMaster Internet Gateway, firmware updates of the operator will not be supported. It is recommended to setup the operator's Ethernet or Wi-Fi Internet connections to allow the operator to receive firmware updates. To program the operator to the LiftMaster Internet Gateway:

1. Connect an Ethernet cable between the LiftMaster Internet Gateway and the network router.
2. Connect power to the LiftMaster Internet Gateway.
3. Download the myQ® App.
4. Set up an account and follow the app instructions to add your gate operator.
5. On the LCD Menu of the gate operator, navigate to "Controls > myQ Gateway > Learn".
6. The LiftMaster Internet Gateway pairs to the operator if it is within range.

The gate operator can then be controlled through the myQ® App.



To Erase the Gateway:

1. On the LCD Menu, navigate to "Controls > myQ Gateway > Unlearn".
2. Select "Unlearn All" and confirm.
3. The LCD displays the message "Devices Unlearned".

CAP PRODUCT CONNECTED ACCESS PORTAL

The CAP product can communicate wirelessly to LiftMaster® DC vehicular barrier arm gate operators to send open commands, monitor gate position, and send email notifications if an error occurs in the operator (email notifications are configured in myQ® Business™). Multiple gate operators can be paired with CAP products - one for each primary and auxiliary relay. If using dual gates, program the CAP product to the primary operator.

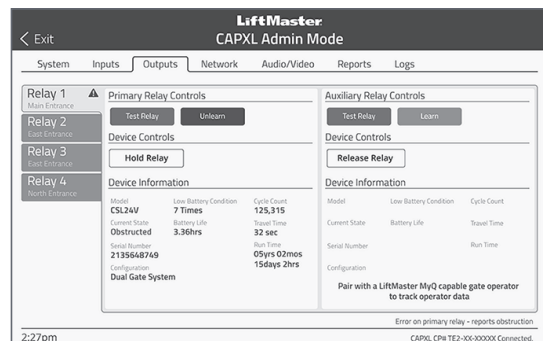

Programming (continued)

To Program the CAP Product:

1. Enter Admin Mode: See CAP product installation manual for instructions on entering Admin Mode.
2. Select Outputs and Relay: Select the Outputs tab. Then select the desired relay on the left-hand side.
3. On the LCD Menu of the gate operator, navigate to "Controls > Access Device > Learn".

NOTE: The operator times out of programming mode after 180 seconds.

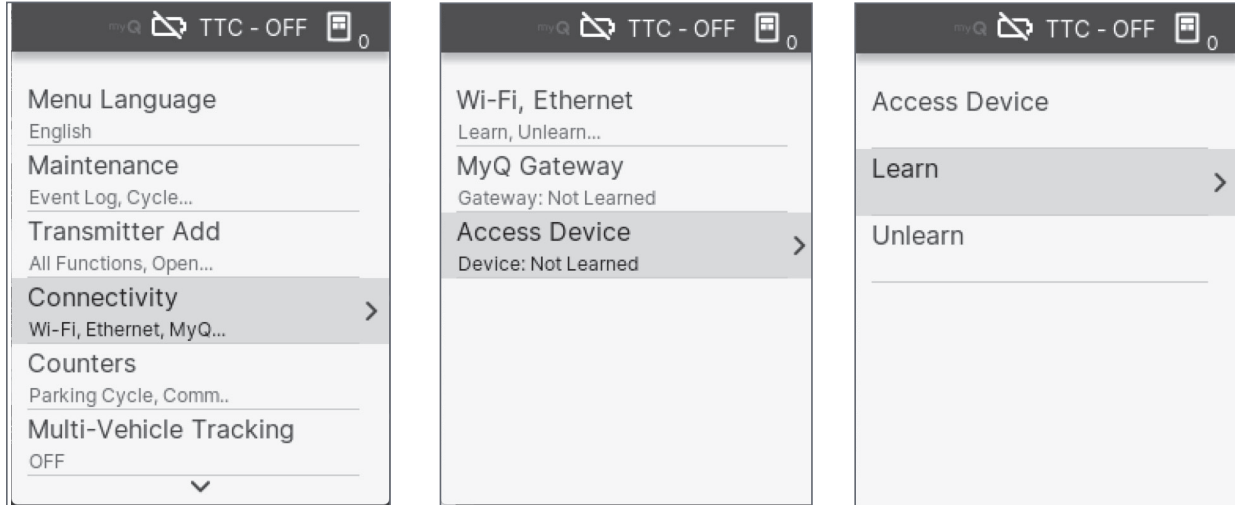

4. Select the LEARN button on the display. The Learn button changes from blue to red. The CAP product beeps once and the gate operator LCD display Device Learned, indicating programming is successful.
5. Validate functionality by selecting Test Relay on the CAP product display.

For more information, refer to the CAP product documentation.

myQ® Business™

To find out more on how to simply secure all of your access points with an easy to manage integrated system, myQ Business, please visit: www.myqbusiness.com.

ERASE ALL TRANSMITTER AND HOMELINK® DEVICES

1. On the LCD Menu, navigate to "Transmitter Add > All Functions > Unlearn All > Enter".
2. Enter "Unlearn All" to confirm on the LCD menu.
3. The LCD will display the message "Transmitters Unlearned".

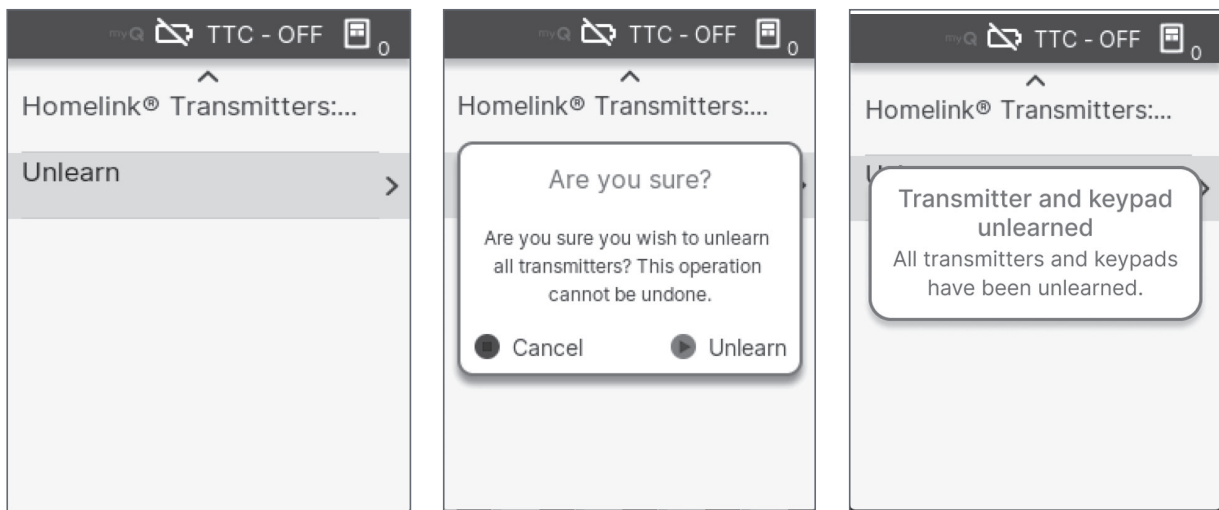

Programming (continued)

UNLEARN MONITORED SAFETY DEVICES

1. Remove the safety device wires from the terminal block.
2. To remove all Monitored Safety Devices, on the LCD Menu, navigate to "Monitored Eyes and Edges > Relearn All Monitored > Enter". (See screenshot)
3. Select the Reset option from the menu. (See screenshot)
4. This will re-learn all remaining connected safety devices.

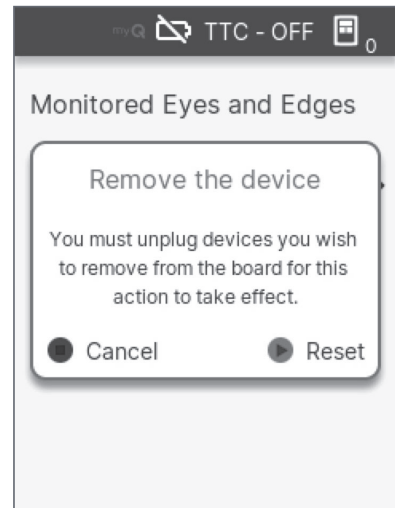
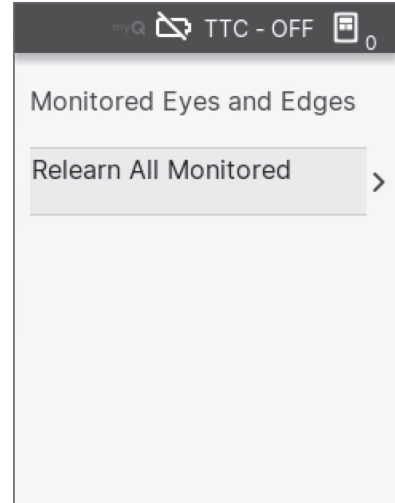

Operation

Modes of Operation

The following are example setups for the barrier arm gate operator. Your specific site requirements may be different. Always setup the operator system to the site requirements, including all necessary safety devices.

RESIDENTIAL: One to four residential homes sharing a gated entrance/exit, allowing vehicle access trumps security concerns.

COMMERCIAL/GENERAL ACCESS: A residential community (more than four homes) having one or more gated entrances/exits, allowing vehicle access trumps security concerns.

COMMERCIAL: Business site where security (gate closed) is important.

INDUSTRIAL: Large business site where security is required.

Setting	Residential	Commercial/General Access	Commercial	Industrial	Parking
Quick Close switch setting	Normally set to OFF. Normal gate close (timer or control).	Normally set to OFF. Normal gate close (timer or control).	Normally set to OFF. Normal gate close (timer or control).	Set to ON. Open gate will close immediately when vehicle passes Interrupt loop.	Set to ON when not using Multi-Vehicle Tracking.
AC Fail Open switch setting	Normally set to BATT. Run on battery if AC power fails.	Normally set to BATT. For local jurisdiction requirement, set to OPEN so that the gate opens approximately 15 seconds after AC power fail.	Normally set to BATT. Run on battery if AC power fails.	Normally set to BATT. Run on battery if AC power fails.	Normally set to BATT. Run on battery if AC power fails.
Low Battery Menu setting	Normally set to OPEN. If powered from battery and battery is low, gate automatically opens and stays open.	Normally set to OPEN. If powered from battery and battery is low, gate automatically opens and stays open.	Normally set to CLOSE. If powered from battery and battery is low, gate stays closed.	Normally set to CLOSE. If powered from battery and battery is low, gate stays closed.	Normally set to BATT. Run on battery if AC power fails.
Anti-Tail switch setting	Normally set to OFF. CLOSE EYES/ Interrupt loop reverses a closing gate.	Normally set to OFF. CLOSE EYES/Interrupt loop reverses a closing gate.	Set to ON. In attempt to prevent vehicle tailgating, CLOSE EYES/ Interrupt loop pauses a closing gate.	Set to ON. In attempt to prevent vehicle tailgating, CLOSE EYES/ Interrupt loop pauses a closing gate.	Set to ON. In attempt to prevent vehicle tailgating, CLOSE EYES/ Interrupt loop pauses a closing gate.
Aux Relay Out - Open limit switch	Typically not required.	Use with SAMS (Sequence Access Management System).	1. Use with SAMS (Sequence Access Management System). 2. Connect "Gate Open" indicator (e.g. light).	1. Use with SAMS (Sequence Access Management System). 2. Connect "Gate Open" indicator (e.g. light).	Typically not required.
Aux Relay Out - Not Closed	Typically not required.	Typically not required.	Connect "Gate Close/ Secure" indicator (e.g. light).	Connect "Gate Close/Secure" indicator (e.g. light).	Typically not required.
Aux Relay Out – Gate Motion	Attach alert signal (audible or visual alert system).	Attach alert signal (audible or visual alert system).	Attach alert signal (audible or visual alert system).	Attach alert signal (audible or visual alert system).	Typically not required.
Fire Dept Open Input	Typically not required.	Connect emergency access system (Knox box switch, SOS system, etc.).	Typically not required.	Typically not required.	Connect emergency access system (Knox box switch, SOS system, etc.).
Multi-Vehicle Tracking Menu Setting	Normally set to OFF. Normal gate close (timer or control).	Normally set to OFF. Normal gate close (timer or control).	Normally set to OFF. Normal gate close (timer or control).	Normally set to OFF. Normal gate closes with Quick Close.	Set to ON. When Multi-Vehicle Tracking is enabled, the open gate will close when Multi-Vehicle Count is 0.

Operation (continued)

Service Mode

The operator can be set in Service Mode to allow safe work on the operator.

When Service Mode is active, gate remains at fully open position and all wired and wireless commands are ignored.

To activate Service Mode:

1. Navigate to "Maintenance > Service Mode > ON" in the display menu and press Enter.
2. Press Back/Stop button 3 times to exit the menu.
3. Arm will move to fully Open position.

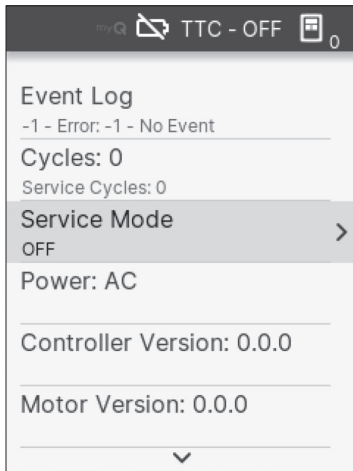

Service Mode is indicated on the display and top bar of menu.

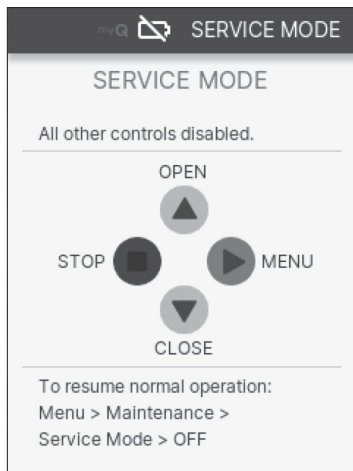

While in Service Mode, the Open and Close buttons on the main control board can move the arm, if needed.

Operation (continued)

Operator Alarm

To set the functionality of the installed alarm (if equipped), navigate to the Alarm menu and press Enter.

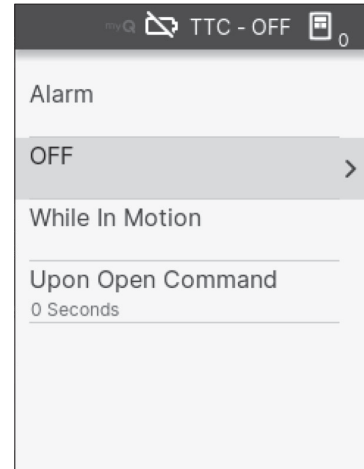

Option	Description
OFF	Alarm is disabled (default).
While In Motion	Alarm will sound while arm is opening or closing.
Upon Open Command	Alarm will sound from when gate starts opening until the timer expires.

For Upon Open Command, an extra step is required to set the desired time and press Enter

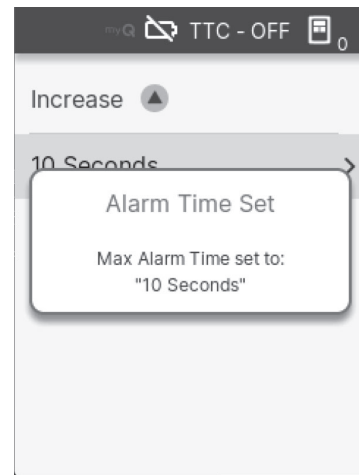
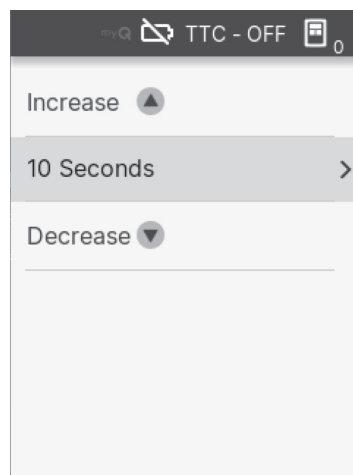
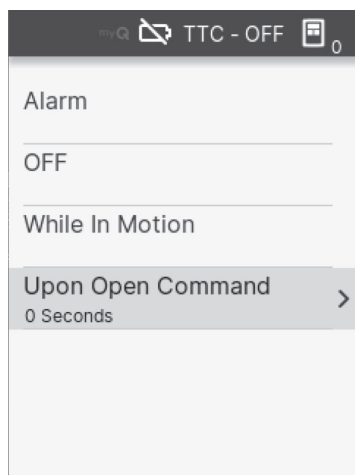

Maintenance



WARNING

To reduce the risk of SEVERE INJURY or DEATH:

- READ AND FOLLOW ALL INSTRUCTIONS.
- TEST THE GATE OPERATOR MONTHLY. The barrier arm MUST reverse on contact with an object, or by hand. Barrier arm must reverse when non-contact sensors are activated. After adjusting the force, speed, or the travel, retest the gate operator. Failure to adjust operator properly can increase the risk of INJURY or DEATH.
- ANY maintenance to the operator or in the area near the operator MUST NOT be performed until disconnecting the electrical power (AC or solar and battery) and locking-out the power via the operator power switch. Upon completion of maintenance the area MUST be cleared and secured, at that time the unit may be returned to service.
- Disconnect power at the fuse box BEFORE proceeding. Operator MUST be properly grounded and connected in accordance with national and local electrical codes. **NOTE:** *The operator should be on a separate fused line of adequate capacity.*
- For continued protection against fire, replace ONLY with fuse of same type and rating.
- KEEP GATES PROPERLY MAINTAINED. Read this manual. Have a trained gate systems technician make repairs to gate hardware.
- ALL maintenance MUST be performed by a trained gate systems technician.
- NEVER let children operate or play with gate controls. Keep the remote control away from children.
- Activate gate ONLY when it can be seen clearly, is properly adjusted and there are no obstructions to gate travel.
- ALWAYS keep people and objects away from the gate. NO ONE SHOULD CROSS THE PATH OF THE MOVING GATE.
- To reduce the risk of FIRE or INJURY to persons use ONLY LiftMaster part 29-NP712 for replacement batteries.
- The entrance is for vehicles ONLY. Pedestrians MUST use separate entrance.
- If forecasted wind speeds are greater than 60 mph, the gate arm should be uninstalled to minimize the risk of damage.
- Call 1.800.528.2806 with any questions.
- **SAVE THESE INSTRUCTIONS.**



CAUTION

- ALWAYS wear protective gloves and eye protection when changing the battery or working around the battery compartment.

Maintenance (continued)

Maintenance Chart

Disconnect all power (AC, solar, battery) to the operator before servicing.

NOTE: Avoid servicing the operator, main control board, motor board, and electronics during rain to avoid damage from water.

Description	Task	Check at least once every		
		6 Months	1 Year	2 Years
Safety Devices	Check and test inherent (built into the operator) and external devices for proper operation. Replace any safety devices that are not working properly. "Accessories" on page 73	X		
Warning Signs	Make sure they are present and replace if worn or broken, see "Repair Parts" on page 72.	X		
Spring Module	Inspect for wear or damage. Replace any broken springs or the complete module. Replace complete spring module after 3 million cycles of operation.	X		
Arm Bracket System	Check arm bracket bolts for any signs of loosening or any slippage on the output shaft. Replace if necessary.		X	
Arm	Check all arm bolts for any loosening signs, excessive arm bends, dents or other damage; replace arm when damaged.	X		
Accessories	Check all for proper operation. Replace any broken, damaged or missing parts.		X	
Electrical	Inspect all wire connections. Secure any loose connections and replace any broken or damaged components. If error code is present, check "Diagnostic Codes Table in Appendix."		X	
Chassis Mounting Bolts	Check for tightness. Tighten, or replace.		X	
All Bolts	Check for any loose bolts. Tighten, or replace.		X	
Operator	Inspect for wear or damage. Service worn and replace damaged parts.		X	
Diagnostic History	Review diagnostic history for identification of intermittent problems.		X	
Batteries	Inspect and test batteries. Replace if needed.			X

NOTES:

- Replace complete spring module after 3 million cycles. Can replace single springs if broken.
- High cycle usage may require more frequent maintenance checks.
- Limits may need to be adjusted after any adjustments to the arm bracket.
- It is suggested that while at the site, voltage readings be taken at the operator. Using a digital voltmeter, verify that the incoming voltage to the operator is within ten percent of the operator's rating.
- Anytime the arm bracket needs to be removed or adjusted, the spring tension must be removed first to safely disengage the counterbalance spring assembly from the gearbox. See REMOVING SPRING TENSION in Installation Step 4, Adjust the Counterbalance Spring Assembly section of the manual. Then follow the Installation instructions to Install the Barrier Arm.

BATTERIES

Batteries degrade over time depending on temperature and usage. Batteries do not perform well in extremely hot or cold temperatures. For best performance, the batteries should be replaced every 2 years. Use only LiftMaster part 29-NP712 for replacement batteries. The batteries contain lead and need to be disposed of properly. The operator comes with two 7AH batteries. Two 33AH batteries (A12330SGLPK), with battery harness model K41-0102-000 (not provided), may be used in place of the 7AH batteries.

Troubleshooting



WARNING

For continued protection against fire:

- Replace ONLY with fuse of same type and rating.

Diagnostic Codes

TO VIEW THE CODES

1. On the LCD display, navigate to "Maintenance > Event Log > ENTER".
2. Scroll down the list to see the Event Log list.
3. Press Enter to view the details of the highlighted Event Code.

TO SCROLL THROUGH THE SAVED CODES

The operator will only keep track of up to 50 codes, then will start saving over the oldest codes as new codes occur.

See "Appendix (continued)
Diagnostic Codes Table

Some codes are saved in the code history and some are not. If a code is not saved, it will briefly appear on the display as it occurs, then disappear." on page 78.

TO EXIT

Press the STOP button to exit. The display will also time out after two minutes of inactivity.

TO CLEAR THE EVENT LOG HISTORY

1. On the LCD display, navigate to "Maintenance > Event Log > Clear All - ENTER".
2. Press Enter to confirm.

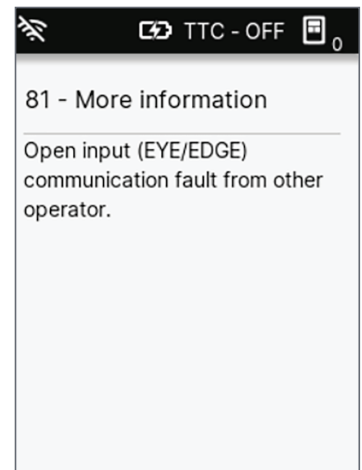
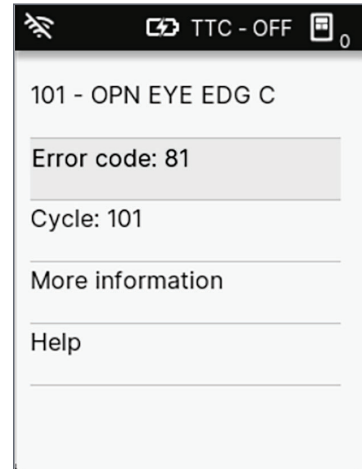

Solar

Solar Setup

When using the solar panels to power the operator, the menu setting for Solar Power must be turned on. On the LCD screen, navigate to the "Solar Power" option and select the "ON" option.

NOTE: Do not use both an AC and Solar Power inputs at the same time.

SOLAR PANEL(S)

SOLAR PANELS ARE NOT PROVIDED. SEE ACCESSORIES.

NOTE: The use of photoelectric sensor heaters (model LMTBUL) is NOT recommended in solar applications.

Solar Application Requirements

Solar rating: 40W MIN - 80W MAX, 24V

- A minimum of two 20 Watt solar panels in series (Model SP20W12V).
- A maximum of four 20 watt solar panels (Model SP20W12V)
- A heater cannot be used with a solar application.

SOLAR ZONES

Solar panel recommendations are based upon the average solar radiation and the temperature effects on batteries in the given zones as shown on the map below. Local geography and weather conditions may require additional solar panels. Solar powered gate operator installations are not supported in northern climates due to cold weather and a reduced number of hours of sunlight during the winter months. The cycles/day ratings are approximations. Ratings vary based on gate construction, installation, and temperature. Solar panels cannot be installed in areas that experience long periods of heavy fog, lake effect

- 1** ZONE 1 (6 Hours of Sunlight/Day): Ideal for solar application
- 2** ZONE 2 (4 Hours of Sunlight/Day): Recommended for solar application
- 3** ZONE 3 (2 Hours of Sunlight/Day): Success of solar application will depend on type of gate operator and location of the solar panel
- NOT AVAILABLE**

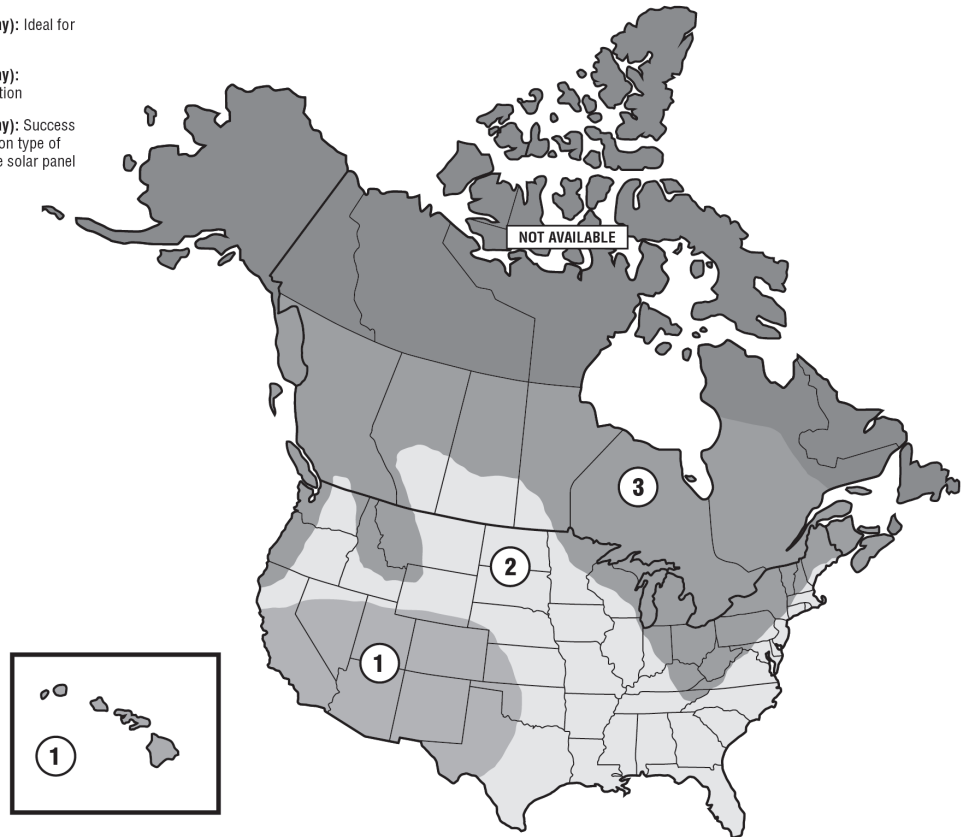

Solar (continued)

SOLAR USAGE GUIDE

All performance metrics are estimates and are subject to change at any time. Actual results vary due to variables specific to the site.

Typical System Standby Battery Current Consumption	
System Voltage	24V
System with Expansion and Relay boards disconnected and cabinet and arm LEDs disabled	35 mA
One or more LiftMaster remote controls programmed	+1 mA
myQ device or wireless dual gate programmed	+3 mA
Expansion board	+10 mA
Relay adapter board	+5 mA
Per loop detector LOOPDETLM	+4 mA
Wi-Fi connection	+15 mA
Photoelectric sensor heaters connected (not recommended)	+85 mA

NOTE: For additional details and specifications on solar usage, please refer to liftmaster.com.

NOTE: The use of photoelectric sensor heaters (model LMTBUL) is NOT recommended in solar applications.

Solar (continued)

BATTERY BACKUP PERFORMANCE (WITHOUT CHARGE POWER)

Battery Backup Gate Cycles		
	7 AH batteries	33 AH batteries
Gate Cycles	500	3000

Days of Standby		
Battery standby current draw (mA)	7 AH batteries	33 AH batteries
35	8	36
40	7	31
45	6	28
50	6	25
60	5	21
70	4	18
80	4	16
90	3.0	14
100	2.5	12
200	1.0	6

Solar (continued)

CBG24DC Estimated solar cycles per day 12ft arm, Medium Speed							
Panel Wattage	Battery standby current draw (mA)	Zone 1 (6 Hrs Sunlight/Day)		Zone 2 (4 Hrs Sunlight/Day)		Zone 3 (2 Hrs Sunlight/Day)	
		7 AH batteries	33 AH batteries	7 AH batteries	33 AH batteries	7 AH batteries	33 AH batteries
20 W Solar Panel	35	110	130	50	60		
	50	90	110		50		
	75	60	80				
	100		50				
	200						
40 W Solar Panel	35	240	340	130	190		60
	50	220	320	110	170		
	75	190	280	80	140		
	100	150	250	50	110		
	200		120				
60 W Solar Panel	35	320	560	180	320	50	110
	50	300	540	160	300		100
	75	270	500	130	270		70
	100	230	460	100	230		
	200	100	310		100		
80 W Solar Panel	35	340	780	190	460	60	170
	50	320	760	170	430		150
	75	280	720	140	400		120
	100	250	670	110	360		90
	200	120	510		220		

Solar (continued)

PBG24DC Estimated solar cycles per day 10ft arm, Medium Speed							
Panel Wattage	Battery standby current draw (mA)	Zone 1 (6 Hrs Sunlight/Day)		Zone 2 (4 Hrs Sunlight/Day)		Zone 3 (2 Hrs Sunlight/Day)	
		7 AH batteries	33 AH batteries	7 AH batteries	33 AH batteries	7 AH batteries	33 AH batteries
20 W Solar Panel	35	150	180	70	90		
	50	130	150	50	70		
	75	90	110				
	100	50	80				
	200						
40 W Solar Panel	35	340	470	180	270	50	80
	50	310	440	160	240		60
	75	260	390	120	190		
	100	220	350	80	150		
	200	60	170				
60 W Solar Panel	35	450	780	250	450	80	160
	50	420	750	220	420	60	140
	75	370	700	180	370		100
	100	320	640	140	330		60
	200	150	440		150		
80 W Solar Panel	35	480	1000+	270	640	90	240
	50	450	1000+	240	610	60	210
	75	400	1000+	200	560		170
	100	350	940	150	500		130
	200	170	720		310		

Solar (continued)

IBG24DC Estimated solar cycles per day 18ft arm, Medium Speed							
Panel Wattage	Battery standby current draw (mA)	Zone 1 (6 Hrs Sunlight/Day)		Zone 2 (4 Hrs Sunlight/Day)		Zone 3 (2 Hrs Sunlight/Day)	
		7 AH batteries	33 AH batteries	7 AH batteries	33 AH batteries	7 AH batteries	33 AH batteries
20 W Solar Panel	35	160	200	80	100		
	50	140	170	60	70		
	75	90	120				
	100	60	80				
	200						
40 W Solar Panel	35	370	510	200	290	60	90
	50	330	480	170	260		70
	75	280	430	130	210		
	100	240	380	90	170		
	200	60	180				
60 W Solar Panel	35	490	850	270	490	90	180
	50	460	820	240	460	60	150
	75	400	760	200	410		110
	100	350	700	150	350		70
	200	160	470		160		
80 W Solar Panel	35	520	1000+	290	700	90	260
	50	490	1000+	260	660	70	230
	75	430	1000+	210	600		190
	100	380	1000+	170	550		140
	200	180	780		330		

Solar (continued)

Solar Installation

POSITION

The location of the panel(s) is critical to the success of the installation. In general, the panel(s) should be mounted using the provided angle bracket facing due south. The solar panel(s) should be mounted in an area clear of all obstructions and shade from buildings and trees. If the panel(s) is not casting a shadow, the battery is not being charged.

NOTE: Tall trees or buildings that do not shade the solar panel(s) in the summer could shade the solar panel(s) during the winter months when the sun sits lower in the sky.

MAXIMUM WIRE LENGTH			
AMERICAN WIRE GAUGE (AWG)	40 WATTS OF PANELS	60 WATTS OF PANELS	80 WATTS OF PANELS
16	115 ft / 35.1m	80 / 24.4 m	60ft / 18.3 m
14	190 / 57.9 m	125 / 38.1 m	90ft / 27.4 m
12	300 / 91.4 m	200 / 61 m	150ft / 45.7 m
10	475 / 144.8 m	315 / 96 m	235ft / 71.6 m

Chart assumes: copper wire, 65°C drop, 30V nominal

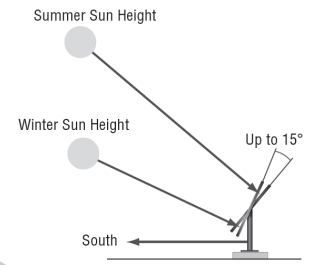
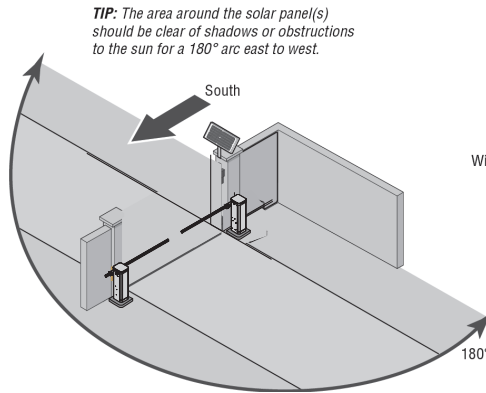
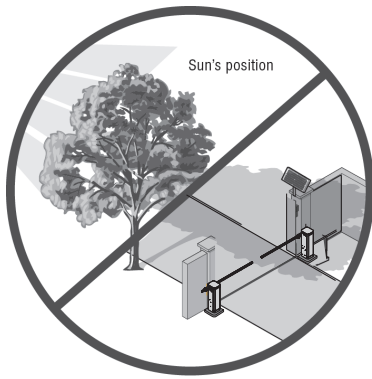

INSTALLATION

Solar panel(s) MUST be installed facing south. Use a compass to determine direction. Below are general instructions for installing the solar panel(s). Your installation may vary slightly depending on the solar panel purchased. Do not mount panels to or on building surface.

1. Position the mounting bracket on the mounting surface. Mark and drill holes.
2. Secure the solar panel to the mounting bracket using the hex bolts, hex nuts and washers provided.
3. Secure the solar panel to the mounting surface using lag screws provided.

WIRE THE SOLAR PANELS AND BATTERIES

40 Watts min. - 60 Watts max. for solar applications.

NOTE: 33AH batteries are strongly recommended for optimal solar performance.

1. Connect (+) wire from solar panels to (+) pin on CHARGE IN connector on the main control board.
2. Connect (-) wire from solar panels to (-) pin on CHARGE IN connector on the main control board.
3. Set the WALL XFMR/SOLAR switch to SOLAR as shown on page 71.
4. On the LCD menu, navigate to "Solar Power > ON > Enter".

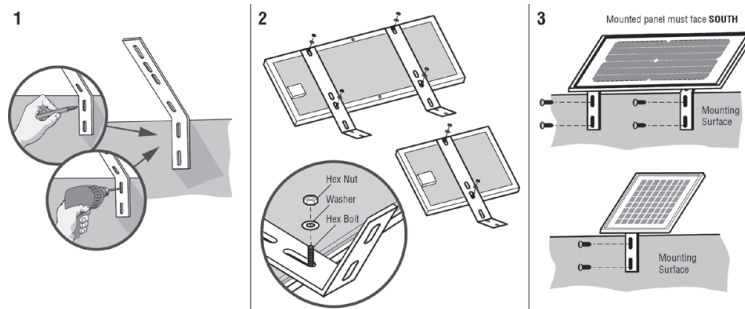
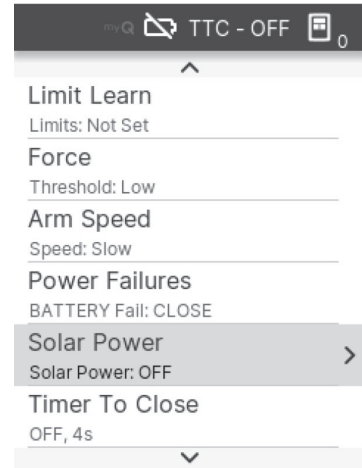

Solar (continued)

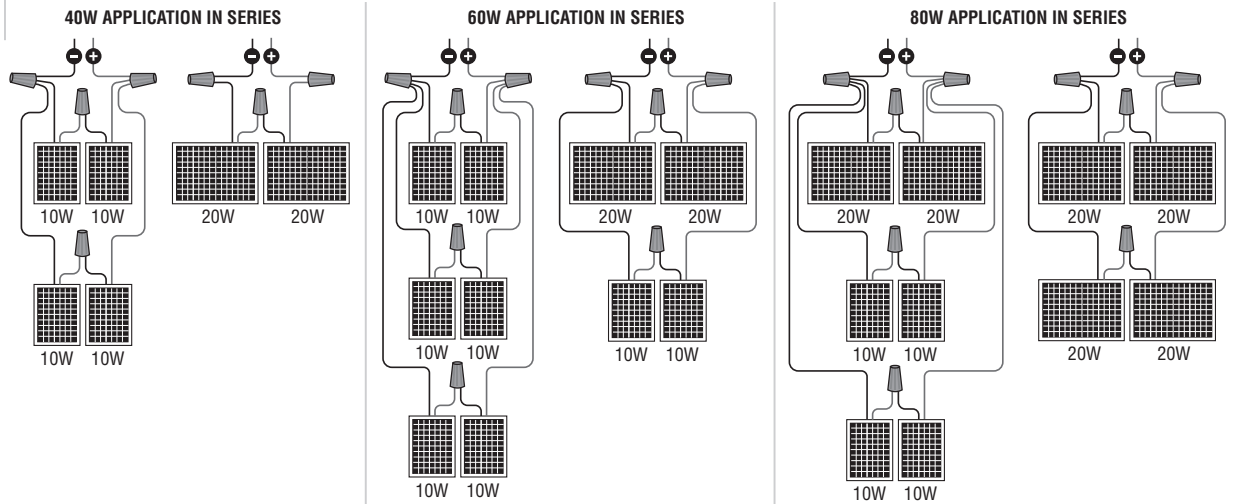
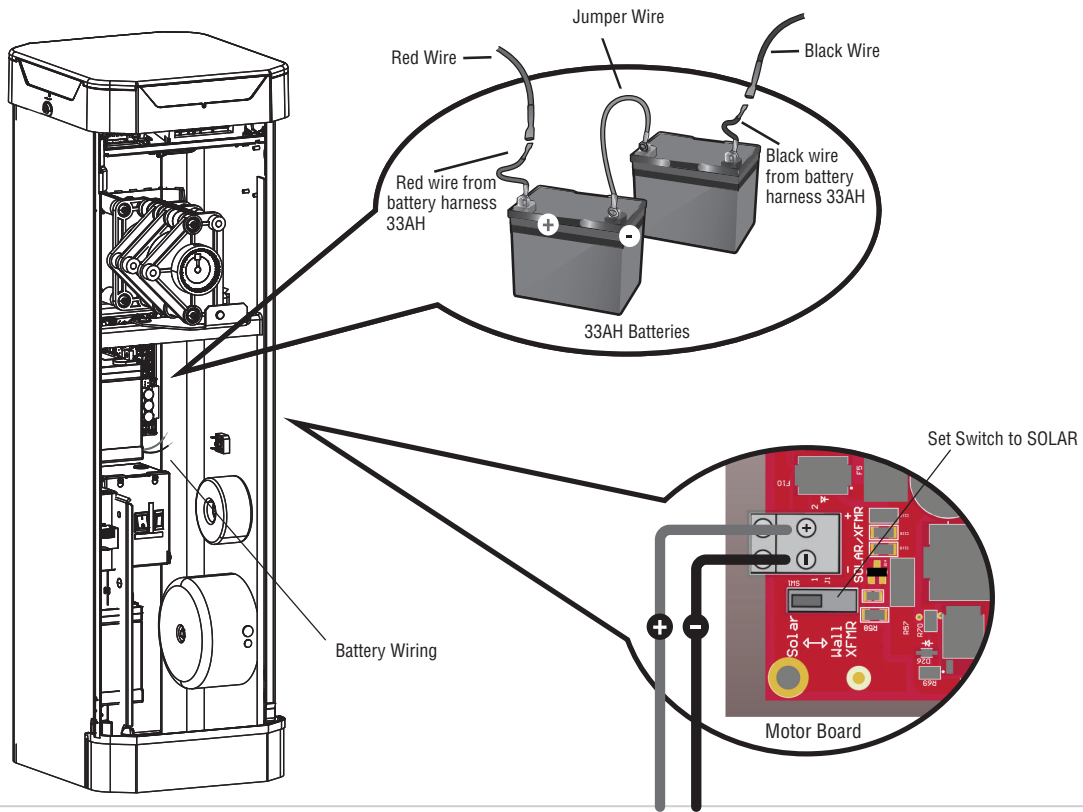

Repair Parts

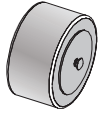

Transformer
K204C0211

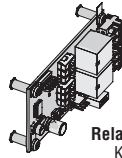

Relay Adapter Board
K41-0072-000

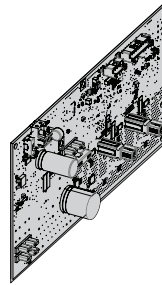

Main Control Board and Drive Board Set
K41-0575-000

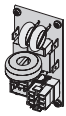
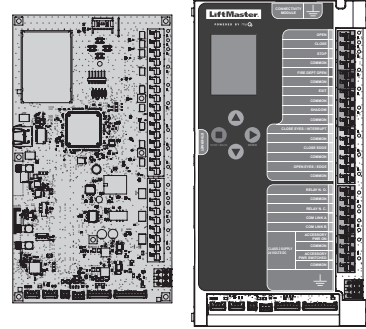

EMI Board
K1D7078

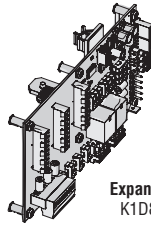

Expansion Board
K1D8387-1CC



Bridge Rectifier
K41-0083-000

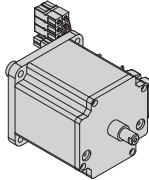

Motor
K41-0435-000

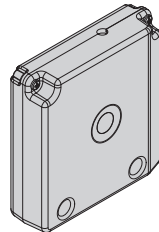

Limit System Encoder
K41-0450-000

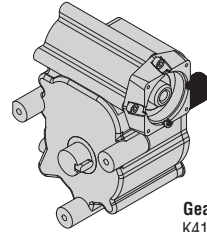

Gear Reducer
K41-0436-000

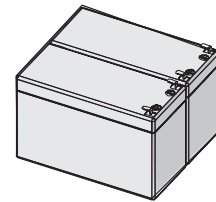

Battery, 7AH 12 VDC
K74-30762 (1)
29-NP712 (2)

Alarm
BGALARM



OVERVIEW

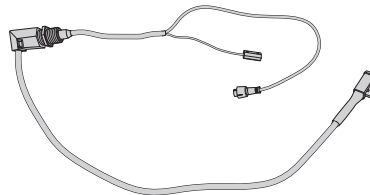
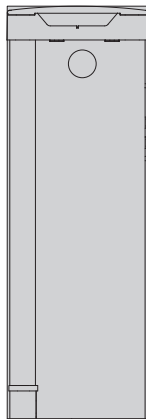

Arm to Housing Cable
K41-0447-000

NOT SHOWN

- K41-0432-000 TECHNA Plastic PCB Tray
- K41-0433-000 TECHNA PCB Pivot Assembly
- K41-0437-000 PBG Spring Module
- K41-0438-000 CBG Spring Module
- K41-0439-000 IBG Spring Module
- K41-0440-000 TECHNA CBG Arm Bracket Kit
- K41-0441-000 TECHNA Shaft Output Cover and Seal
- K41-0442-000 TECHNA Arm Retention Kit
- K41-0443-000 TECHNA LED Lid (White)
- K41-0444-000 TECHNA LED Lid (Grey)
- K41-0448-000 TECHNA Harness Kit
- K41-0449-000 TECHNA Arm Mounting Hardware
- K41-0451-000 TECHNA Antenna Kit
- K41-0452-000 TECHNA Lock and Key
- K41-0477-000 BG Replacement Spring Set
- K41-0545-000 BG Arm Magnets
- K41-0546-000 TECHNA BG Lid Gasket
- K41-0547-000 BG Spring Direction Switch
- K41-0550-000 TECHNA PBG Arm Bracket Kit
- K41-0553-000 Barrier Gate Warning Sign/Placard
- K41-0555-000 TECHNA Cabinet Door (White)
- K41-0556-000 TECHNA Cabinet Door (Grey)
- K41-0598-000 IBG Replacement Spring Set
- K41-0633-000 TECHNA IBG Arm Bracket Kit

Accessories

SAFETY DEVICES

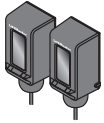

LiftMaster monitored through beam photoelectric sensor

Model LMTBUL

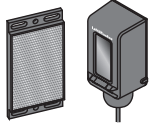

LiftMaster monitored retro-reflective photoelectric sensor

Model LMRRUL

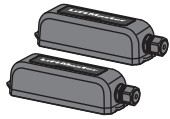

LiftMaster monitored wireless edge kit (transmitter and receiver)

Model LMWEKITU

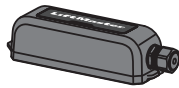

LiftMaster monitored wireless edge transmitter

Model LMWETXU



Small profile monitored edge (82-ft. roll)

Model S50

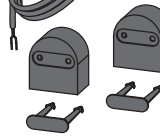

Small profile ends kit

Model S50E

REMOTE CONTROLS

LiftMaster offers a variety of LiftMaster remote controls to satisfy your application needs. Single-button to 4-button, visor or key chain. The following remote controls are compatible with all current gate operator models. Contact your authorized LiftMaster dealer for additional details and options.



3-button remote control

The 3-button remote control can be programmed to control the operator. Includes visor clip.

Model 893MAX



3-button mini-remote control

The 3-button remote control can be programmed to control the operator. Includes key ring and fastening strip.

Model 890MAX

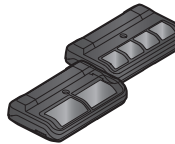

Security+ 2.0 learning remote control

One button can control a gate operator and the other(s) can control garage door(s). It can also be programmed to Security+ or Security+ 2.0 code format.

Models 892LT and 894LT

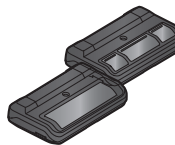

Programmable DIP Remote Controls

Ideal for applications requiring a large number of remote controls.

Models 811LMX and 813LMX



Wireless commercial keypad

Durable wireless keypad with blue LED backlight metal keypad, zinc-alloy metal front cover and 5 year 9V lithium battery. Security+ 2.0 compatible.

Model KPW250



Commercial access control receiver

Access control receiver for up to 1,000 devices (any combination of remote controls and wireless keyless entries).

Model STAR1000

Accessories (continued)

MISCELLANEOUS

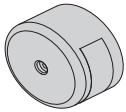

3-Phase Converter

Changes input voltage (208/240/480/575 VAC) to an output voltage of 120 VAC.

Model 3PHCONV

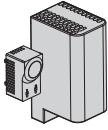

Barrier Gate Heater

The heater keeps the gearbox and batteries at a suitable temperature when the outside temperature is below -4°F (-20°C). The thermostat MUST be set between 45°F and 60°F (7°C and 15.5°C) to ensure proper gate operation. The heater can be powered by 110 to 250 VAC.

Model HTR

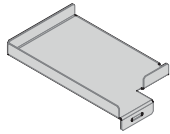

33AH Battery Tray

Battery tray, wire harness kit, and fasteners.

Model TRAY33AH

BGARMFOAM

BGALARM



Solar Panel Kit

This kit is to replace or add a solar panel to the operator application. (80W maximum)

Models SP10W12V (10 Watt, 12 V) and SP20W12V (20 Watt, 12V)

BATTERIES

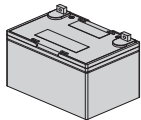

33AH Batteries Kit

Upgrade 33 AMP-Hour Battery, 12 VDC. Ideal for solar applications and extended battery backup. Two required.

Model A12330SGLPK

Must use TRAY33AH - mounting bracket.

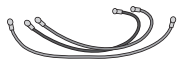

Battery Harness, 33AH

For 33AH battery applications.

Model K41-0102-000

ARTICULATING ARMS

BGARM10ART84

10' Functional Length Arm with 84" Clearance

BGARM10ART98

10' Functional Length Arm with 98" Clearance

BGARM12ART84

12' Functional Length Arm with 84" Clearance

BGARM12ART98

12' Functional Length Arm with 98" Clearance

STRAIGHT ARMS

BGARM10

10' Functional Length Arm

BGARM10LED

10' Functional Length Arm w/LEDs

BGARM12

12' Functional Length Arm

BGARM12LED

12' Functional Length Arm w/LEDs

BGARM14

14' Functional Length Arm

BGARM14LED

14' Functional Length Arm w/LEDs

BGARM18

18' Functional Length Arm

BGARM24

24' Functional Length Arm

Warranty

LIFTMASTER® 2 YEAR LIMITED COMMERCIAL WARRANTY

LiftMaster ("Seller") warrants to the first purchaser of this product, for the structure in which this product is originally installed, that it is free from defect in materials and/or workmanship for a period of 2 year commercial installation from the date of purchase [and that the PBG24DCW, PBG24DCG, CBG24DCW, CBG24DCG, IBG24DCW, IBG24DCG are free from defect in materials and/or workmanship for a period of 2 year commercial installation from the date of purchase]. The proper operation of this product is dependent on your compliance with the instructions regarding installation, operation, maintenance and testing. Failure to comply strictly with those instructions will void this limited warranty in its entirety.

If, during the limited warranty period, this product appears to contain a defect covered by this limited warranty, call 1-800-528-2806, toll free, before dismantling this product. Then send this product, pre-paid and insured, to our service center for warranty repair. You will be advised of shipping instructions when you call. Please include a brief description of the problem and a dated proof-of-purchase receipt with any product returned for warranty repair. Products returned to Seller for warranty repair, which upon receipt by Seller are confirmed to be defective and covered by this limited warranty, will be repaired or replaced (at Seller's sole option) at no cost to you and returned pre-paid. Parts will be repaired or replaced with new or factory-rebuilt parts at Seller's sole option.

ALL IMPLIED WARRANTIES FOR THE PRODUCT, INCLUDING BUT NOT LIMITED TO ANY IMPLIED WARRANTIES OF MERCHANTABILITY AND FITNESS FOR A PARTICULAR PURPOSE, ARE LIMITED IN DURATION TO THE 2 YEAR COMMERCIAL LIMITED WARRANTY PERIOD SET FORTH ABOVE [EXCEPT THE IMPLIED WARRANTIES WITH RESPECT TO THE PBG24DCW, PBG24DCG, CBG24DCW, CBG24DCG, IBG24DCW, IBG24DCG, WHICH ARE LIMITED IN DURATION TO THE 2 YEAR COMMERCIAL LIMITED WARRANTY PERIOD FOR THE PBG24DCW, PBG24DCG, CBG24DCW, CBG24DCG, IBG24DCW, IBG24DCG, AND NO IMPLIED WARRANTIES WILL EXIST OR APPLY AFTER SUCH PERIOD. Some states do not allow limitations on how long an implied warranty lasts, so the above limitation may not apply to you. THIS LIMITED WARRANTY DOES NOT COVER DAMAGE CAUSED BY IMPROPER INSTALLATION, OPERATION OR CARE (INCLUDING, BUT NOT LIMITED TO ABUSE, MISUSE, FAILURE TO PROVIDE REASONABLE AND NECESSARY MAINTENANCE, UNAUTHORIZED REPAIRS OR ANY ALTERATIONS TO THIS PRODUCT), LABOR CHARGES FOR REINSTALLING A REPAIRED OR REPLACED UNIT, OR REPLACEMENT OF BATTERIES. THIS LIMITED WARRANTY ALSO DOES NOT COVER ANY PROBLEMS CAUSED BY INTERFERENCE. ANY SERVICE CALL THAT DETERMINES THE PROBLEM HAS BEEN CAUSED BY ANY OF THESE ITEMS COULD RESULT IN A FEE TO YOU. UNDER NO CIRCUMSTANCES SHALL SELLER BE LIABLE FOR CONSEQUENTIAL, INCIDENTAL OR SPECIAL DAMAGES ARISING IN CONNECTION WITH USE, OR INABILITY TO USE, THIS PRODUCT. IN NO EVENT SHALL SELLER'S LIABILITY FOR BREACH OF WARRANTY, BREACH OF CONTRACT, NEGLIGENCE OR STRICT LIABILITY EXCEED THE COST OF THE PRODUCT COVERED HEREBY. NO PERSON IS AUTHORIZED TO ASSUME FOR US ANY OTHER LIABILITY IN CONNECTION WITH THE SALE OF THIS PRODUCT.

Some states and provinces do not allow the exclusion or limitation of consequential, incidental or special damages, so the above limitation or exclusion may not apply to you. This limited warranty gives you specific legal rights, and you may also have other rights, which vary from state to state and province to province.

Appendix



WARNING

To protect against fire and electrocution:

- DISCONNECT power (AC or solar and battery) BEFORE installing or servicing operator.

For continued protection against fire:

- Replace ONLY with fuse of same type and rating.

Wiring Diagram

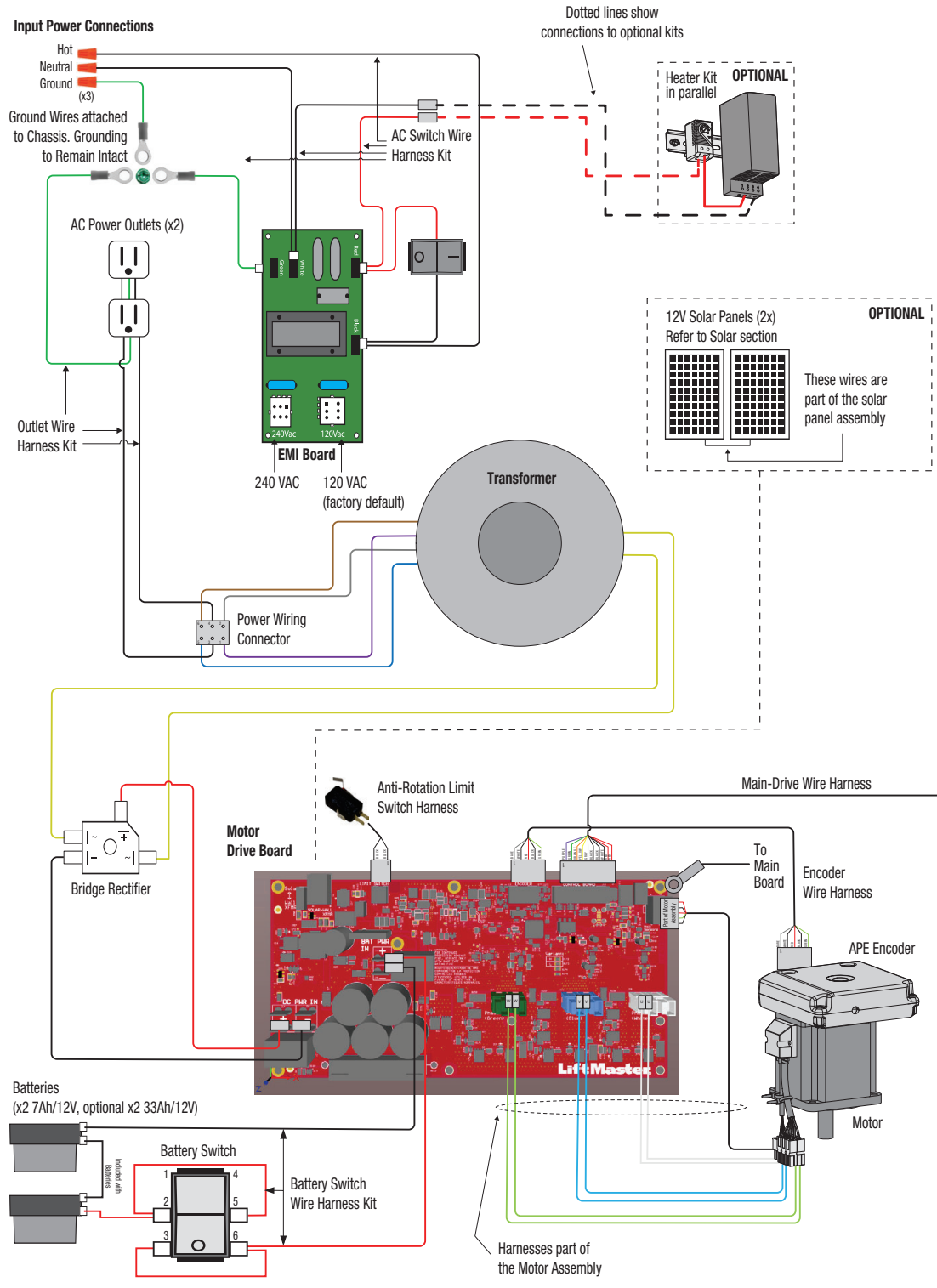

Appendix (continued)

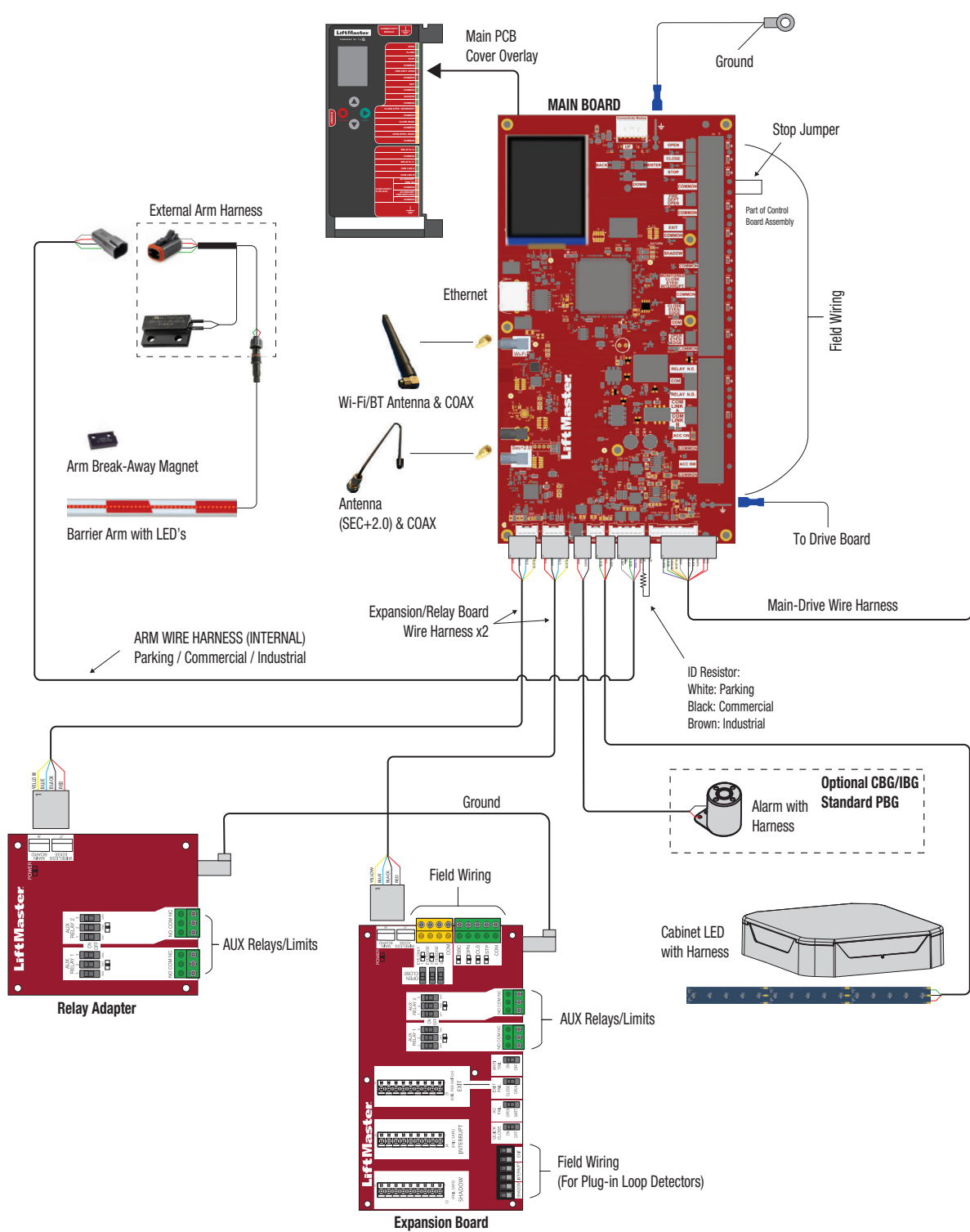

Appendix (continued)

Diagnostic Codes Table

Some codes are saved in the code history and some are not. If a code is not saved, it will briefly appear on the display as it occurs, then disappear.

LiftMaster System
 Installed System
 Informational
 External Obstruction Detection
 Inherent Obstruction Detecti

Code	Display Text	Meaning	Solution
8	8 - NO CONFIG	Configuration invalid or missing	The following settings were reset due to corruption of the previous configuration: <ul style="list-style-type: none"> • Reversal Force • Open and Close limit positions • Arm Length • Language • Arm and Cabinet LED • Buzzer • Operator Sync • Timer-To-Close • Power Fail • Arm Speed Perform Adjustment and Programming procedures to set the limits and adjust default settings. If issue persists, replace main control board.
14	14- NO LIMITS	Limit positions are not set or stored	Limit positions are not set due to being a new product or factory reset was performed. Enter Limit Setup mode and set the limits.
31	31- CTRL BOARD	Main control board has experienced an internal failure	Disconnect all power, wait 15 seconds, then reconnect power (reboot). If issue persists, replace main control board.
32	32 - VER MISMATCH	Main control board and motor drive board firmware versions are incompatible	Check FW Versions, replace main control board or motor drive board so that both boards have the same first (major) version number. If motor drive board version is not reported in display menu, verify motor drive board power and connection to control board. Disconnect all power, wait 15 seconds, then reconnect power (reboot). If issue persists, replace motor drive board.
34	34-APE ASM	Absolute Position Encoder error, not getting position information from encoder	Check Limit System Encoder and wiring connections. Disconnect all power, wait 15 seconds, then reconnect power (reboot). If issue persists, replace the Limit System Encoder.
35	35- OVER TRAVEL	Travel range exceeded	While learning limits, the arm position has exceeded the allowable travel range in the open direction. If still in Limit Learn menu, reverse direction of travel and check the following: <ul style="list-style-type: none"> • Verify that the counterbalance spring assembly is installed in the correct position for the intended arm handing. • Verify that the arm bracket was in the correct orientation when the hub bolts were torqued. • Inspect the spring protection switch connections and cable.
36	36- ID MISMATCH	Current Product ID does not match stored Product ID	Was the main control board just replaced? If so, erase limits, enter limit setup mode and set limits. If not, disconnect all power, wait 15 seconds, then reconnect power before changing product ID harness.
37	37- PRODUCT ID	Product ID failure	Unplug product ID harness then plug back in. Disconnect all power, wait 15 seconds, then reconnect power. If issue persists, replace product ID harness.
40	40- BATT OVERVOLT	Battery overvoltage	Measured battery voltage is too high. Check battery wiring.

Appendix (continued)

Code	Display Text	Meaning	Solution
41	BATT OVERCURR	Battery overcurrent	Possible short circuit. Check battery wiring. Make sure you do NOT have a single 12V battery on a 24V system.
42	42- NO BATTERY	No battery at boot up	Check battery connections and installation. Replace batteries if depleted to less than 20V on a 24V system. Make sure there is NOT a single 12V battery on a 24V system.
43	43- EXIT LOOP	Exit loop error	Failure or missing loop (SHORT or OPEN - LiftMaster Plug-in Loop Detector only). Check loop wiring throughout connection. May be a short in the loop, or an open connection in the loop. If loop detector has been removed, disconnect all power, wait 15 seconds, then reconnect power (reboot). Refer to LiftMaster Loop Detector Installation Manual to determine loop state.
44	44- SHADOW LOOP	Shadow loop error	
45	45- INTRPT LOOP	Interrupt loop error	
46	46- EDGE BATT LOW	Wireless edge battery low	Replace batteries in wireless edge.
47	47- MOTOR DRIVE	Motor Drive Fault	Check motor drive board connections. Disconnect all power, wait 15 seconds, then reconnect power (reboot). If issue persists, replace motor drive board.
48	48- HALL SENSOR	Hall Sensor Fault	Check motor and motor drive board connections. Disconnect all power, wait 15 seconds, then reconnect power (reboot). If issue persists, replace motor.
49	49- MOTOR COMM	Motor Drive Communications Fault	Verify motor drive board power and connection to main control board. Disconnect all power, wait 15 seconds, then reconnect power (reboot). If issue persists, replace motor drive
51	51- NO ARM	No Arm detected in Arm Bracket	<p>Arm is not installed/detected. Review:</p> <ul style="list-style-type: none"> • Verify the arm detection magnet is properly installed on the arm and aligned with the sensor on the arm bracket. • Verify the arm detection cable is connected to the arm bracket. • Verify the arm detection cable is connected to the arm bracket. • Verify the arm is securely installed within the arm bracket. • Inspect arm detection sensor, arm detection magnet, and cable for damage. <p>If issue persists, replace sensor, magnet, and arm cable.</p>
53	53- BROWNOUT	Brownout occurred	AC/DC board supply dipped below allowable level. Review power supply and wiring. If rebooting, ensure enough time for discharge of power to force a fresh boot.
54	54- OPERATOR COMM	Paired second operator communication error	Check the second operator for power. If OFF, restore power and try to run the system. If powered, unlearn paired operator and reconfigure paired operators.
61	61- CLOSE EYE HELD	MONITORED CLOSE EYES / INTERRUPT has been blocked for at least 3 minutes	Check wired input on main control board; check for alignment or obstruction; squeeze and release the edge and verify main control board edge LED changes; check for eye alignment or obstruction.
62	62- CLOSE EDGE	CLOSE EYES / EDGE has been blocked for at least 3 minutes	
63	63- OPEN EYE EDGE	OPEN EYES / EDGE has been blocked for at least 3 minutes	

Appendix (continued)

Code	Display Text	Meaning	Solution
64	64- CLOSE EYE INTRPT	Expansion board CLOSE EYE has been blocked for at least 3 minutes	Check wired input on expansion board; check for alignment or obstruction; squeeze and release the edge and verify main control board edge LED changes; check for eye alignment or obstruction.
65	65- CLOSE EYE EDGE	Expansion board CLOSE EYE / EDGE has been blocked for at least 3 minutes	
66	66- OPEN EYE EDGE	Expansion board OPEN EYE / EDGE has been blocked for at least 3 minutes	
67	67- WIRELESS EDGE	Wireless edge triggered extended time	Check wired input for wiring issue or obstruction; squeeze and release the edge and verify main control board edge LED changes.
68	68- WIRELESS EDGE	Wireless edge loss of monitoring	Check wireless edge inputs.
69	69- WIRELESS EDGE	Wireless edge triggered	If an obstruction occurred, no action required. If an obstruction did NOT occur, check inputs and wiring.
70	70- CLOSE EYE BLOCK	MONITORED CLOSE EYES / INTERRUPT triggered, causing reversal, preventing close, or resetting TTC	If an obstruction occurred, no action required. If an obstruction did NOT occur, check alignment, inputs, and wiring on main control board.
71	71- CLOSE EDGE	CLOSE EYE / EDGE triggered, causing reversal, preventing close, or canceling TTC	
72	72- OPEN EYE EDGE	OPEN EYE / EDGE triggered, causing reversal or preventing opening	
73	73- CLOSE EYE INTRPT	CLOSE EYE (Expansion Board) triggered, causing reversal, preventing close, or resetting TTC	If an obstruction occurred, no action required. If an obstruction did NOT occur, check alignment, inputs, and wiring on expansion board.
74	74- CLOSE EYE EDGE	CLOSE EYE / EDGE (Expansion Board) triggered, causing reversal and preventing close or canceling TTC	
75	75- OPEN EYE EDGE	OPEN EYE / EDGE (Expansion Board) triggered, causing reversal or preventing opening	
82	82- CLOSE EYE EDGE	Close input (EYE / EDGE) communication fault (expansion board)	Check the connections between the main control board and the expansion board.
83	83- OPEN EYE EDGE	Open input (EYE / EDGE) communication fault (expansion board)	

Appendix (continued)

Code	Display Text	Meaning	Solution
84	84- NON MONITORED	Non-monitored device detected on the wireless safety system	Non-monitored contact closure devices are not supported. Make sure connected devices are monitored. Check edges for proper orientation and resistive end cap connection.
85	85- CLOSE EYE EDGE EVENT	CLOSE EYE / EDGE triggered on paired operator, causing reversal and preventing close or canceling TTC	If an obstruction occurred, no action required. If an obstruction did NOT occur, check alignment, inputs, and wiring on paired operator.
86	86- OPEN EYE EDGE EVENT	OPEN EYE / EDGE triggered on paired operator, preventing opening	
87	87 - REMOTE FRC/STALL EVNT	Remote Force Limit/ RPM STALL detected on paired operator	If motor stopped while opening, check for excess weight on arm. Check for obstruction. If no obstruction, check that the mechanical assembly is engaged and free to move. See Limit, Speed, and Force Adjustment section. Check spring chart and ensure correct number of springs are installed.
90	90- LOW VOLT	Low Voltage Input to Motor Drive Fault	If error occurred while moving, test batteries with suitable battery tester. Replace batteries if worn out or failed. Always replace both batteries as a set. Do not mix old and new batteries or use mismatched types. If error occurred while stationary, verify incoming power meets voltage requirement of operator. Verify battery voltage is above 23V. Disconnect all power, wait 15 seconds, then reconnect power (reboot). If issue persists, replace power supply.
91	91- FORCE LIMIT	Force limit exceeded	If motor stopped while opening, check for excess weight on arm. Check for obstruction. If no obstruction, see Limit, Speed, and Force Adjustment section. Check spring chart and ensure correct number of springs are installed.
93	93- RPM STALL	RPM / STALL detected	If motor stopped while opening, check for excess weight on arm. Check for obstruction. If no obstruction, check the motor wiring and Limit System Encoder. Check spring chart and ensure correct number of springs are installed.
95	95- DRIVE TEMP	Motor Drive Board temperature too high	Check ambient temperature and ensure it is within the operational ratings of the operator. Check that dust or other debris is not built up inside cabinet. Replace motor drive board if issue persists.
96	96- DRIVE CURR	Motor Drive Board current too high	Check connections to motor drive board. Power cycle and retry. Replace motor drive board if issue persists.
97	97- BATT DPLTD	Battery depleted (below 23 V)	Battery voltage has been drained to critical level. Restore AC or solar power and ensure battery recharges properly. Test batteries with suitable battery tester. Replace batteries if worn out or failed. Always replace both batteries as a set. Do not mix old and new batteries or use mismatched types.

Appendix (continued)

Code	Display Text	Meaning	Solution
98	98- AC PWR LOSS	AC power loss, system operating on battery	Incoming power loss. Review: <ul style="list-style-type: none"> • Input voltage. • Circuit breaker is not tripped. • AC Switch inside cabinet is not tripped. • Transformer connections to EMI board connectors. If voltage is out of specification, consult an electrician.
99	99- MAINT DUE	Maintenance Cycle count reached, service operator	Complete maintenance and reset maintenance cycle counter.
100	100 - CLOSE EYES NP	CLOSE EYES/INTERRUPT device not detected	A learned Close Eye was not detected on main control board MONITORED CLOSE EYES / INTERRUPT input. If device was removed, perform Relearn All Monitored Eyes and Edges. Check device wiring.
101	101 - CLOSE EDGE NP	CLOSE EDGE device not detected	A learned Close Edge was not detected on main control board CLOSE EDGE input. If device was removed, Relearn All Monitored Eyes and Edges. Check device wiring.
102	102 - OPEN EYES NP	OPEN EYES/EDGE device not detected	A learned Open Eye or Edge was not detected on main control board OPEN EYES/EDGE input. If device was removed, Relearn All Monitored Eyes and Edges. Check device wiring.

Appendix (continued)

Removing the Spring Tension for IBG

ATTENTION: The steps below must be used to safely remove springs from an IBG operator. They allow the spring assembly to disengage from the gearbox while it is still mounted in place.

1. Locate the three bolts that attach the spring assembly to the gearbox with three nuts (two on the top and one on the bottom), see the pictures below. Using a socket wrench and extension to avoid accidental contact with the loaded springs inside the cabinet enclosure, loosen each nut all the way until the end of bolt. Do NOT fully remove these nuts yet.

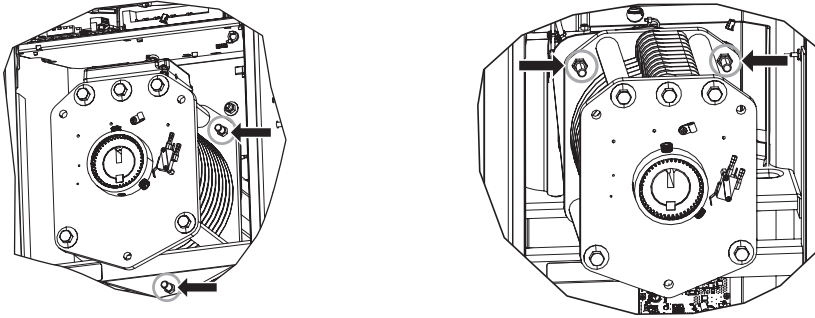

NOTE: The spring protection limit switch harness does NOT need to be removed during this operation.

2. Use a pry bar between the spring assembly and gearbox around three mounting bolts to disengage it from the gearbox, avoiding contact with the springs and center hub. Rotate and repeat priming locations until spring assembly is disengaged. Do not use hands or body to release tension.

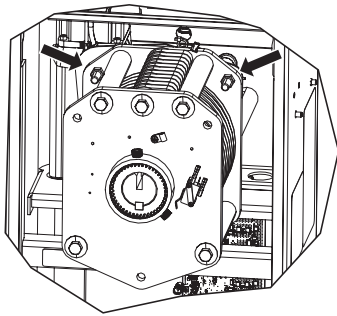

3. Verify the springs are loose before removing the three nuts completely. The shaft of the spring assembly should be able to freely move a few degrees when nudged with a screwdriver if the springs are disengaged.

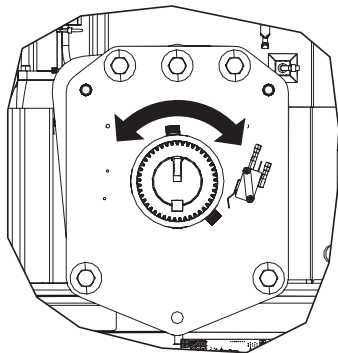

4. If the springs do not disengage repeat step 2, if that is unsuccessful call technical support.

WARNING

If these steps do not work to remove the spring tension, contact Technical Support for instruction on alternate method. DO NOT USE EXCESSIVE FORCE TO DISENGAGE SPRINGS FROM GEARBOX. SEVERE INJURY MAY OCCUR.

Appendix (continued)

Reverse the Spring Handing for IBG

PRIOR TO REMOVING SPRING CARRIER BOLTS, ENSURE SPRING TENSION IS RELEASED. SEE PREVIOUS SECTION ABOVE FOR MORE DETAIL.

Remove the counterbalance spring assembly by removing three nuts that attach the counterbalance spring assembly to the gearbox. Take care not to damage the spring protection limit switch harness.

1. Rotate the counterbalance spring assembly 180° so that the two end plates swap position. The spring arrows should still be on the top of the assembly after rotating.
2. Install the three nuts again to secure the counterbalance spring assembly to the gearbox. Torque the 3 nuts fastening the counterbalance spring assembly to 18-20 ft-lb.

NOTE: Removing and reinstalling springs in the opposite direction does NOT work to switch the handing of the unit due to the spring protection limit switch functionality. The entire counterbalance spring carrier must be reversed to change the spring handing. The spring protection limit switch stays in the same position on the hub during this process.

Modify the Spring Count for IBG

1. Remove the hub by loosening the two set screws and spring protection limit switch bolt if necessary and sliding it off (see image A and B).
2. Remove the end plate by removing the five bolts (see image C and D). If the plate contains the spring protection limit switch, ensure that it is not damaged or unplugged. If it does become unplugged, ensure that it is rewired as a Normally Closed (NC) switch. See "Spring protection limit switch" above for more details.
3. Remove unneeded springs and spacers by sliding them off (see image E).
4. Add retention collars (provided in the pack in bag) in place of the removed springs. These retention collars prevent the springs from sliding out of place during operation (see image F).
5. Add the washer before and after endplate is placed (see image F).
6. Replace end plate and tighten the five end plate bolts and beveled washers to **24-25 ft-lb** (see image C).
7. Pay attention to direction of the beveled washers (see image G).
8. Replace hub and tighten the two set screws to **25ft-lb** (see image B).

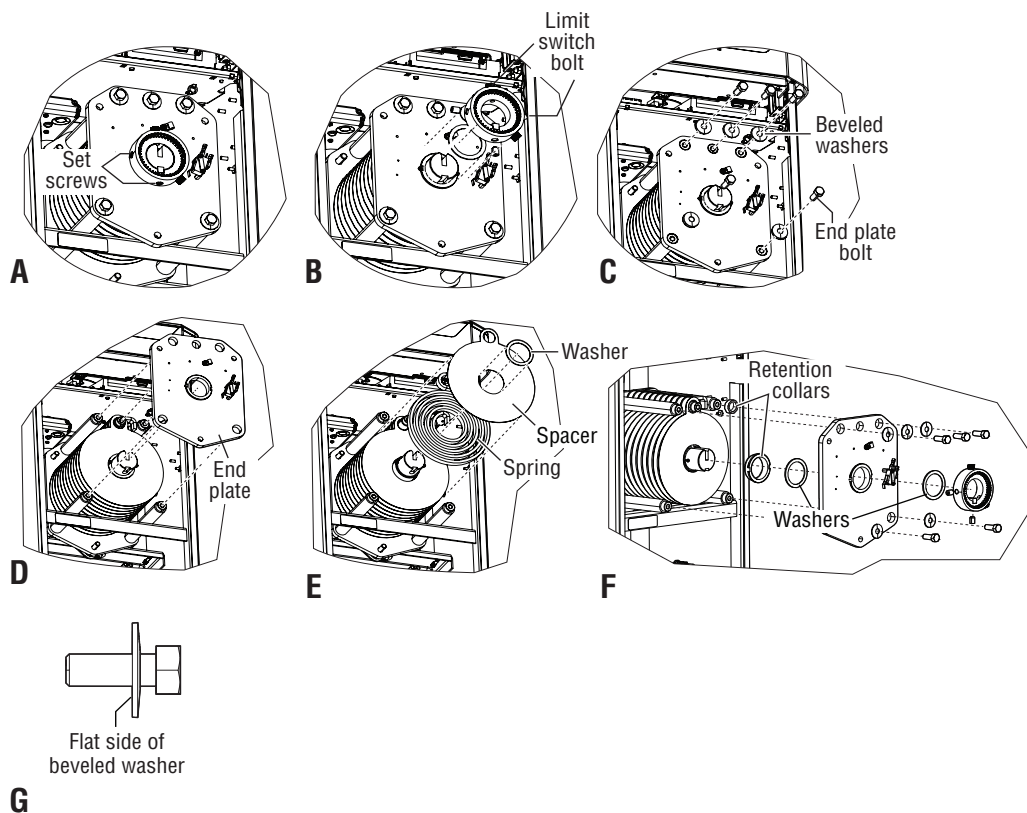

Contact Information

LiftMaster.com

Visit LiftMaster.com to locate a professional installing dealer in your area.

LiftMaster Partner Portal:

Partner.LiftMaster.com/login

LiftMaster Training Academy:

LiftMasterTraining.com

For any additional questions, or support please contact LiftMaster Customer Service/Support at:

800-528-2806

Mon-Fri 5:00 am to 6:00 pm MST

For troubleshooting and support content/videos:



<https://support.partner.liftmaster.com/s/gate-operators/barrier-gates/techna>