

# **SW - C**

**RESIDENTIAL / COMMERCIAL  
SWING GATE OPERATOR**

**MADE IN U.S.A.**

ROTARY GATE SYSTEMS, INC.

ALL RIGHTS RESERVED 2025

REV. 4.2

1-877-331-4RGS (4747)

# INTRODUCTION

---

The Rotary Gate Systems SW-C swing gate operator has been designed to be the most reliable and easiest to install product in its field. The straight forward, compact design ensures that this will be the operator of choice for installer, service technicians and customer alike.

The SW-C features include:

- Powerful 1594:1 High torque 24 volt DC gearmotor
- Built in battery backup power
- Full systems capable controller
- Built in Instant reversing Sensor
- Continuous duty operation when used on properly installed gates
- Input for non-contact secondary entrapment protection device

In addition, the SW-C offers these features not found in any other operator:

- Compact design blends better with surroundings than pad mount operators
- No concrete pad to pour and wait to set up
- No anchors to install
- Operator mounts to gate support post in 15 minutes or optional positioning in standard pad-mount location
- Weatherproof limit switches housed inside operator with easy to use external adjustments
- Durable powder coated parts provide years of attractive service

**THIS GATE OPERATOR CONFORMS WITH THE REQUIREMENTS FOR  
UL325, 7TH EDITION AND REQUIRES THE INSTALLATION OF  
APPROPRIATE 10K MONITORED OBSTRUCTION DETECTION DEVICES.**

## Table of contents

---

<b>Safety Information and Warnings</b> .....	4	<b>Dual Gate Installations</b> .....	20
<b>Wiring specifications</b> .....	4	<b>Gate Operation</b> .....	20
Regulatory warnings		Open button	
<b>Earth Ground</b> .....	4	Close button	
<b>Pre-Installation Information</b> .....	5	Stop button	
Gate operator classifications Approved		Single input	
obstruction detection devices		Fire department input	
<b>Safety Information</b> .....	6	Open obstruction	
Safety device guidelines		Close obstruction	
<b>Access Control Devices</b> .....	6	Reverse input	
<b>Installation</b> .....	7	Open loop	
Mounting Control Box		Reverse loop	
Conduits		Shadow/reset loop	
Mounting the Operator		<b>Operator Indications</b> .....	21
<b>Connecting the Operator</b> .....	8	Power-up display	
		Idle condition	
Control Box Layout .....	9	Last gate position/condition	
J1 Terminal Descriptions.....	10	Pre-start delay	
<b>Indicator Descriptions</b> .....	11	Reverse delay	
<b>Terminal Descriptions</b> .....	12	Run timer	
<b>Operator Accessory Connections</b> .....	13	<b>Error Indications</b> .....	21
<b>Basic Controller Programming</b> .....	14	Entrapment	
Programming overview		COMM LINK connection failure	
Entering programming mode		MGT obstacle transmitter trouble	
Exiting programming mode		Maximum run time exceeded	
Programming keystrokes		<b>Troubleshooting</b> .....	22
Left or right hand operation		Contacting technical support	
Dual gate enable		Operator fails to start	
Auto close timer		Motor operates, but gate does not move	
Run alarm and pre-start alarm		Motor sounds like it is working harder than normal	
Maximum open direction current setting		Limit switch getting out of time	
Maximum close direction current setting		Gate stopping part way open or closed	
<b>Advanced Controller Programming</b> .....	16	Gate staying open with automatic system	
Entering advanced programming mode		How to order replacement parts	
Maximum run time		<b>Model SW-C</b> .....	22
Single button input setup		Battery maintenance	
Stagger mode		<b>Preventative Maintenance</b> .....	22
Stagger delay time		General	
Auxiliary relay mode		Lubrication	
Reverse delay time		Six-month preventative maintenance	
Low power mode		<b>FCC Notice</b> .....	22
Power failure mode		<b>Warranty</b> .....	23
Soft start/stop duration			
Reset cycle count			
Maintenance alert trigger			
Mid-travel stop position			
Motor type selection			
Radio enable			
Antenna installation			
Radio transmitter learn			
Radio transmitter delete			
MGT obstacle transmitter learn			
MGT obstacle transmitter delete			
Reset controller to factory defaults			

## Safety Information and Warnings

THE FOLLOWING FORMATS ARE USED FOR SAFETY NOTES IN THESE INSTRUCTIONS.

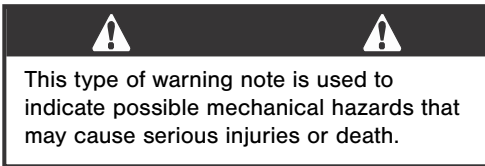
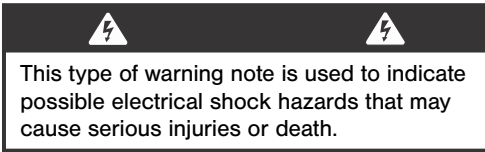
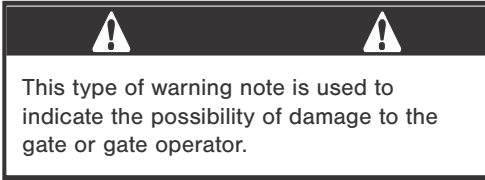

## Wiring Specifications

Refer to the following steps for details on power and accessory wiring for the operator.



**USE COPPER WIRE ONLY!**

### AC Power Wiring

1. Connect power in accordance with local codes. The green ground wire must be properly connected.
2. Wire insulation must be suitable to the application.
3. Electrical outlets are supplied in all models for convenience with occasional use or low power consumption devices only.

### DC Control and Accessory Wiring

1. All control devices are 24 VDC, which can be run up to 2000 feet with 14 AWG wire.
2. Control wiring must be run in a separate conduit from power wiring. Running them together may cause interference and faulty signals in some accessories
3. A three-wire shielded conductor cable is required to connect two operators together for dual operation. You must use Beldon 8760 Twisted Pair shielded Cable (or equivalent) only. See Page 21 for details of this connection.

**Note: The shield wire should be connected in both the operators.**

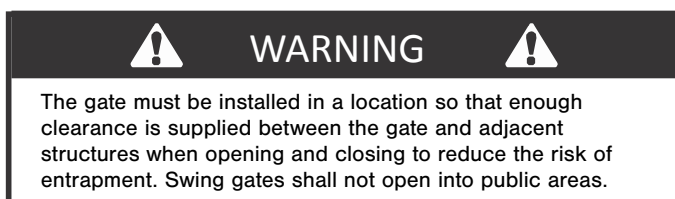

## Regulatory Warnings

Read the following before beginning to install this swing gate operator:

**IMPORTANT INSTALLATION SAFETY INSTRUCTIONS**

**WARNING**

**TO REDUCE THE RISK OF SEVERE INJURY OR DEATH TO PERSONS, REVIEW THESE INSTALLATION SAFETY STEPS BEFORE PROCEEDING**

1. READ AND FOLLOW ALL INSTALLATION INSTRUCTIONS.
2. ALL ELECTRICAL CONNECTIONS TO THE POWER SUPPLY MUST BE MADE BY A LICENSED ELECTRICIAN AND MUST OBSERVE ALL NATIONAL AND LOCAL ELECTRICAL CODES.
3. A separate power-disconnect switch should be located near the operator so that primary power can be turned off when necessary.
4. Install the enclosed warning signs on both sides of the gate. A minimum of two (2) warning signs shall be installed, one on each side of the gate where easily visible.
5. Never reach between, through or around the fence to operate the gate.
6. Never connect a button station within reach of the gate or on the side of the gate operator.
7. Do not adjust the operator controller's current sensing feature too high. It should be adjusted high enough to keep the gate from falsely triggering the sensing, but no higher than necessary for the gate to operate. **DO NOT DEFEAT THE PURPOSE OF THIS FUNCTION!**
8. You must install all required safety equipment.
9. UL325 Compliance requires the use of contact edges of photoelectric controls on all automatic or remotely-controlled gate operators.
10. The operator is intended for installation only on gates used for vehicles. Pedestrians must be supplied with a separate access opening. The pedestrian access opening shall be designed to promote pedestrian usage. Locate the gates such that persons will not come into contact with the vehicular gate during the entire path of travel of the vehicular gate.

## Earth Ground

Install a ground rod and connect it to the operator's control box in every gate operator installation. A good earth ground is necessary to allow the controller's built-in surge and lightning protection circuitry to work effectively.

All ROTARY GATE SYSTEMS gate operators are supplied with a power disconnect switch to turn on and off the power available to the operators. Incoming power should be brought into the operator control box and connected to the appropriate terminals on the J1 terminal block

**\*NOTE: Do not splice the ground wire. Use a single piece of solid copper 12 AWG wire between the ground rod and the operator.**

1. Install an 8-foot long copper ground rod next to the operator control box.
2. Use a clamp to connect a solid copper 12 AWG ground wire to the ground rod.
3. Route the ground wire to the operator control box.
4. Connect the ground wire to the operator's control box.

## GATE OPERATOR CLASSES

All gate installations can be divided into one of four different classifications, depending on their design and usage. Install this gate operator only when the operator is appropriate for the construction and usage class as defined below:

### **Class I Residential Vehicular Gate Operator**

A vehicular gate operator intended for use in a home or for one to four single family dwellings with a common garage or parking area associated with these dwellings.

### **Class II Commercial/General Access Vehicular Gate Operator**

A vehicular gate operator intended for use in a commercial location or building such as a multi-family housing unit of five or more single family units, hotel, retail store or other building servicing the general public.

### **Class III Industrial/Limited access Vehicular Gate Operator**

A vehicular gate operator intended for use in an industrial location or building such as a factory or loading dock area or other location not intended to service the general public.

### **Class IV restricted Access Vehicular Gate Operator**

A vehicular gate operator intended for use in a guarded industrial location or building such as an airport security area or other restricted access locations not servicing the general public, in which unauthorized access is prevented via supervision by security personnel.

## APPROVED OBSTRUCTION DETECTION DEVICES

The following contact or non-contact obstruction detection devices have been tested and approved for use with this swing gate operator as part of a UL325 compliant installation:

### **Contact Edges**

Miller Safety Edges MGO20, MGR20, MGS20, ME120

### **Photo eyes**

MMTC EMX Model IRB-MON (Thru Beam), MMTC Omron Model E3K-R10K4-10R

In addition, the following safety devices are recommended for use with the SW-C swing gate operator:

EMX IRB-RET Photocell (Retro-reflective)  
EMX Wireless Edge Link WEL-200T / WEL-200R  
Enforcer E931-S50RRGQ Photocess (Retro-reflective)  
Enforcer E960-G90GQ Twin Beam (Thru Beam)  
Miller Edge Prime Guard Photocell (Thru Beam)  
Miller Edge R-Band Wireless Edge P/N: RB-G-RX10 & RB-TX10  
Optex OVS-50TNR Hybrid Photoelectric 50' Dual Beam  
ASO Contact Edges

# Safety Information

---

Gate system designers, sellers, installers, technicians, and users should familiarize themselves with the proper layout designs required to ensure the safe operation of the gates and any accessories associated with them. Any gate system design must include safety devices of sufficient quantity and placement to protect the customer, the general public and technicians working on the system from potential harm. Use the following guidelines to help with the design of the gate layout.

- Always install safety sensors (magnetic loops, photo beams, safety edges) in the proper locations to eliminate any potential entrapment points.
- Always install at least 2 WARNING SIGNS (one on each side of the gate in a clearly visible location). 6
- Before installing the gate and operator, verify:
  - The gate design is appropriate for the site and type of usage
  - The gate operator is appropriate for the type of gate and usage level.
  - The appropriate controls and safety devices have been included in the layout of the system.
  - A separate pedestrian gate has been included in the gate layout in a location safe from contact with the vehicular gate when it is in the full open position.
- Any controls used to open the gate must be located at least 7' from any portion of the moving gate to keep a user from attempting to reach through, under, over, or around the gate to activate the control.

## Safety Device Guidelines

---

### *Loops*

Any type of installation which includes the use of the AUTOMATIC CLOSE TIMER feature on the control board will also require the use of at least one non-contact safety reversing device (embedded magnetic vehicle loop with detector). This loop should be installed in addition to photo beams and should be located so as to allow the vehicle to trip the photo beam before leaving the field of the loop

### *Photo Beams*

Any type of installation which includes the use of the AUTOMATIC CLOSE TIMER feature on the control board will also require the use of at least one non-contact safety reversing device (infrared photo beam). This photo beam should be installed parallel to the closed gate and 21" - 27.5" high off the roadway.

### *Safety Edges*

Any type of installation which includes the use of the AUTOMATIC CLOSE TIMER feature on the control board may require installation of safety edges in appropriate quantities and locations to ensure that all Entrapment Zones are sufficiently protected

## Access Control Devices

The SW-C is compatible with any type of access control device which provides a dry contact relay for activation.

## Installation

---

### Mounting Control Box

#### General

The SW-C control box is separate from the operator to allow for easy mounting in a convenient location and to allow for locating it on columns or walls up to 25 feet away from the gate with the proper wire.

#### Conduits

The SW-C control box provides knock outs in the bottom of the box for installation of conduit. Please note that the batteries are also located in the bottom of the control box and install conduits accordingly.

If mounting the SW-C control box remotely from the gate, run wires from the control box for the operator motor, limit switches, internal brake, photo beams, loops and opening accessories. AC power and low voltage wiring should always be installed in separate conduits.

### Mounting the Operator

The SW-C can mount directly to the gate support post if space allows or it can be attached to the column or mounted to a separate post in the position of a traditional pad-mount operator.

Set the gate support post as normal. A schedule 80 steel post or ¼" wall aluminum post is recommended. A channel may also be used to attach to a column.

Once the gate is mounted and checked for free movement, the gate operator can be mounted in the desired location and configuration.

Determine the desired vertical location on the gate for attachment of the gate arm. Since the operator doesn't have to be mounted to a concrete pad, there is no set height for the gate arm attachment to the gate.

Separate the 1/2" x 4" Mounting Plate from the operator by removing (4) 3/8 nuts with 9/16 wrench. Use this plate as a template to drill mounting holes in the post where the operator will be attached.

Drill 5/16" holes in these locations and then tap for 3/8-16 bolts (if bolting to the post) or drill clearance hole through for 3/8 bolt.

Once the Mounting Plate is secure, re-attach the operator. You are now ready to attach the wires from the operator to the control box. SEE SUPPLEMENT FOR ATTACHING GATE ARM, SETTING LIMIT SWITCHES AND WIRING TO CONTROL BOX.

### Installing Accessories

Refer to Figures 6 and 11 in the Installation Manual for Accessory Connections.

CONTROLLER FEATURES

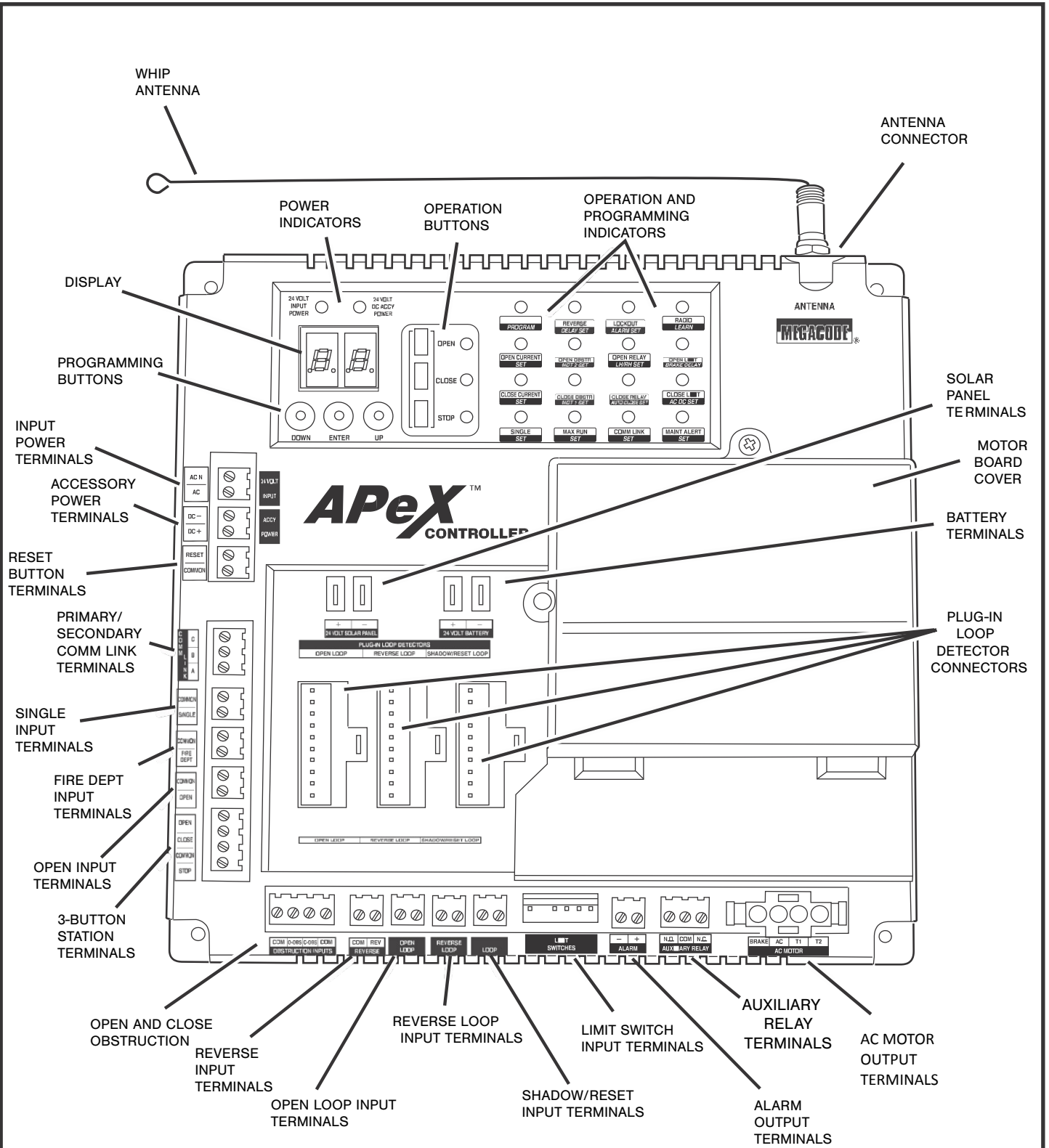

Figure 6. Controller Features

# Indicator Descriptions

INDICATOR DEFINITION		INDICATION WHEN LIT DURING NORMAL OPERATION	INDICATION WHEN LIT DURING PROGRAMMING
OPERATION	PROGRAMMING		
24 VOLT INPUT POWER		LOW VOLTAGE AC POWER IS PRESENT	
24 VOLT DC ACCY POWER		LOW VOLTAGE DC POWER IS PRESENT	
OPEN		OPEN SIGNAL PRESENT FROM THE INTERNAL RECEIVER OR AN EXTERNAL DEVICE CONNECTED TO THE OPEN INPUT TERMINAL	
CLOSE		CLOSE SIGNAL IS PRESENT FROM A DEVICE CONNECTED TO THE CLOSE INPUT TERMINAL	
STOP		STOP INPUT TERMINAL IS OPEN AND NOT CONNECTED TO COMMON	
PROGRAM			CONTROLLER IS IN PROGRAMMING MODE
REVERSE	DELAY SET	SIGNAL FROM REVERSING DEVICE IS PRESENT	SET REVERSE DELAY TIME
LOCKOUT	ALARM SET	CONTROLS AND OPERATOR ARE LOCKED OUT BECAUSE OF EXISTING TROUBLE CONDITION	SET RUN ALARM AND PRE-START ALARM
RADIO	LEARN	BUILT-IN RECEIVER IS DETECTING A RADIO SIGNAL FROM A REMOTE CONTROL	TRANSMITTERS CAN BE ENTERED INTO MEMORY (UP TO 40 TRANSMITTERS)
OPEN CURRENT	SET	MOTOR CURRENT HAS EXCEEDED THE OPEN CURRENT SETTING WHILE OPENING	SET MAXIMUM OPEN CURRENT
OPEN OBSTR	MGT 2 SET	OPEN OBSTRUCTION TERMINAL CONNECTED TO COMMON BY BEAM OR SAFETY EDGE, OR SIGNAL FROM MGT OBSTACLE TRANSMITTER	SET MGT #2 FUNCTION
OPEN RELAY	LH/RH SET	OPEN RELAY IS ACTIVATED	SET LEFT-HAND RIGHT-HAND OPERATION
OPEN LIMIT	BRAKE DELAY	OPEN LIMIT SWITCH IS ACTIVATED	
CLOSE CURRENT	SET	MOTOR CURRENT HAS EXCEEDED THE CLOSE CURRENT SETTING WHILE CLOSING	SET MAXIMUM CLOSE CURRENT
CLOSE OBSTR	MGT 1 SET	CLOSE OBSTRUCTION TERMINAL CONNECTED TO COMMON BY BEAM OR SAFETY EDGE, OR SIGNAL FROM MGT OBSTACLE TRANSMITTER	SET MGT #1 FUNCTION
CLOSE RELAY	AUTO CLOSE SET	CLOSE RELAY IS ACTIVATED	SET AUTO-CLOSE TIME
CLOSE LIMIT	AC DC SET	CLOSE LIMIT SWITCH IS ACTIVATED	SET MOTOR TYPE
SINGLE	SET	SINGLE TERMINAL CONNECTED TO COMMON BY AN EXTERNAL PUSHBUTTON OR RADIO	SET SINGLE BUTTON INPUT FUNCTION
MAX RUN	SET	MAXIMUM RUN TIMER HAS BEEN EXCEEDED	SET MAXIMUM RUN TIME
COMM LINK	SET	DUAL OPERATOR CONNECTION DETECTED, BLINKS IF CONNECTION HAS FAILED	
MAINT ALERT	SET	MAINTENANCE IS REQUIRED ON OPERATOR	SET MAINTENANCE ALERT CYCLE COUNT

## APEX FUNCTION DISPLAY INDICATIONS

"RL" LEFT OR RIGHT HAND OPERATION	"RT" MAXIMUM RUN TIMER	"CP" CONSTANT PRESSURE MODE	"TL" LEARN TRANSMITTERS
"PM" SINGLE OR DUAL GATE	"SB" SINGLE BUTTON INPUT SETUP	"SP" SHADOW LOOP OPEN INHIBIT	"TD" DELETE TRANSMITTERS
"AC" AUTO CLOSE TIMER	"SM" STAGGER MODE	"CT" RESET CYCLE COUNT	"ML" LEARN MGT TRANSMITTERS
"RP" RUN ALARM PRE-START ALARM	"ST" STAGGER TIME	"MA" MAINTENANCE ALERT TRIGGER	"MD" ERASE MGT TRANSMITTERS
"OC" MAXIMUM OPEN CURRENT	"AR" AUXILIARY RELAY MODE	"MT" MID-TRAVEL STOP POSITION	"MO" MOTOR TYPE SELECTION
"CC" MAXIMUM CLOSE CURRENT	"RD" REVERSE DELAY TIME	"AT" ANTI-TAILGATE ENABLE	"CL" RESET TO FACTORY DEFAULTS
"AD" ADVANCED PROGRAMMING	"BD" BRAKE DELAY TIME	"RA" RADIO ENABLE	"OT" OBSTRUCTION DETECTION TYPE, b1, b2
"OO" OPEN OBSTRUCTION INPUT ACTIVE	"CO" CLOSE OBSTRUCTION INPUT ACTIVE	"RO" REMOTE OPEN OBSTRUCTION ACTIVE	"RC" REMOTE CLOSE OBSTRUCTION ACTIVE
"MM" MGT MONITORING FUNCTION			

# J1 TERMINAL DESCRIPTIONS

<b>J 1</b>			
<b>A C H O T</b>		<b>INPUT POWER</b>	<b>INCOMING 110 VAC POWER</b>
<b>A C N E U</b>			<b>INCOMING 110 VAC NEUTRAL</b>
<b>G R O U N D</b>			<b>INCOMING 110 VAC GROUND</b>
<b>M O T O R B L K</b>		<b>OPERATOR CONNECTIONS</b>	<b>BLACK MOTOR WIRE (WHITE JACKET)</b>
<b>M O T O R R E D</b>			<b>RED MOTOR WIRE (WHITE JACKET)</b>
<b>B R A K E B L K</b>			<b>BLACK BRAKE WIRE (BLACK JACKET)</b>
<b>B R A K E R E D</b>			<b>RED BRAKE WIRE (BLACK JACKET)</b>
<b>24 V D C -</b>		<b>24 DC PWR</b>	<b>- 24 VDC ACCESSORY POWER</b>
<b>24 V D C +</b>			<b>+ 24 VDC ACCESSORY POWER</b>
<b>Y E L L O W</b>		<b>LIMIT SWITCHES</b>	<b>YELLOW LIMIT SWITCH WIRE (BLACK JACKET)</b>
<b>C O M</b>			<b>WHITE WIRE COMMON (BLACK JACKET)</b>
<b>B L U E</b>			<b>BLUE LIMIT SWITCH WIRE (BLACK JACKET)</b>

# Operator Accessory Connections

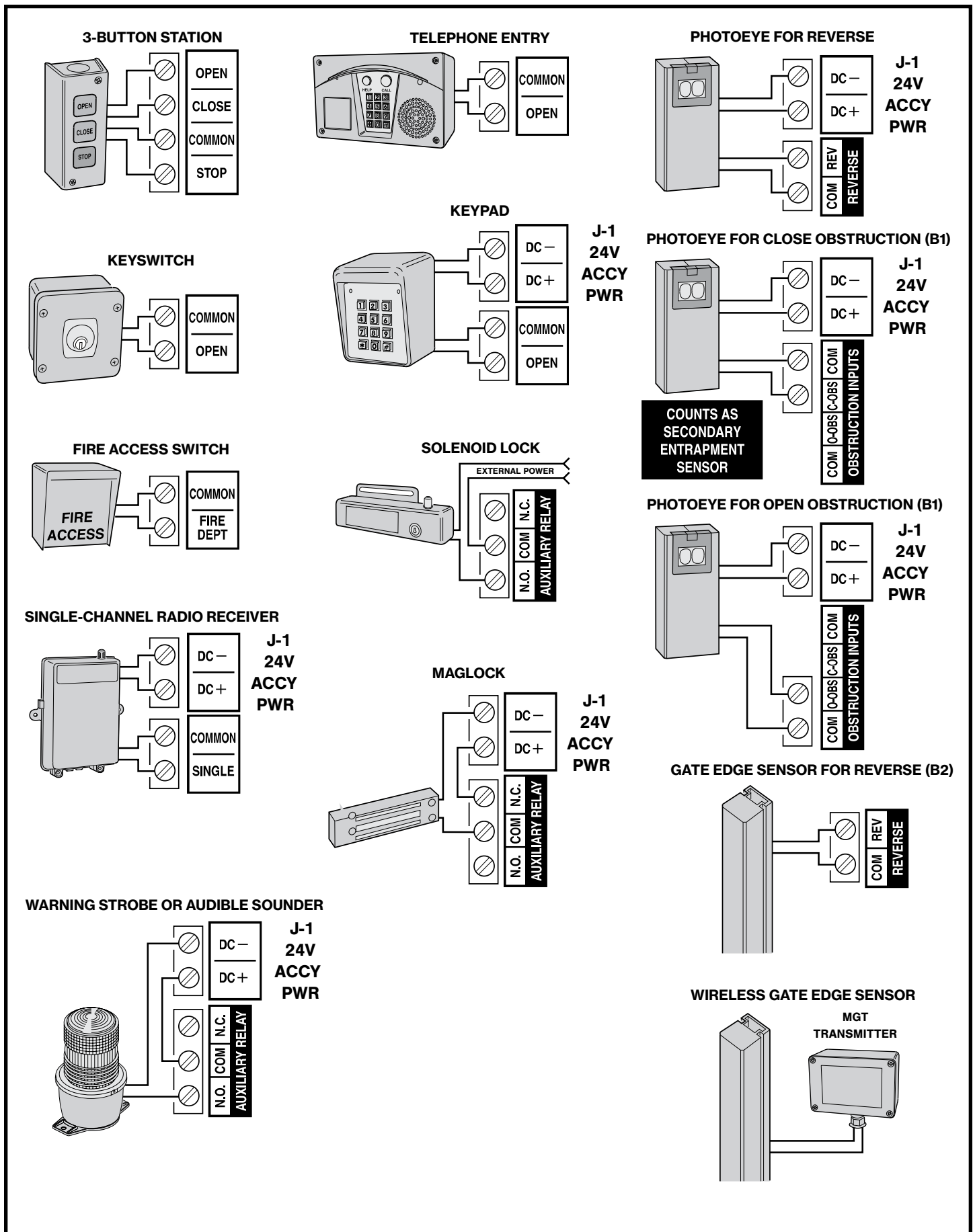

Figure 11. Operator Accessory Connections

## TERMINAL DESCRIPTIONS

TERMINAL	DESCRIPTION	FUNCTION
AC N AC	24 VOLT DC INPUT	FACTORY CONNECTED TO 24 VDC FROM CONTINUOUS DUTY DC POWER SUPPLY
DC-  DC+ RESET COMMON	ACCESSORY POWER  RESET BUTTON	PROVIDES 24VDC POWER FOR ACCESSORIES. DO NOT CONNECT ACCESSORIES WHICH REQUIRE COMBINED TOTAL MORE THAN .5 AMPS CURRENT DRAW WHEN ACTIVATED.  FACTORY CONNECTED TO THE CONTROL BOX RESET BUTTON
C B A COMMON	COMM LINK	FOR 3-WIRE NETWORK CONNECTION TO SECOND OPERATOR IN DUAL GATE INSTALLATIONS
SINGLE COMMON FIRE DEPT	SINGLE BUTTON INPUT  FIRE DEPT INPUT	CONNECT TO NORMALLY OPEN CONTACT FOR SINGLE BUTTON OPERATION. ALTERNATES BETWEEN OPEN-CLOSE OR OPEN-STOP-CLOSE-STOP DEPENDING ON "SB" PROGRAMMING  CONNECT TO NORMALLY OPEN SWITCH IN FIRE BOX FOR FIRE DEPARTMENT ACCESS. <b>WARNING:</b> A SIGNAL ACROSS THESE CONTACTS CAUSES AN EN04 ERROR AND LOCKS THE GATE IN THE OPEN POSITION UNTIL RESET
COMMON OPEN	OPEN INPUT	CONNECT TO NORMALLY OPEN DEVICES (KEYPAD, CARD READER, KEYSWITCH, TELEPHONE ENTRY SYSTEM) TO OPEN THE GATE. A CONSTANT OPEN INPUT WILL OVERRIDE THE MIDTRAVEL STOP AND HALT THE AUTO CLOSE TIMER UNTIL RELEASED.
OPEN CLOSE COMMON STOP	3-BUTTON STATION INPUT	CONNECT TO 3-BUTTON STATION FOR OPEN-CLOSE-STOP CONTROL. A CONSTANT OPEN INPUT WILL OVERRIDE THE MID-TRAVEL STOP AND HALT THE AUTO CLOSE TIMER UNTIL RELEASED. INTERRUPTING THE STOP-COMMON CIRCUIT WILL HALT GATE OPERATION.
COM O-OBS	OBSTRUCTION INPUTS	CONNECT TO NORMALLY OPEN DEVICES (GATE EDGE, PHOTO BEAM) TO DETECT AN OBSTRUCTION DURING OPENING. WHILE GATE IS IN MOTION, ANY OPEN OBSTRUCTION SIGNAL WILL CAUSE THE GATE TO STOP, REVERSE A SHORT DISTANCE, AND THEN STOP. AT THIS TIME, THE AUTO CLOSE TIMER IS DISABLED AND A RENEWED INPUT WILL BE REQUIRED TO START THE GATE AGAIN. SHOULD THE GATE BE RESTARTED AND THE OBSTRUCTION SIGNAL OCCUR AGAIN PRIOR TO REACHING A LIMIT, THE GATE WILL STOP AGAIN, LOCK OUT AND SOUND THE EMERGENCY ALARM, REQUIRING THE "RESET" BUTTON TO BE ACTIVATED.
C-OBS COM COM		FUNCTIONS THE SAME AS THE OPEN OBSTRUCTION, EXCEPT IN THE CLOSING DIRECTION
REV OPEN LOOP	REVERSE	CONNECT TO NORMALLY OPEN DEVICES TO CAUSE A REVERSAL WHEN THE GATE IS TRAVELING CLOSED. THE GATE WILL REVERSE TO THE FULL OPEN POSITION.
OPEN LOOP REVERSE LOOP	OPEN LOOP	CONNECT TO OPEN LOOP/FREE EXIT LOOP. THE GATE WILL OPEN WHEN THE LOOP IS TRIGGERED, AND REMAIN OPEN AS LONG AS THE LOOP REMAINS ACTIVATED.
REVERSE LOOP SHADOW/RESET LOOP	REVERSE LOOP	CONNECT TO REVERSE LOOP. TRIGGERING THE LOOP WHEN THE GATE IS CLOSING WILL CAUSE A REVERSAL IN GATE TRAVEL TO THE OPEN LIMIT SWITCH.
SHADOW/RESET LOOP	SHADOW/RESET LOOP	CONNECT TO SHADOW/RESET LOOP TO KEEP THE GATE IN ITS FULLY OPEN POSITION AS LONG AS THE SIGNAL IS PRESENT. USED TO KEEP THE GATE OPEN WHILE VEHICLE IS PASSING THROUGH.
- +	ALARM	FACTORY CONNECTED TO THE ALARM BEEPER
N.O. COM N.C.	AUX RELAY	FACTORY CONNECTION AND PROGRAMMING FOR INTERNAL HOLDING BRAKE.
+ -	24 VOLT SOLAR PANEL	FOR CONNECTION TO 24 VOLT SOLAR PANEL FOR BATTERY CHARGING
+	24 VOLT BATTERY	FACTORY CONNECTED TO BATTERY CIRCUIT

# Basic Controller Programming

## Programming Overview

The controller can be programmed with various options for the operator. The programming fields are defined as “functions” that have “options”. To make setup easier for the installer, the Controller’s programming is divided into two groups: basic and advanced. The basic programming group contains the functions commonly used in most slide gate installations. The advanced programming group contains functions less commonly used (i.e. dual gate stagger delay, maximum run timer, etc.).

## Entering Programming Mode

Enter programming mode by pressing the **UP** and **DOWN** buttons together for one second. While in programming mode, the **PROGRAM** indicator will light.

## Exiting Programming Mode

Exit programming mode at any time by pressing the **UP** or **DOWN** buttons together. The Controller will automatically exit programming mode after three minutes of inactivity.

## Programming Keystrokes

While in programming mode, press **UP** or **DOWN** buttons to scroll through the programming functions. When the desired function is displayed press the **ENTER** button to display the currently set option for the function. **When an option is displayed, the decimal points are lit.**

To change the option press and hold the **ENTER** button for 1 second. To indicate that an option is ready to be changed, the display will flash. While the display is flashing, press the **UP** or **DOWN** button to display the other options available for that function.

When the desired option is displayed, press the **ENTER** button to store it into memory. To select another function, press **ENTER, UP,** or **DOWN.**

## Enter Left or Right Hand Operation

The factory default is right hand (Operator on the right when viewed from inside the gate). For left hand installations, program the controller for left hand operation.

## Dual Gate Enable

The factory default is for single gate operation. For dual gate operation, wire the two gate controllers together through the **COMM LINK** terminals (see page 23) and enable dual gate operation with this programming step.

## Auto Close Timer

The factory default the Auto Close timer for 5 seconds. The timer can be set from 1 to 59 seconds and from 1 to 9 minutes. When the Auto Close timer is set, after opening, the gate will wait for the length of the Auto Close Timer then close automatically

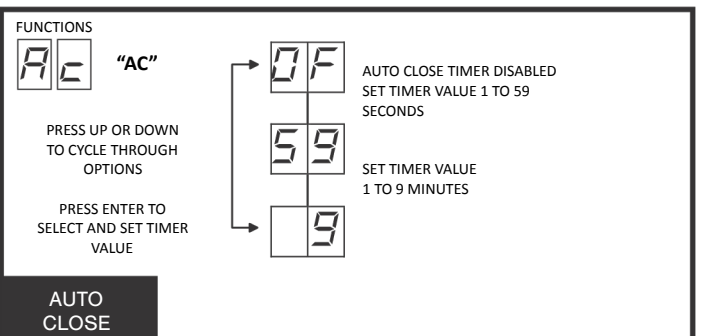
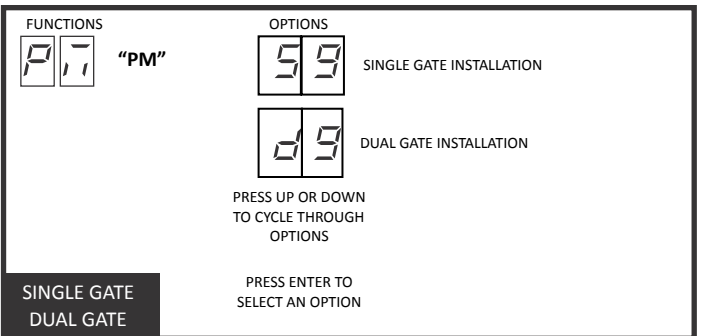
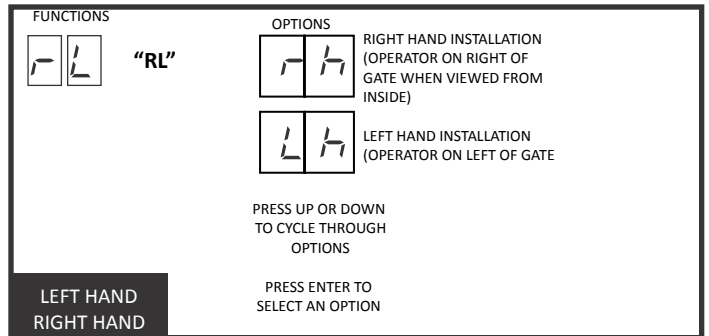
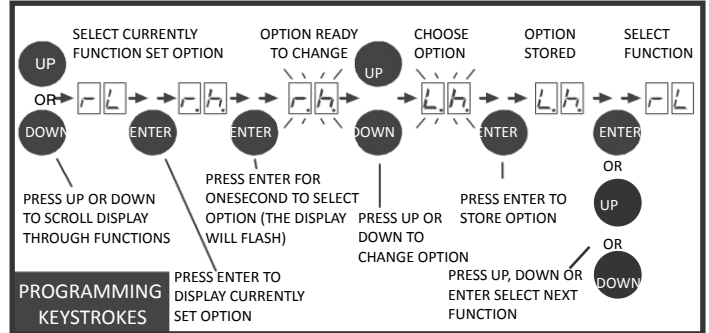
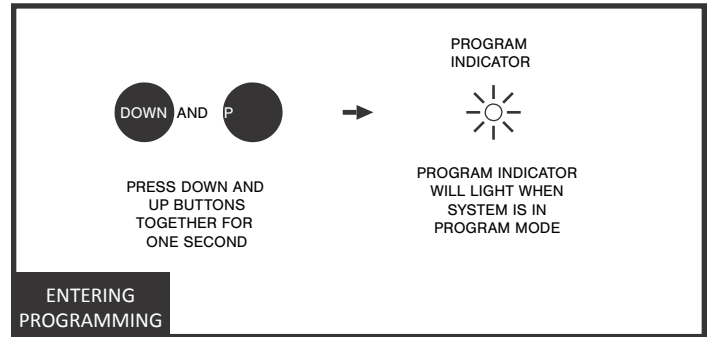

## Basic Controller Programming (Cont.)

### Run Alarm and Pre-start Alarm

The factory default is Run alarm on and a 3-second Pre-start Alarm. The operator's beeper will sound 3 seconds before the operator starts. The options are:

- **Run Alarm Off and Pre-start Alarm Off**
- **Run Alarm On and Pre-start Alarm Off 15**
- **Run Alarm On and Pre-start Alarm On for 3-9 seconds**

### Maximum Open Direction Current Setting

To detect obstacles or mechanical problems with the gate, the operator monitors its motor current. If the open current load exceeds the programmed maximum load range number, the operator will stop, reverse a short distance, then stop again. The Auto Close Timer will be disabled, and another open request will be required to start the operator again. If after restart, the overload or an open obstacle happens again before the open limit is reached, the operator will lockout and sound the alarm.

**Factory set to 0.5. Adjust according to gate size and weight to reverse when an obstruction is encountered but set high enough to avoid false triggers.**

**NOTE: THIS VALUE WILL BE SET TO "0.0" WHEN "SS" SETTING IS CHANGED AND MUST BE SET BACK TO DESIRED VALUE.**

### Maximum Close Direction Current Setting

To detect obstacles or mechanical problems with the gate, the operator monitors its motor current. If the close current load exceeds the programmed maximum load range number, the operator will stop, reverse, and travel to the full open position. Should an open obstruction input or an open direction inherent entrapment condition occur prior to the gate reaching the open limit, the operator will lockout and sound the continuous tone alarm. Another close request will be required to start the operator again. If after restart, the overload or a close obstacle happens again before the close limit is reached, the operator will lockout and sound the alarm. If the auto close timer is set, when the close obstruction input is cleared, the gate will close when the auto close timer expires.

**Factory set to 0.5. Adjust according to gate size and weight to reverse when an obstruction is encountered but set high enough to avoid false triggers.**

**NOTE: THIS VALUE WILL BE SET TO "0.0" WHEN "SS" SETTING IS CHANGED AND MUST BE SET BACK TO DESIRED VALUE.**

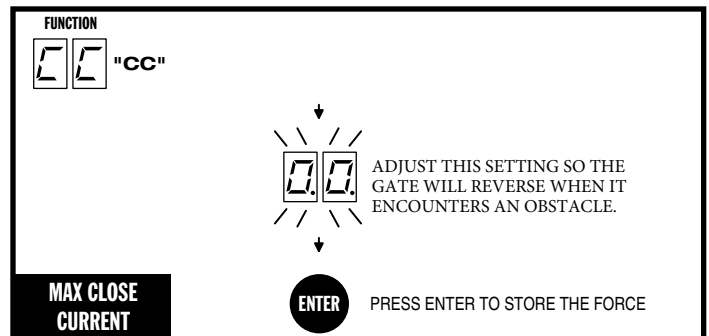
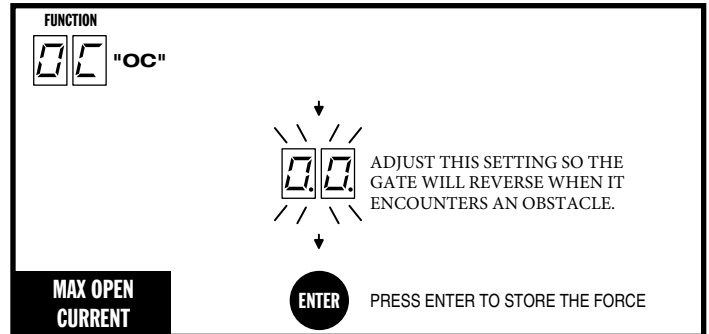
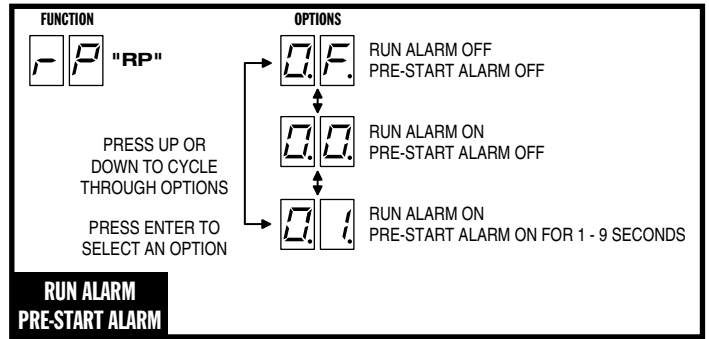

### Obstruction detection type – b1, b2

B1 is a non-contact sensor such as a photo eye. B2 is a contact sensor such as an edge. This setting affects behavior in the closed direction obstruction detection. If a B2 detector is used, the operator will only allow an input 2 times to continue automatic closing until a closed limit switch is successfully made. The first input while closing will reverse the operator to full open and resume auto close timer behavior if selected. The second input will cause the operator to reverse slightly and lockout.

✓ **NOTE:** Jumper wire must be cut and DIP switches set to position 5 for the functions below to be active.

### Open Obstruction input active – On, Off

If a swing gate has no entrapment areas this may be selected as off. This must be on for slide gates.

### Close obstruction input active – On, Off

Single gates require this to be on. Paired gates can have this off if the other gate has it turned on.

✓ **NOTE:** The following parameters will only be displayed if Paired Mode is selected ON. The operators must be both set as paired mode, powered up, and have the communication cable in place to complete this correctly. Obstruction inputs active selection for both operators must all be made from one side. Settings will be automatically transferred to the operator you are not in front of. Do not try to set individually

### Remote open obstruction active – On, Off

This is used to select if the other operator has the Open Obstruction input active.

### Remote Close obstruction active – On, Off

In paired mode it is only required to have 1 close device per pair of operators if the only entrapment zone is where the gates meet.

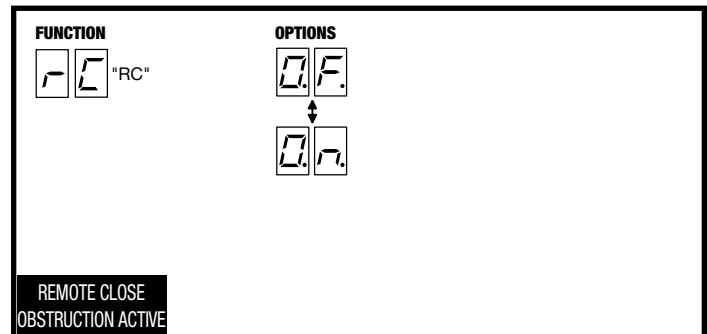
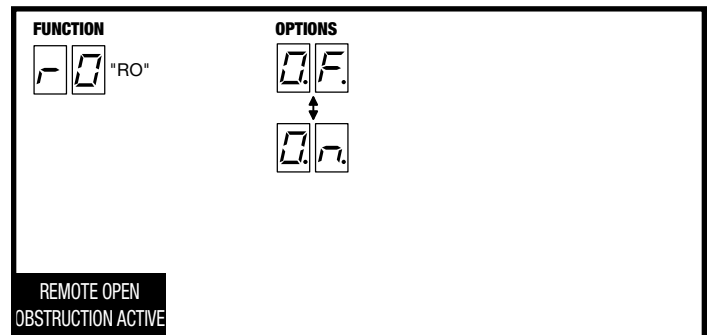
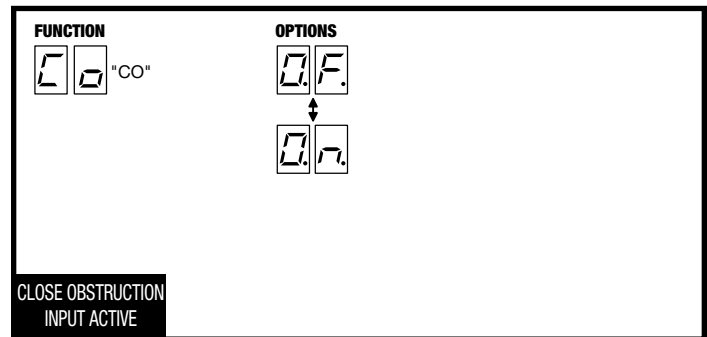
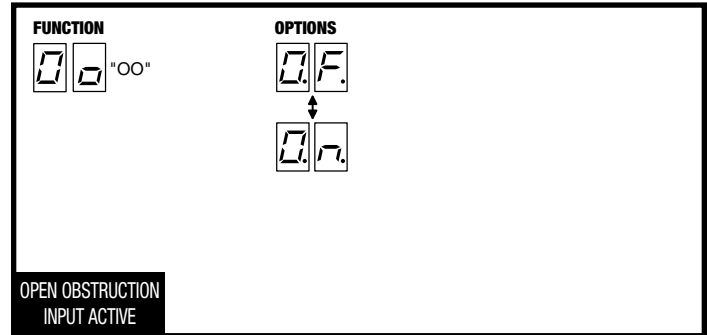
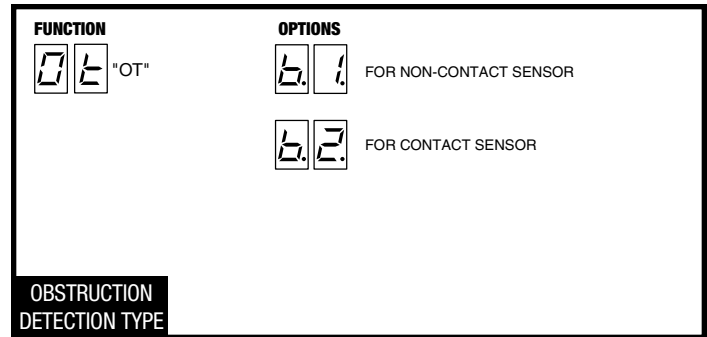

## Advanced Controller Programming

### Entering Advanced Programming Mode

To access and program the advanced Programming functions, for each programming session. Advanced Programming must be enabled.

**After exiting programming, the Advanced Programming functions will be available on the programming display during the next programming session unless the operator has run 50 or more cycles. After that, Advanced Programming must be enabled again.**

### Maximum Run Time

The factory default for the maximum Run Time is 99 seconds. Each time the operator starts, the timer will start counting down. If an open or close limit is not reached or an obstacle or reversing input is not received before the timer expires, the operator will stop, the unit locks out and the alarm sounds. The timer can be set for 10 to 99 seconds.

### Single Button Input Setup

This function is used to set up the operator for single button controls and radio receivers. The factory default sets the **SINGLE** input terminal so successive inputs will cycle the operator in OPEN-STOPCLOSE-STOP order.

Alternatively, the **SINGLE** input can be set to cause the gate to OPEN unless the gate is fully open. If the gate is fully open, the input will cause the gate to CLOSE.

### Stagger Mode

**This function is used in dual gate installations only.** The factory default sets the Stagger Mode to OFF. In dual gate installations the two operators communicate through the 3-wire **COMM LINK** interface. When using the Stagger Mode, set one operator for delayed opening and the other operator for delayed closing. The Stagger Delay Time programming function (see below) sets the length of the delay.

**NOTE:** This function will only be displayed if dual gate operation is selected.

**This function is used in dual gate installations only.** The factory default sets the Stagger Time to 0 seconds (OFF). The Stagger Time sets the delay for the Stagger Mode. The Stagger time can be set from 1-99 seconds.

**NOTE:** This function will only be displayed if dual gate operation is selected.

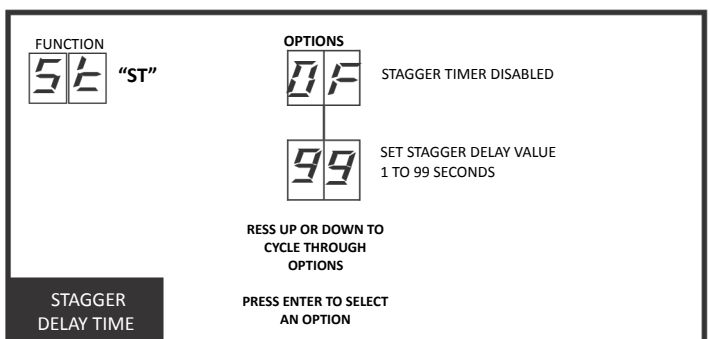
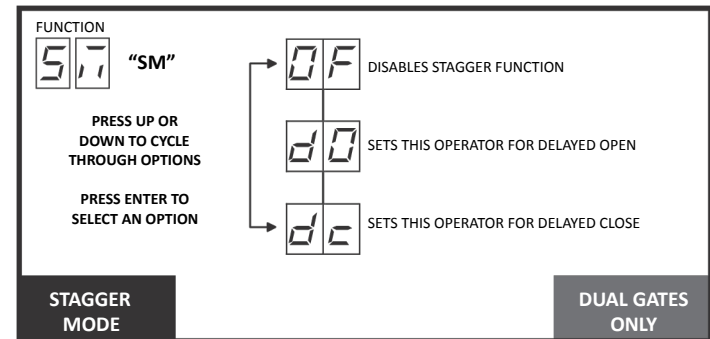
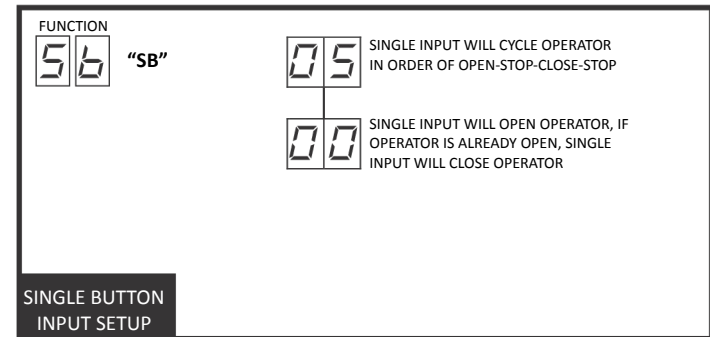
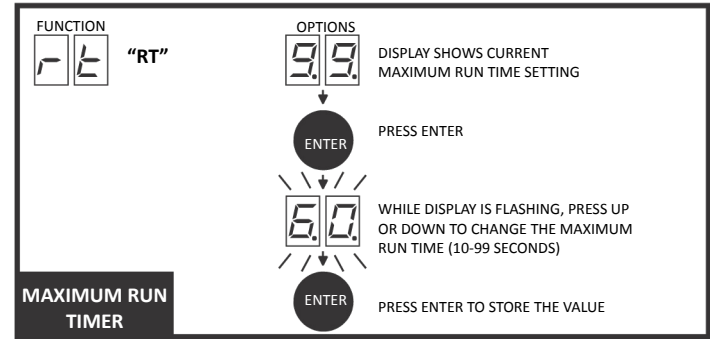
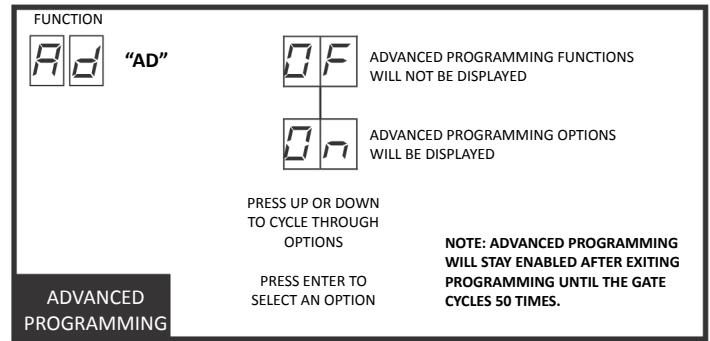

## Advanced Controller Programming (Cont.)

### Auxiliary Relay Mode - **MUST BE SET TO STROBE**

The Auxiliary Relay in the SW-C is used to release the internal brake in the operator. The AUXILLIARY RELAY MODE is factory set to STROBE. If this programming function gets changed from the factory setting, it must be restored prior to running the operator.

**Strobe:** the relay will energize during any pending or actual gate motion (either open or close), to activate a warning strobe light.

**NOTE: THIS FUNCTION MUST BE SET TO "STROBE" OR DAMAGE TO OPERATOR MAY OCCUR.**

### Reverse Delay Time

The factory default sets the Reverse Delay to 1 second. The operator will wait the length of the delay before reversing direction. This feature will not change the reversal time when the operator is responding to an entrapment condition from an obstruction input or inherent entrapment protection sensor. The Reverse Delay can be set from 1 to 9 seconds. Heavier gates require a longer delay to allow time for the gate to stop.

### Low Power Mode

The factory default disables the Low Power Mode. When Low Power Mode is enabled, and AC power fails, the controller will assume Low Power Mode after 10 seconds of gate inactivity. Low Power Mode turns off all accessory power and indicators. Only inputs from the radio receiver, reverse loop or opening device will activate gate.

### Power Failure Mode

The factory default is set for **Open Immediate**; alternately the controller can be set for Fail Secure, Open Immediate, or Close Immediate.

- **Fail Safe:** If the AC power fails and the battery voltage drops below 17 volts, 5 seconds later the operator will cycle open if not already open and cease operation. When AC power is restored, the operator will resume normal operation and auto-close if programmed to do so.
- **Fail Secure:** If the AC power fails and the battery voltage drops below 17 volts, 5 seconds later the operator will cycle closed if not already closed. When AC power is restored, or the battery gets charged by solar panels, the operator will resume normal operation.
- **Open Immediate:** If the AC power fails, the operator will cycle open if not already open and cease operation. When AC power is restored, the operator will resume normal operation and auto-close if programmed to do so.
- **Close Immediate:** If the AC power fails, the operator will cycle closed if not already closed and cease operation. When AC power is restored, the operator will resume normal operation.

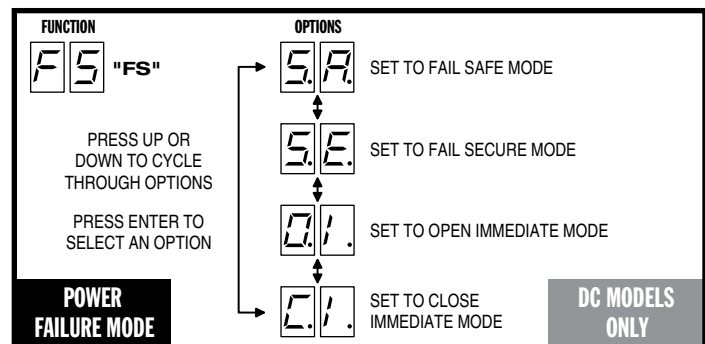
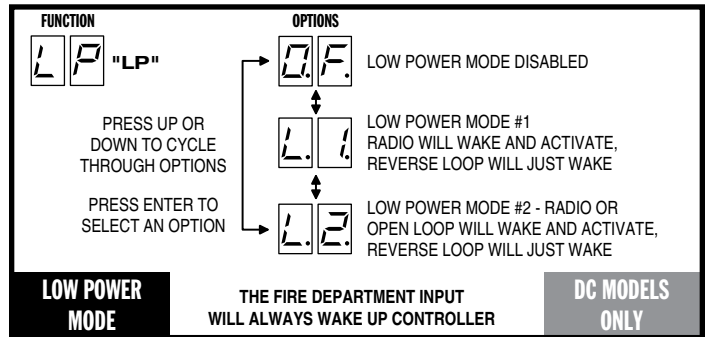
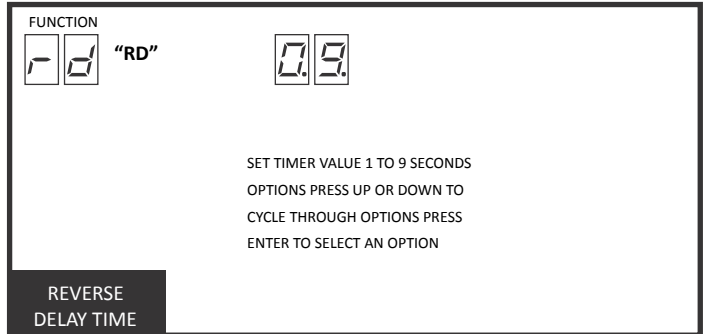
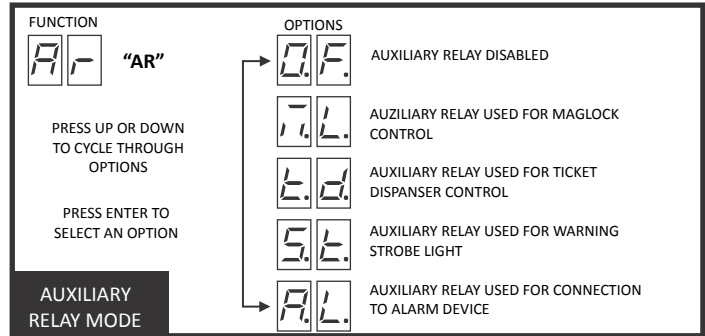

## Advanced Controller Programming (Cont .)

### Soft Start/Stop Duration

This function causes the operator to start and stop slowly, reducing wear and tear (at the full open or closed positions only). The factory default sets the Soft Start/Stop Duration to 3 seconds. **NOTE: AFTER ADJUSTING THIS SETTING, THE OPEN (OC) AND CLOSE (CC) CURRENT SENSING SETTINGS WILL HAVE TO BE READJUSTED.**

### Reset Cycle Count

The controller counts the number of times the operator has been activated and can display the count rounded off to the nearest 1000. To reset the cycle count, press and hold the **ENTER** button for 2 seconds while the Cycle Count is displayed. If the Maintenance Alert has been triggered, resetting the cycle count will also reset the Maintenance Alert indicator.

### Maintenance Alert Trigger

The controller has a **MAINT ALERT** indicator that can be programmed to light when the number of activations exceeds a set number of cycles. The factory default sets the Maintenance Alert Trigger to 10,000 cycles. The Maintenance alert Trigger can be programmed for 5, 10, 15, 25 thousand cycles. The Maintenance Cycle Count can be reset independently from the operator's absolute Cycle Count.

### Mid-Travel Stop Position

The controller can be programmed so that the gate will stop at mid-travel point instead of fully opening. This can be useful in installations where a large gate, that takes a long time to open and close fully, only needs to be opened partway to allow traffic to pass. The factory default sets the controller for full open operation. Alternately, the controller can be programmed to open for 1 to 99 seconds then stop, before reaching the open limit. When a Mid-travel stop position time has been programmed, the gate will **still fully open** if the Fire Department input is triggered, if the **OPEN** button is held down beyond the Mid-travel stop position, or a reverse obstacle or loop input is triggered.

**NOTE:** The Mid-travel stop feature is disabled when dual gate operation is enabled for paired units.

### Motor Type Selection

The motor type selection is set at the factory. If it becomes necessary to reset the motor type, it should be set to:

**THE MOTOR TYPE SHOULD BE: "d2"**

FUNCTION	OPTIONS
55 "SS"	0F SOFT START DISABLED
	10 SET SOFT START DURATION TIME

PRESS UP OR DOWN TO CYCLE THROUGH OPTIONS

PRESS ENTER TO SELECT AN OPTION

**SOFT START/STOP**

FUNCTION	OPTIONS
0E "CT"	99 DISPLAY SHOWS NUMBER OF OPERATION CYCLES (OPEN OR CLOSE) ROUNDED TO THE NEAREST 1000

**NOTE: PRESS ENTER FOR 2 SECONDS WHILE THE "CT" FUNCTION IS DISPLAYED TO RESET CYCLE TIMER TO ZERO**

**RESET CYCLE COUNT**

FUNCTION	OPTIONS
0A "MA"	0F DISABLES THE MAINTENANCE ALERT FUNCTION
	25 SETS THIS MAINTENANCE ALERT TRIGGER FOR 5, 10, 15, OR 25 THOUSAND CYCLES
	0E RESETS THE MAINTENANCE ALERT INDICATOR AND SETS THE MAINTENANCE ALERT COUNT TO ZERO

**MAINTENANCE ALERT TRIGGER**

FUNCTION	OPTIONS
0E "MT"	0F MID-TRAVEL STOP DISABLED (GATE RUNS FULL TRAVEL)
	99 SET LENGTH OF OPENING TIME FROM 1 TO 99 SECONDS

PRESS UP OR DOWN TO CYCLE THROUGH OPTIONS

PRESS ENTER TO SELECT AN OPTION

**MID-TRAVEL STOP POSITION**

FUNCTION	OPTIONS
00 "MO"	A0 AC MOTOR ONLY
	d1 DC MOTOR ONLY WITH BRAKING
	d2 DC MOTOR WITH SOFT START/STOP
	30 3 PHASE AC MOTOR
	b1 AC MOTOR PRIMARY WITH DC MOTOR BACKUP WITH BRAKING
	b2 AC MOTOR PRIMARY WITH DC MOTOR BACKUP WITH SOFT START/STOP

PRESS UP OR DOWN TO CYCLE THROUGH OPTIONS

PRESS ENTER TO SELECT AN OPTION

**NOTE: SELECTION MUST MATCH MOTOR BOARD!**

**MOTOR TYPE SELECTION**

## Advance Controller Programming (Cont.)

### Radio Enable

The controller contains a built in MegaCode® radio receiver to allow activation from up to 40 access control transmitters and two Model MGT (gate edge) transmitters. The factory default enables the internal radio receiver. Alternately, the internal receiver can be disabled.

**NOTE:** In dual-unit installations, it is recommended to disable the radio receiver in one of the two operators.

### Antenna Installation

The controller is supplied with a local whip antenna installed. If using a remote antenna, remove the whip antenna and connect coax cable from the antenna to the **ANTENNA** connector.

### Radio Transmitter Learn

The controller's built-in MegaCode® radio receiver can store the IDs of up to 40 transmitters. Refer to the figure for the steps required to learn transmitters.

**NOTE:** This function will NOT be displayed if the transmitter memory is full, or if the radio receiver is disabled.

### Radio Transmitter Delete

Transmitters can be deleted from the controller's memory either individually, or all at the same time. Refer to the figure for the steps required to delete transmitters.

**NOTE:** This function will NOT be displayed if the transmitter memory is full, or if the radio receiver is disabled.

### MGT Obstacle Transmitter Learn

The controller supports one or two Model MGT Obstacle Transmitters. The transmitters can be programmed to function as Open Obstruction, Close Obstruction, Reverse, or Stop. Refer to the figure for the steps required to learn MGT **NOTE:** This function will NOT be displayed if two MGT transmitters are already stored in memory, or if the radio receiver is disabled.

### MGT Obstacle Transmitter Delete

MGT transmitters can be deleted from the controller's memory either individually, or all at the same time. Refer to the figure for the steps required to delete MGT transmitters.

**NOTE:** This function will NOT be displayed if two MGT transmitters are already stored in memory, or if the radio receiver is disabled.

### Reset Controller to Factory Defaults

**DO NOT USE THIS FEATURE UNLESS INSTRUCTED TO DO SO BY ROTARY GATE SYSTEMS TECH SUPPORT.**

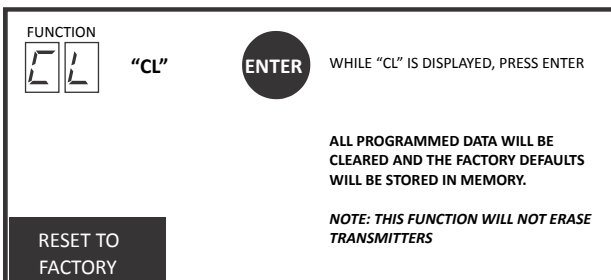
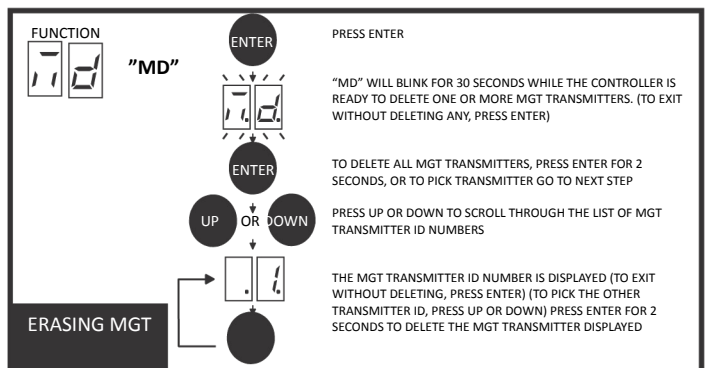
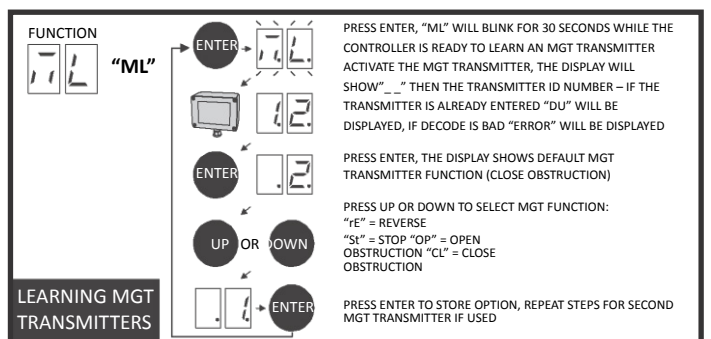
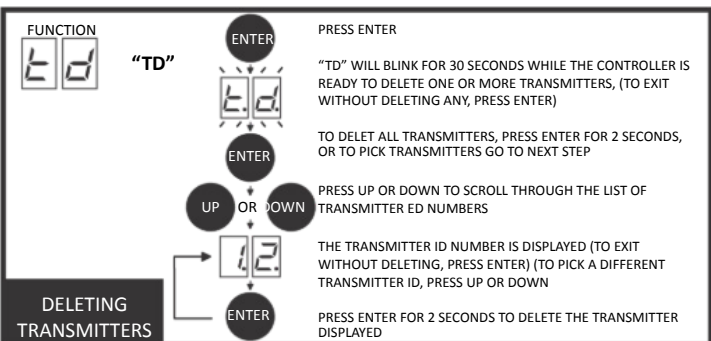
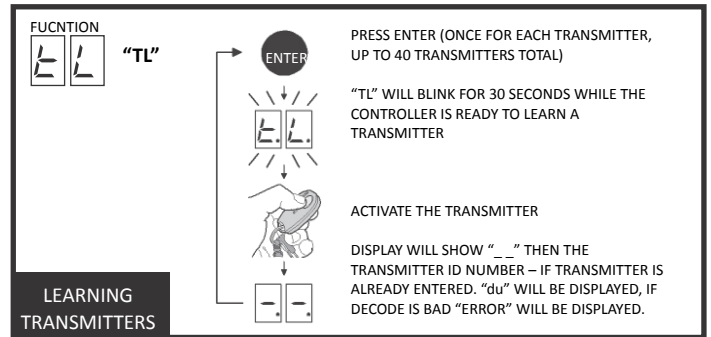
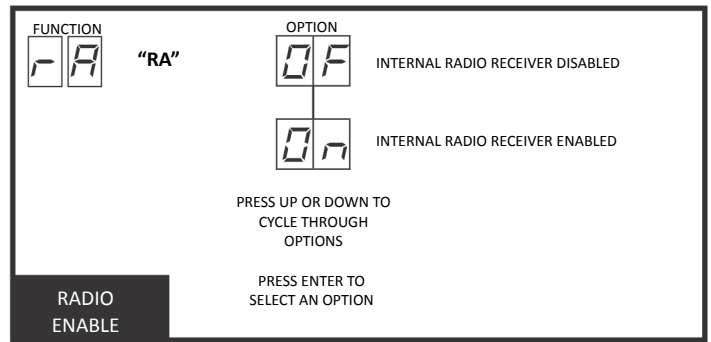

## Dual Gate Installations

Two operators can be used in dual gate installations. The operators communicate with each other through the 3-wire **COMM LINK** terminals.

When one operator activates, the **COMM LINK** connection signals the other operator to activate. Each operator functions independently, controlling its gate and monitoring its inputs and accessories.

A three-wire shielded conductor cable is required to connect two operators together for dual operation. Use belden 8760 Twisted Pair Shielded (or equivalent) only.

There are three programming functions pertaining exclusively to dual gate installations. Dual Gate Enable must be set. The Stagger Mode function determines if the operator has a delayed open or a delayed close. The Stagger Time sets the length of the delay for the Stagger Mode. In dual slide gate installations, typically one operator is programmed for delayed start and the other operator is programmed for delayed close. See Pages 11 & 13 for details on these programming functions.

**NOTE:** The shield wire should be connected COMM LINK terminal "C" in both operators.

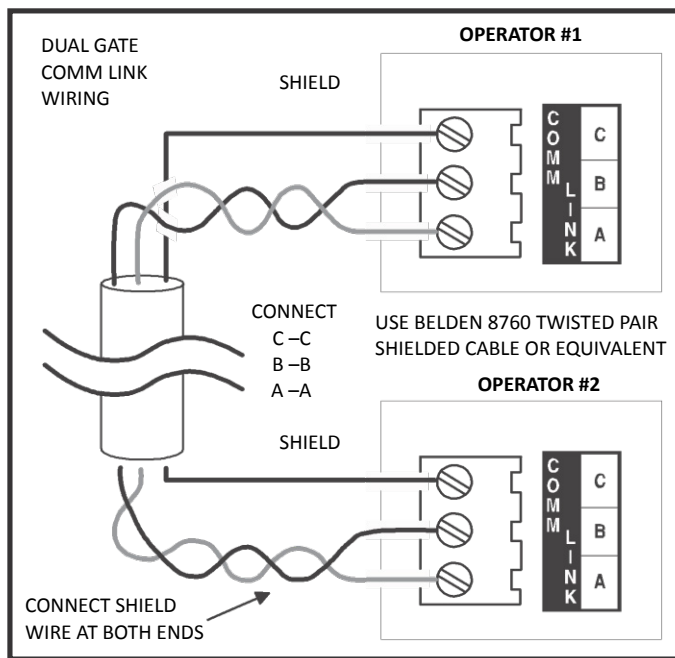

Figure 7. COMM LINK Wiring

## Gate Operation

### Open Button

Opens the gate. If the controller is programmed to stop opening the gate at mid-travel, a constant press of the **OPEN** button will override the Mid-travel Stop and completely open the gate. If the Auto Close Timer is set, it will be suspended until the **OPEN** button is released.

### Close Button

Closes the gate if the gate is open. Also closes the gate if the gate is in the process of opening.

### Stop Button

Stops the gate from opening or closing at any time.

### Single Input

Opens the gate if it's closed and closes the gate if it's open (open-close programming option). Activating the input while the gate is moving will reverse the gate. Can be programmed to stop the gate while the gate is moving (open-stop-close programming option).

### Fire Department Input

Fully opens the gate when the input is activated. Overrides the Mid-travel Stop and Auto Close Timer (if either is programmed for the gate). The gate will lockout in the open position without sounding the alarm. Press the **STOP** button to release the lockout.

### Open Input

Functions the same as the **OPEN** button.

### Open Obstruction

While the gate is opening, any open obstruction signal will cause the gate to stop, reverse a short distance, and then stop again. The auto close timer will be disabled, and a renewed input will be required to start the gate again. Should the gate be restarted and the obstacle signal occurs again prior to reaching a limit, the gate will stop again, lockout, and sound the emergency alarm.

### Close Obstruction

Same as the open obstruction, but in the closing direction.

### Reverse Input

If the reverse input is triggered while the gate is closing, the gate will reverse to the full open position. If the Auto close Timer is set, when the reverse input is cleared, the gate will close when the Auto Close Timer expires.

### Open Loop

Functions the same as the **OPEN** button.

### Reverse Loop

Functions the same as the reverse input.

### Shadow/reset Loop

Only used with Swing Gates. Holds the gate open while triggered. The gate closes immediately when cleared.

## Operation Indications

During normal operation, the controller's display will indicate current operating conditions and status.

### Power-up Display

When the controller powers up, dashes will show on the display for one second, then the firmware version number will be displayed for one second.

Exiting programming restarts the controller. The power-up display will show upon the restart.

### Idle Condition

While the controller is idling, waiting for a command, the display will show circulation dashes.

### Last Gate Position/Condition

When the gate moves or stops, the display will show the status for up to one minute.

- Stop is displayed as **St**
- Full Close is displayed as **FC**
- Full Open is displayed as **FO**
- Entrapment is displayed as **Et**

### Pre-Start Delay

During the pre-start delay, the display will countdown the number of seconds remaining before the operator starts

### Reverse Delay

If the gate travel direction is reversed from user activation or reversing device and a reverse delay is set, the display will count down the delay time in seconds before the operator restarts.

### Run Timer

While the gate is opening or closing, the number of seconds running time is displayed.

## Error Indications

During abnormal operation, the controller's displays and beeper will indicate the error condition that has occurred.

### Entrapment

If an entrapment condition occurs detected by two repeated open or close obstruction triggers, the controller will lock the operator out. The beeper will sound constantly and the gate will not operate. To reset the controller press the **STOP** button.



### WARNING



The Stop and/or Reset button must be located in the line-of-sight of the gate. Activation of the reset control shall not cause the operator to start.

### COMM LINK Connection Failure

In dual installations, if there is a connection failure between the two operators, the **COMM LINK** indicator will blink once a second. During this condition the gate will not operate, except if triggered by the **FIRE DEPT** input, which functions normally.

### MGT Obstacle Transmitter Trouble

If any MGT transmitters are used with the operator, their supervision feature will alert the controller if there is any trouble with the transmitter. MGT transmitters send hourly status reports and will send low battery reports when the transmitter

has a low battery. The MGT transmitters also have a tamper detection switch that will trigger when their case is opened. When the controller detects a low transmitter battery, a tamper signal, or missing transmitter status reports, the gate will still operate normally, but the beeper will change as follows:

- The Pre-start Alarm will beep twice as fast.
- The run alarm will beep twice as fast and continue for five minutes after the gate stops.
- The sounder will "chirp" every five seconds when the gate is idle.

Correct the trouble (close case, replace battery, or replace transmitter) to clear the obstacle transmitter trouble indications.

### Maximum run Time Exceeded

If the Maximum Run Time is exceeded, the controller stops the operator the same as if a double obstacle has occurred in an entrapment condition. The entrapment alarm sounds constantly, and is cleared by pressing the **STOP** button. After the **STOP** or **RESET** button is pressed, because the Maximum Run Time has been exceeded, the sounder will beep twice every five seconds. The next operation of the gate will clear the indication.

CONTROLLER ERROR CAUSES AND INDICATIONS		
ERROR CAUSE	ERROR INDICATION	HOW TO CLEAR
SAFETY REVERSALS (ON SINGLE GATE OR ON EITHER DUAL GATE)	00, CONTINUOUS ALARM BEEPER, GATE DISABLED	PRESS STOP BUTTON
MAXIMUM RUN TIMER EXCEEDED ON OPENING	En 01, AND <b>MAX RUN</b> LED, CONTINUOUS ALARM BEEPER, GATE DISABLED	PRESS STOP BUTTON CLEARS CONTINUOUS ALARM, THEN DOUBLE BEEP EVERY 5 SECONDS UNTIL NEXT OPERATION
MAXIMUM RUN TIMER EXCEEDED ON CLOSING	En 02, AND <b>MAX RUN</b> LED, CONTINUOUS ALARM BEEPER, GATE DISABLED	PRESS STOP BUTTON CLEARS CONTINUOUS ALARM, THEN DOUBLE BEEP EVERY 5 SECONDS UNTIL NEXT OPERATION
COMM LINK FAILURE	En 03, AND <b>COMM LINK</b> LED, CONTINUOUS ALARM BEEPER FOR 1 MINUTE, GATE DISABLED (EXCEPT FOR FIRE DEPT INPUT)	PRESS STOP BUTTON, CLEARS CONTINUOUS ALARM
GATE FULL OPEN RESULTING FROM FIRE DEPT INPUT	En 04, GATE DISABLED	PRESS STOP OR RESET BUTTON, GIVE OPEN OR CLOSE COMMAND
FAIL SAFE OR FAIL SECURE BECAUSE OF AC POWER LOSS	En 05, GATE DISABLED	BATTERY VOLTAGE MUST RISE ABOVE 24 VDC
OTHER CONTROLLER IN ENTRAPMENT (DUAL GATE)	En 06, GATE DISABLED	CLEAR ENTRAPMENT ON OTHER CONTROLLER (PRESS STOP)
LOW AC VOLTAGE AT CONTROLLER	En 07, GATE DISABLED	LOW VOLTAGE AC POWER MUST RISE ABOVE 20 VAC
INPUT TRIGGERED DURING ENTRAPMENT LOCKOUT	En 08, GATE DISABLED	PRESS STOP BUTTON
COMPATIBILITY PROBLEM	En 09, GATE DISABLED	UPDATE FIRMWARE AND RESET BOTH PAIRED CONTROLLERS
EEPROM PROBLEM	En 10, GATE DISABLED	TRY RESET, CALL TECH SUPPORT
DC MOTOR MISMATCH	En 11, GATE DISABLED	REPROGRAM MOTOR TYPE OR CHANGE DC MOTOR BOARD, NEXT GATE MOVEMENT WILL RETRY DC MOTOR CHECK
MOTOR FAILURE	En 12, GATE DISABLED	CHECK MOTOR CONNECTIONS
MGT SUPERVISORY CONDITION (TAMPER, LOW BATTERY, MISSING HOURLY STATUS)	FAST BEEPS DURING RESTART FAST BEEP RUN ALARM, CHIRP EVERY 5 SECONDS AT IDLE	CLEARS WHEN MGT CONDITION CLEARS

## Troubleshooting

### Contacting Technical Support

For technical questions regarding ROTARY GATE SYSTEMS gate operators, please contact the Technical Support Department at 1-877-331-4747.

#### *Operator fails to start*

- A. Make sure you have power at the master distribution panel and that the power has not been turned off.

#### *Motor operates, but gate does not move*

##### *Motor sounds like it is working harder than normal*

- A. Check Battery Voltage (should be 24-28 volts).
- B. Remove Upper Cap from operator and check Clutch friction. Loosen 9/16 nut and check operator movement. Slowly tighten nut until gate movement is firm but operator is not straining.

##### *Gate stopping part way open or closed (but no visible obstruction)*

- A. The controller may have received a false obstruction input triggered by current sensing set too low. Make sure the gate moves freely through its entire travel before adjusting the current sensing.
- B. The Maximum Run Timer may have counted down and expired. This can be caused by having the timer set too low. When the timer expires, the gate stops and the beeper will sound.
- C. An obstruction signal from an accessory wired to the obstruction input may have triggered falsely. Check the control board for lit indicators for any of the following inputs: safety, shadow/reset, open obstruction, close obstruction, stop, etc. If any are lit when the operator should be running, remove all devices hooked to that function and hook them up one at a time and try to run the operator until the problem device is found

#### *Gate staying open with automatic system*

- A. If there are vehicle detectors used with the operator, one of the loops or loop detectors may be sending a false signal or needs to be reset. Observe the indicators on the loop detector. Unplug the detector and try running the operator.
- B. An opening or reversing device may be stuck or malfunctioning. Try disconnecting these devices and hook them back up one at a time and try running the operator until the malfunctioning device is found.
- C. Make sure the close limit switch isn't activated. If it is, the operator will think the gate is already closed.
- D. Any input into the Fire Dept terminal on the APeX controller will open the gate and hold it open. This will be indicated by EN 04 on the APeX display. To clear this error, press the RESET button on the outside of the control box and give the system an OPEN or CLOSE signal.

## Model SW-C Maintenance

### *Battery Maintenance*

The gel-cell batteries in this operator require no routine maintenance. For assured continued performance, they should be replaced every year. If power is to be removed for one week or more, disconnect the negative wire from the batteries as this will prevent deep discharging. Fully charge before use, after storage or upon initial installation.

## Preventative maintenance

Always disconnect power from operator before servicing. Keep clear of gate during operation.

### *General*

RGS gate operators are designed for many years of trouble-free operation, and, under recommended operating conditions, will require only minimal maintenance. To ensure that a unit is ready for operation at all times, and to preclude serious damage or failure, inspect the unit systematically. Proper adjustments should be made as recommended.

For all gate operators, you must inspect the gate for proper operation. Failure to keep the gate in good working condition will have adverse effects on the operator.

### *Six-Month Preventative Maintenance*

1. Inspect all nuts and bolts for proper tightness and tighten as necessary.
2. Check all reversing devices for proper function. Inspect all contact edges for wear and replace if required. Check photoeyes for proper alignment and function.
3. Check current sensing for proper adjustment when finished with inspections and maintenance.
4. Inspect the installation area. Are all the warning signs intact and visible? If they are missing or need replaced contact RGS. Be sure no control stations are mounted within reach of the gate. Review safety literature with the customer and advise them to remove any such stations found.

### FCC Notice

This device complies with FCC Rules Part 15 and Industry Canada Rules & Regulations. Operation is subject to the following two conditions: (1) this device may not cause harmful interference and (2) the device must accept any interference received, including interference that may cause undesired operation.

# **WARRANTY**

---

## **ROTARY GATE SYSTEMS, INC. 5 YEAR LIMITED WARRANTY**

Rotary Gate Systems, Inc. warrants to the original installing dealer of the SW-C gate operator that it will be free from defects in materials and workmanship for a period of five (5) years from the date of original purchase from Rotary Gate Systems. This warranty applies only to the SW-C gate operator and not to the APeX controller. A two (2) year warranty applies to the APeX controller, power transformer and power box. Rotary Gate Systems, Inc. warrants to the original installing dealer of the unit that it will be free from defects in materials and workmanship for a period of two (2) years from the date of original purchase from Rotary Gate System, Inc.

If the SW-C requires service, contact the dealer who originally installed it. If that dealer is not available, call 1-877-331-4747 to be referred to a dealer in your area.

THIS WARRANTY APPLIES ONLY TO THIS PRODUCT WHEN INSTALLED BY A QUALIFIED DEALER AND NOT TO ANY ACCESSORIES, THE GATE PANEL ITSELF, OR ANY GATE SUPPORT HARDWARE. THIS WARRANTY ONLY COVERS THE GATE OPERATOR AND CONTROLLER. THE INSTALLING DEALER MAY PROVIDE DIFFERING WARRANTIES FOR HIS SERVICES.

ALL WARRANTIES (IMPLIED OR UNIMPLIED) ARE LIMITED TO A PERIOD OF FIVE (5) YEARS. SOME STATES DO NOT ALLOW LIMITATIONS ON HOW LONG AN IMPLIED WARRANTY MAY LAST, SO THIS LIMITATION MAY NOT APPLY TO YOU.

ROTARY GATE SYSTEMS, INC. shall not be held liable for any consequential, incidental or special damages in connection with the installation, use or inability to use this product. The limitations of liability for ROTARY GATE SYSTEMS, INC. shall be limited to repair or replacement of this product.

Some states do not allow exclusion or limitation of consequential, incidental or special damages, so the preceding exclusions may not apply to you. This warranty gives you specific legal rights and you may have other rights which may vary from state to state.

This warranty is not transferable.