

S450H

Hydraulic Swing Gate Operator

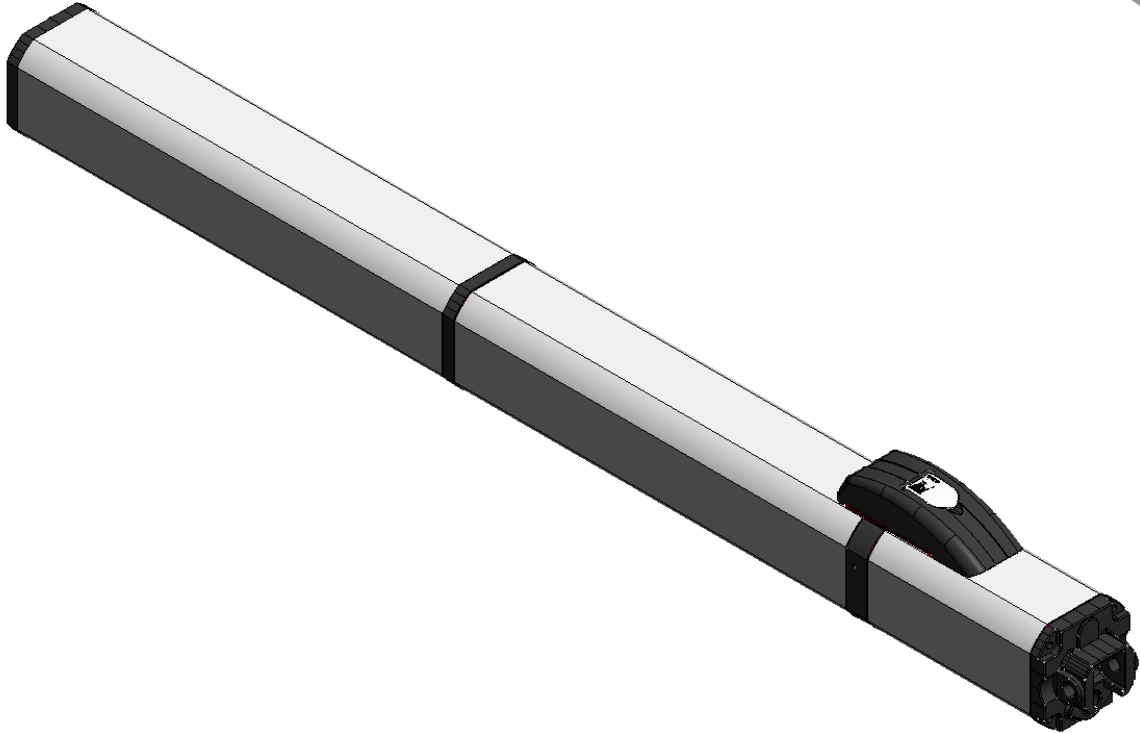

FAAC International Inc.
Headquarter & East Coast Operations
3160 Murrell Road
Rockledge, FL 32955
Tel. 800 221 8278

FAAC International Inc.
West Coast Operations
17595 Cartwright Rd
Irvine, CA 92614

FAAC

TABLE OF CONTENTS

Important Safety Information	3		
Important Installation Information	3		
General Safety Precautions	4		
UL325 Gate Operator Classifications	5		
Installing the Warning Signs	5		
S450H OPERATOR			
1. DESCRIPTION AND SPECIFICATIONS	6		
1.1 Dimensions	6		
1.2 Wiring	6		
2. INSTALLATION	6		
2.1 Preliminary Checks	6		
2.2 Installation Dimensions With Bracket Fastened To The Column	7		
2.3 Installation Dimensions With Bracket Fastened To The Side Wall	8		
2.4 Installation Steps	9		
3. MANUAL OPERATIONS	11		
4. ENCODER CONNECTION	11		
5. BLEEDING	13		
6. PERIODIC PRESSURE RELIEF	13		
		E024U CONTROL BOARD	
		1. Description and Characteristics	14
		2. Inputs / Outputs Description	15
		3. Safety Devices Connections	16
		4. Programming	18
		5. Led Diagnostics	21
		6. Time Learning (Set-Up)	23
		7. Obstacle Detection	24
		8. Enclosure	24
		9. Power Connection	25
		10. Backup Battery	26
		11. Firmware Upgrade	26
		12. Function Logics	27
		13. Accessories	30
		SPARE PARTS	
		Spare Parts Diagram	33

IMPORTANT SAFETY INFORMATION

WARNING - to reduce the risk of severe injury or death:

1. READ AND FOLLOW ALL INSTRUCTIONS.
2. Never let children operate or play with the gate controls. Keep remote controls away from children.
3. Always keep people and objects away from the gate. NO ONE SHOULD CROSS THE PATH OF A MOVING GATE.
4. Test the gate operator monthly. The gate MUST reverse on contact with a rigid object or stop when an object activates the non-contact sensors. After adjusting the force or the limit of travel, retest the gate operator. Failure to adjust and retest the gate operator properly can increase the risk of severe injury or death.
5. Use the manual release only when the gate is not moving.
6. KEEP GATES PROPERLY MAINTAINED. Read the user's manual. Have a qualified service person make repairs to gate hardware.
7. The entrance is for vehicles only. Pedestrians must use a separate entrance.
8. SAVE THESE INSTRUCTIONS.

IMPORTANT INSTALLATION INFORMATION

- a) Install the gate operator only when:
 - 1) The operator is appropriate for the construction of the gate and usage Class of the gate,
 - 2) All openings of a horizontal slide gate are guarded or screened from the bottom of the gate to a minimum of 1.83 m (6 ft) above the ground to prevent a 57.2 mm (2-1/4 in) diameter sphere from passing through openings anywhere in the gate, and in that portion of the adjacent fence that the gate covers in the open position,
 - 3) All areas of the moving vertical pivot gate panel from the bottom of the gate to the top of the gate or a minimum of 1.83 m (72 in) above grade, whichever is less, that pass by a fixed stationary object, and in the area of the adjacent fence that the gate covers during the travel of the gate, shall be designed, guarded or screened to prevent a 57.2 mm (2-1/4 in) diameter sphere from passing through such areas.
 - 4) All exposed pinch points are eliminated or guarded, and
 - 5) Guarding is supplied for exposed rollers.
 - 6) The operator instructions shall list the maximum number of open and close entrapment protection devices capable of being connected to the operator.
- b) The operator is intended for installation only on gates used for vehicles. Pedestrians must be supplied with a separate access opening. The pedestrian access opening shall be designed to promote pedestrian usage. Locate the gate such that persons will not come in contact with the vehicular gate during the entire path of travel of the vehicular gate.
- c) The gate must be installed in a location so that enough clearance is supplied between the gate and adjacent structures when opening and closing to reduce the risk of entrapment. Swinging gates shall not open into public access areas.
- d) The gate must be properly installed and work freely in both directions prior to the installation of the gate operator. Do not over-tighten the operator clutch or pressure relief valve to compensate for an improperly installed, improperly functioning, or damaged gate.
- e) For gate operators utilizing Type D protection:
 - 1) The gate operator controls must be placed so that the user has full view of the gate area when the gate is moving,
 - 2) An additional placard that is marked in letters at least 6.4-mm (1/4-in) high with the word "WARNING" and the following statement or the equivalent: "Moving Gate Has the Potential of Inflicting Injury or Death – Do Not Start Gate Unless Path is Clear." shall be placed adjacent to the controls,
 - 3) An automatic closing device (such as a timer, loop sensor, or similar device) shall not be employed, and
 - 4) No other activation device shall be connected.
- f) Permanently mounted controls intended for user activation must be located at least 1.83 m (6 ft) away from any moving part of the gate and where the user is prevented from reaching over, under, around or through the gate to operate the controls.

Exception: Emergency access controls only accessible by authorized personnel (e.g. fire, police, EMS) may be placed at any location in the line-of-sight of the gate.
- g) The Stop and/or Reset buttons must be located within line-of-sight of the gate. Activation of the reset control shall not cause the operator to start.
- h) A minimum of two (2) WARNING SIGNS shall be installed, in the area of the gate. Each placard is to be visible by persons located on the side of the gate on which the placard is installed.
- i) For gate operators that utilize a non-contact sensor (photo beam or similar):
 - 1) See instructions on the placement of non-contact sensors for each type of application,
 - 2) Care should be exercised to reduce the risk of nuisance tripping, such as when a vehicle trips the sensor while the gate is still moving, and
 - 3) One or more non-contact sensors shall be located where the risk of entrapment or obstruction exists, such as the perimeter reachable by a moving gate or barrier.

- j) For gate operators that utilize a contact sensor (edge sensor or similar):
- 1) One or more contact sensors shall be located where the risk of entrapment or obstruction exists, such as at the leading edge, trailing edge, and postmounted both inside and outside of a vehicular horizontal slide gate.
 - 2) One or more contact sensors shall be located at the bottom edge of a vehicular vertical lift gate.
 - 3) One or more contact sensors shall be located at the pinch point of a vehicular vertical pivot gate.
 - 4) A hardwired contact sensor shall be located and its wiring arranged so that the communication between the sensor and the gate operator is not subjected to mechanical damage.
 - 5) A wireless device such as one that transmits radio frequency (RF) signals to the gate operator for entrapment protection functions shall be located where the transmission of the signals are not obstructed or impeded by building structures, natural landscaping or similar obstruction. A wireless device shall function under the intended end-use conditions.
 - 6) One or more contact sensors shall be located on the inside and outside leading edge of a swing gate. Additionally, if the bottom edge of a swing gate is greater than 152 mm (6 in) but less than 406 mm (16 in) above the ground at any point in its arc of travel, one or more contact sensors shall be located on the bottom edge.
 - 7) One or more contact sensors shall be located at the bottom edge of a vertical barrier (arm).

GENERAL SAFETY PRECAUTIONS

Gate Construction

Vehicular gates should be constructed and installed in accordance with ASTM F2200: Standard Specification for Automated Vehicular Gate Construction.

For a copy of the standard, contact ASTM directly at 610-832-9585 or www.astm.org

Installation

- If you have any questions or concerns regarding the safety of the gate operating system, do not install the operator and consult the manufacturer.
- The condition of the gate structure itself directly affects the reliability and safety of the gate operator.
- Only qualified personnel should install this equipment. Failure to meet this requirement could cause severe injury and/or death.
- The installer must provide a main power switch that meets all applicable safety regulations.
- It is extremely unsafe to compensate for a damaged gate by increasing the operator's force.
- Install devices such as reversing edges and photo beams to provide better protection for personal property and pedestrians. Install reversing devices that are appropriate to the gate design and application.
- Before applying electrical power, ensure that voltage requirements of the equipment correspond to the supply voltage. Refer to the label on your gate operator system.

Usage

- Use this equipment only in the capacity for which it was designed. Any use other than that stated should be considered improper and therefore dangerous.
- The manufacturer cannot be held responsible for damage caused by improper, erroneous or unreasonable use.
- If a gate system component malfunctions, disconnect the main power before attempting to repair it.
- Do not impede the movement of the gate, you may injure yourself or damage the gate system as a result.
- This equipment may reach high thermal temperatures during normal operation, therefore use caution when touching the external housing of the gate operator.
- Use the manual release mechanism according to the procedures presented in this manual.
- Before performing any cleaning or maintenance operations, disconnect power to the equipment.
- All cleaning, maintenance or repair work must be performed by qualified personnel.

UL325 Gate Operator Classifications

CLASS I - RESIDENTIAL VEHICULAR GATE OPERATOR

A vehicular gate operator (or system) intended for use in garages or parking areas associated with a residence of one to four single families.

CLASS II - COMMERCIAL / GENERAL ACCESS VEHICULAR GATE OPERATOR

A vehicular gate operator (or system) intended for use in commercial locations or buildings such as multi-family housing units (five or more single family units), hotel, garages, retail store, or other buildings accessible by or servicing the general public.

CLASS III - INDUSTRIAL / LIMITED ACCESS VEHICULAR GATE OPERATOR

A vehicular gate operator (or system) intended for use in an industrial location or building such as a factory or loading dock area or other locations not accessible by or intended to service the general public.

CLASS IV - RESTRICTED ACCESS VEHICULAR GATE OPERATOR

A vehicular gate operator (or system) intended for use in guarded industrial locations or buildings such as an airport security area or other restricted access locations not servicing the general public, in which unauthorized access is prevented via supervision by security personnel.

Installing the Warning Signs

This FAAC swing gate operator is supplied with two warning signs to alert people that a possible hazard exists and that appropriate actions should be taken to avoid the hazard or to reduce exposure to it.

Permanently install one warning sign on each side of the gate so they are fully visible to traffic and pedestrians.

Use appropriate hardware such as metal screws (not supplied) to permanently install each warning sign.



S450H OPERATOR

1. DESCRIPTION AND TECHNICAL SPECIFICATIONS

The self contained FAAC S450H operator is an electro-hydraulic unit consisting of a low voltage electric motor, a pump, a valve assembly and a hydraulic cylinder, all housed in an anodized aluminum body.

The model with hydraulic locking does not require the installation of electric locks and guarantees that the leaf is mechanically locked when the motor is not running. The model without hydraulic locking needs one or more electric locks to guarantee that the leaf doesn't move when the motor is not running.

The S450H operator is designed and manufactured to automate vehicular swing leaf gates. Do not use for any other purpose

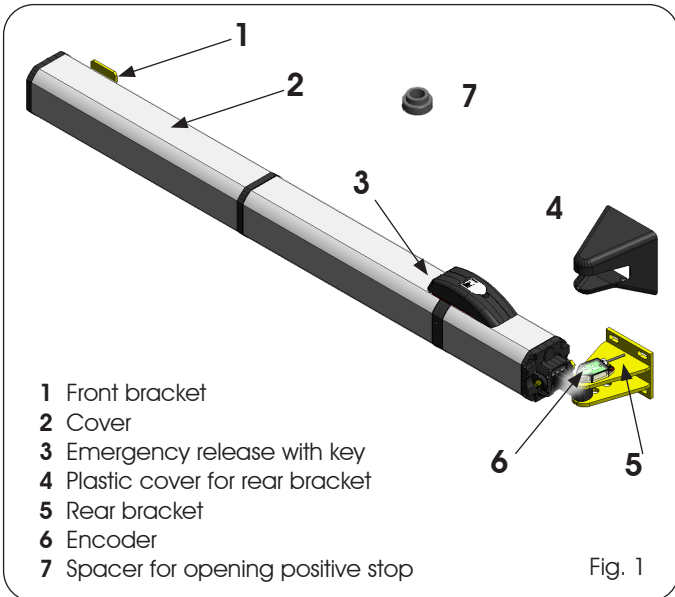

1.1 Dimensions

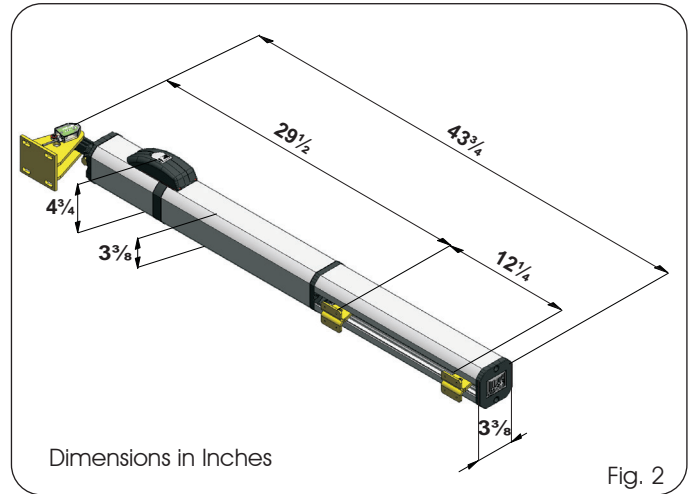

1.2 Wiring

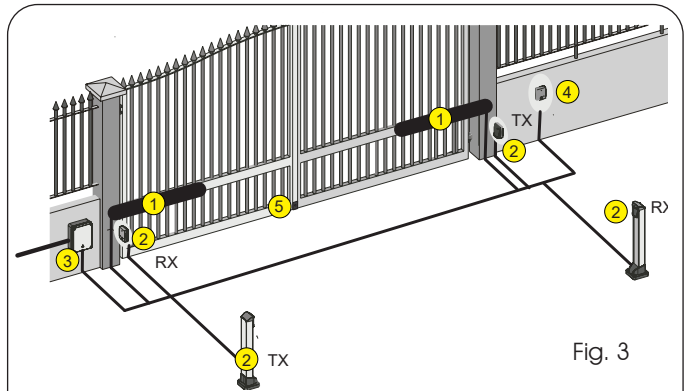

- 1 S450H 2 x AWG 14 (max length 30 ft)
 AWG 12 (max length 50 ft)
 AWG 10 (max length 100 ft)
- Encoder 2 x AWG 20
- 2 RX Photocells (receiver) 4 x AWG 20
- 2 TX Photocells (transmitter) 2 x AWG 20
- 3 Electronic control unit AC power 3 x AWG 14
- 4 Key-operated push-button 2 x AWG 20
- 5 Electric lock 2 x AWG 14

TECHNICAL SPECIFICATIONS	CBAC OPERATOR		SB OPERATOR
	Power Supply	24 Vdc	
Power Consumption	60 W		
Current	7 A		
Protection Class	IP 55		
Operating Temperature	4°F +131°F (-20 °C +55°C)		
Hydraulic Lock	Installed	Not installed	
Max. Traction/Thrust Force	1124 lbf (500 daN)		
Max Leaf Length	14 ft (4.3 m)	17 ft (5.2 m)	
Max Leaf Weight	1100 lb (500 Kg)		
Duty cycle at 68 °F	Continuous		
Class of Operation	Residential		
Linear Rod Speed	adjustable up to 1 in/sec		
Effective Rod Stroke	12.2 in (311 mm)		
Operator Weight	14.3 lb (6.5 Kg)		

The installer is responsible for providing the main power breaker switch, and for making sure that the entire gate system meets all applicable local electrical codes.

Make sure to locate all controls that operate the gate system at least 6 ft away from any moving parts.

2. INSTALLATION

2.1 Preliminary Checks

Ensure that the following conditions have been met to ensure safety and the efficient operation of the automated system:

- The gate structure must be suitable for automation. Verify that it is sufficiently strong and that its dimensions correspond to those stated in the technical specifications.
- Verify the smooth and uniform movement of leaves, without irregular friction during the entire travel.
- Verify hinges are in good working order.
- The gate swings level.

2.2 Installation Dimensions With Bracket Fastened To The Column

ATTENTION: do not cut the rear bracket for any reason.

Refer to Figures 4 and 5 and Table 1 to determine the installation position of the operator.

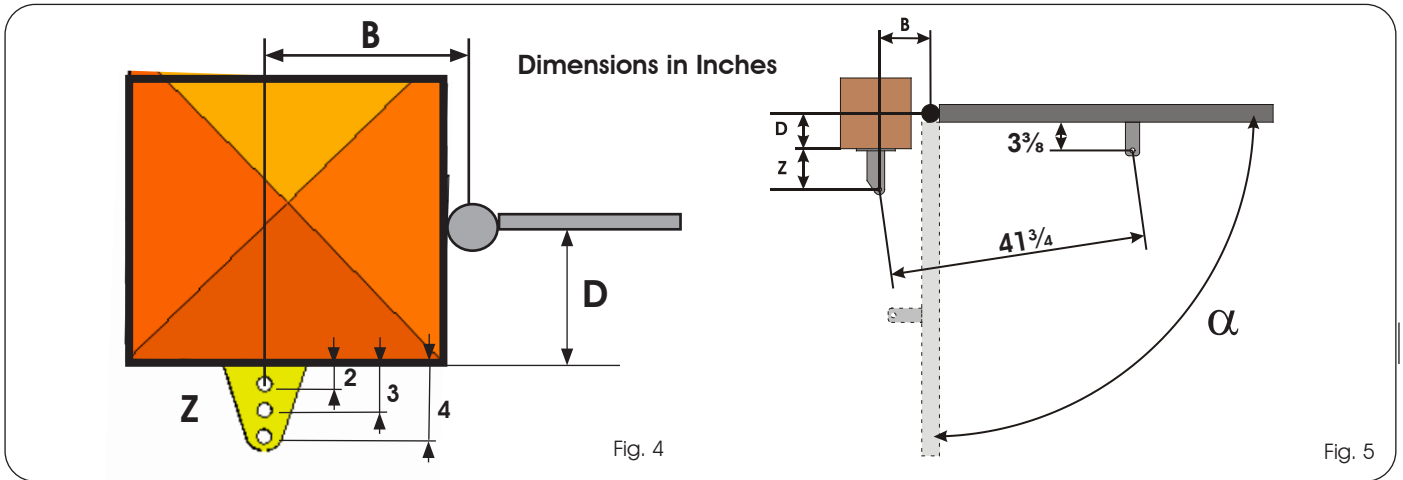

Fig. 4

Fig. 5

INSTALLATION DIMENSION "B"
(SEE FIGURES 4 and 5)

TAB. 1		B	
		XXX	XXXX
INSTALLATION DIMENSION "D" (SEE FIGURE 5)	XXX	120° (3)	120° (3)
	XXX	110° (2)	110° (2)
	XXX	115° (1)	110° (1)

α° (3) (3)
 HOLE TO BE USED ON THE REAR BRACKET
 α° (2) (2)
 α° (1) (1)

- INTERSECT THE DIMENSIONS "D" AND "B" TO OBTAIN THE MAXIMUM VALUE OF OPENING ANGLES.
- ATTENTION: USE POSITIVE STOPS IN ORDER NOT TO EXCEED THE MAXIMUM OPENING ANGLES STATED IN TABLE 1 AND GUARANTEE THE CORRECT OPERATION OF THE AUTOMATED SYSTEM.

TAB. 1		B									
		2.95-3.3	3.35-3.7	3.75-4.0	4.1-4.45	4.5-4.85	4.9-5.25	5.3-5.65	5.7-6.0	6.1-6.45	6.5-6.85
D	0.75-0.95					110° (3)	110° (3)	115° (3)	108° (3)	100° (3)	100° (3)
	1.0-1.3					108° (3)	110° (3)	110° (3)	103° (3)	100° (3)	94° (3)
	1.35-1.7				100° (3)	107° (3)	108° (3)	104° (3)	111° (2)	104° (2)	100° (2)
	1.75-2.1				100° (3)	105° (3)	106° (3)	100° (3)	106° (2)	100° (2)	96° (2)
	2.15-2.5			97° (3)	100° (3)	105° (3)	99° (3)	107° (2)	100° (2)	96° (2)	92° (2)
	2.6-2.9		93° (3)	97° (3)	100° (3)	100° (3)	110° (2)	101° (2)	96° (2)	102° (1)	98° (1)
	2.95-3.3		90° (3)	95° (3)	100° (3)	105° (2)	102° (2)	111° (1)	105° (1)	98° (1)	94° (1)
	3.35-3.7	90° (3)	90° (3)	95° (3)	100° (2)	104° (2)	96° (2)	104° (1)	100° (1)	94° (1)	90° (1)
	3.75-4.0	90° (3)	90° (3)	95° (3)	100° (2)	96° (2)	106° (1)	98° (1)	96° (1)	90° (1)	
	4.1-4.45	90° (3)	90° (3)	95° (2)	97° (2)	103° (1)	99° (1)	94° (1)	92° (1)		
	4.5-4.85	90° (3)	90° (2)	95° (2)	98° (1)	100° (1)	94° (1)				
	4.9-5.25	90° (2)	90° (2)	95° (1)	98° (1)	94° (1)					
	5.3-5.65	90° (2)	90° (2)	95° (1)	94° (1)						
	5.7-6.0	90° (1)	90° (1)	94° (1)							
	6.1-6.45	90° (1)	90° (1)								
6.5-6.75	90° (1)										

Dimensions in Inches

HOLE TO BE USED ON THE REAR BRACKET

2.3 Installation Dimensions With Bracket Fastened to the Side Wall

ATTENTION: do not cut the rear bracket for any reason. Refer to Figures 4¹ and 5¹ and Table 2 to determine the installation position of the operator.

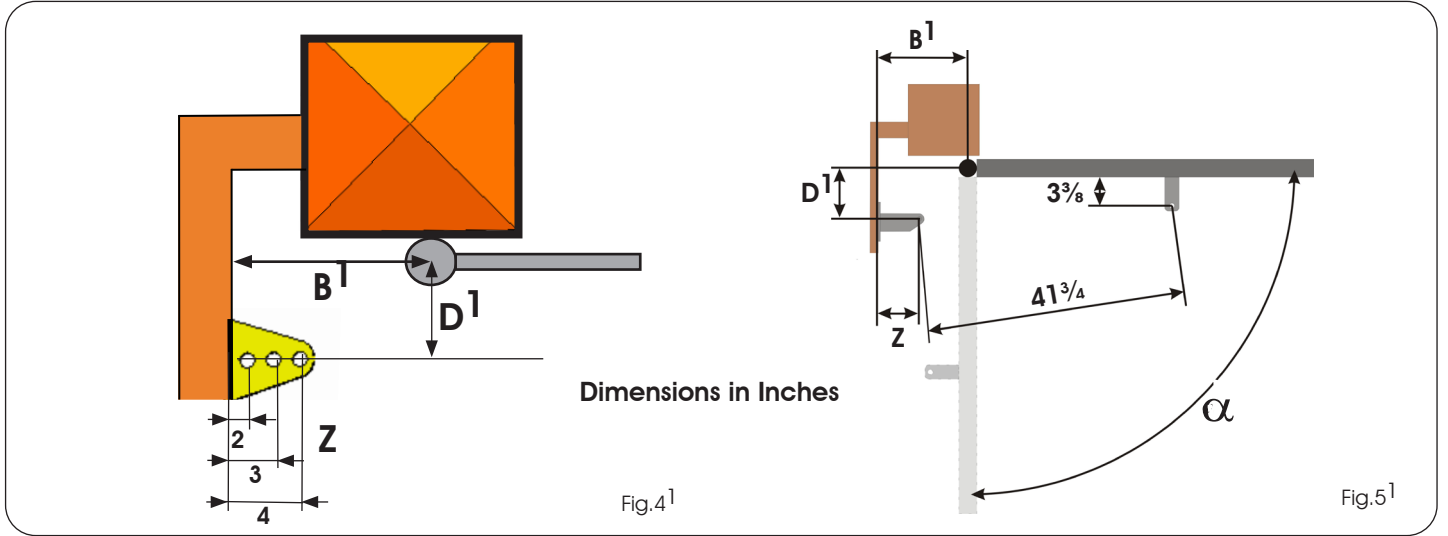

INSTALLATION DIMENSION " B¹ " (SEE FIGURE 4¹-5¹)

Dimensions in Inches

TAB. 2		B¹	
		XXX	XXXX
D¹	XXX	115° (1)	115° (1)
	XXX	110° (2)	110° (2)
	XXX	100° (3)	100° (3)

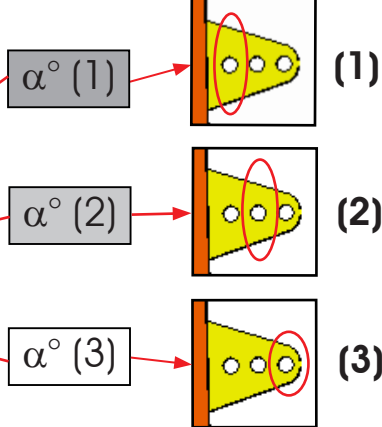

HOLE TO BE USED ON THE REAR BRACKET

- INTERSECT THE DIMENSIONS " D¹ " AND " B¹ " TO OBTAIN THE MAXIMUM VALUE OF OPENING ANGLES.
- ATTENTION: USE MECHANICAL LIMIT SWITCHES IN ORDER NOT TO EXCEED THE MAXIMUM OPENING ANGLES STATED IN TABLE 2 AND GUARANTEE THE CORRECT OPERATION OF THE AUTOMATED SYSTEM.

TAB. 2		B¹														
		5.0-5.25	5.5-5.65	5.7-6.0	6.1-6.45	6.5-6.85	6.85-7.25	7.3-7.65	7.7-8.0	8.1-8.45	8.5-8.8	8.85-9.2	9.25-9.6	9.65-10.05	10.1-10.4	10.45-10.75
D¹	4.75-4.85					110° (1)	110° (1)	115° (1)	108° (1)	100° (1)	100° (1)	108° (2)	100° (2)	100° (2)	100° (3)	100° (3)
	4.9-5.25					108° (1)	110° (1)	110° (1)	103° (1)	100° (1)	94° (1)	103° (2)	100° (2)	94° (2)	100° (3)	94° (3)
	5.25-5.65				100° (1)	107° (1)	108° (1)	104° (1)	100° (1)	96° (1)	92° (1)	100° (2)	96° (2)	92° (2)	96° (3)	92° (3)
	5.65-6.0				100° (1)	105° (1)	106° (1)	100° (1)	96° (1)	90° (1)	100° (2)	96° (2)	90° (2)	96° (3)	90° (3)	
	6.1-6.45			97° (1)	100° (1)	105° (1)	99° (1)	94° (1)	92° (1)	99° (2)	94° (2)	92° (2)	94° (3)	92° (3)		
	6.5-6.85		93° (1)	97° (1)	100° (1)	100° (1)	96° (1)	100° (2)	100° (2)	96° (2)	100° (3)	96° (3)				
	6.85-7.20		90° (1)	95° (1)	100° (1)	96° (1)	95° (2)	100° (2)	96° (2)	100° (3)	96° (3)					
	7.25-7.65	90° (1)	90° (1)	95° (1)	97° (1)	90° (2)	95° (2)	97° (2)	95° (3)	97° (3)						
	7.65-8.0	90° (1)	90° (1)	95° (1)	90° (2)	90° (2)	95° (2)	90° (3)	95° (3)							
	8.0-8.45	90° (1)	90° (1)	90° (2)	90° (2)	90° (2)	90° (3)	90° (3)								
8.5-8.8	90° (1)	89° (2)	90° (2)	90° (2)	90° (2)	90° (3)	90° (3)									

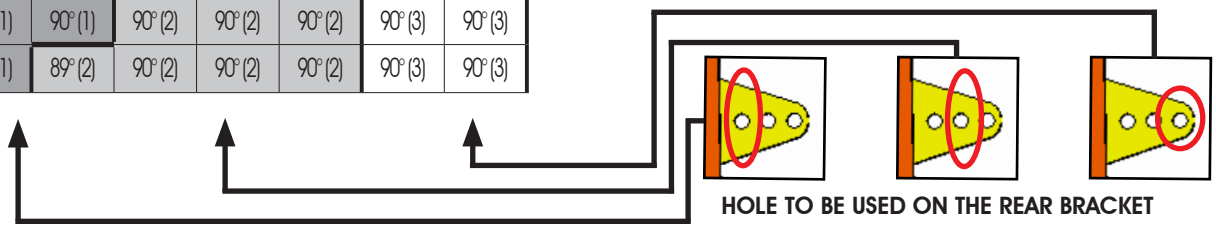

HOLE TO BE USED ON THE REAR BRACKET

2.4 Installation Steps

1. Level then weld the rear bracket to the pillar, or fix it using suitable anchors. Follow the dimensions stated in Tab.1 (never cut the rear bracket; note that it must be installed with the word "UP" facing up as shown in Figure 6 Ref. a).

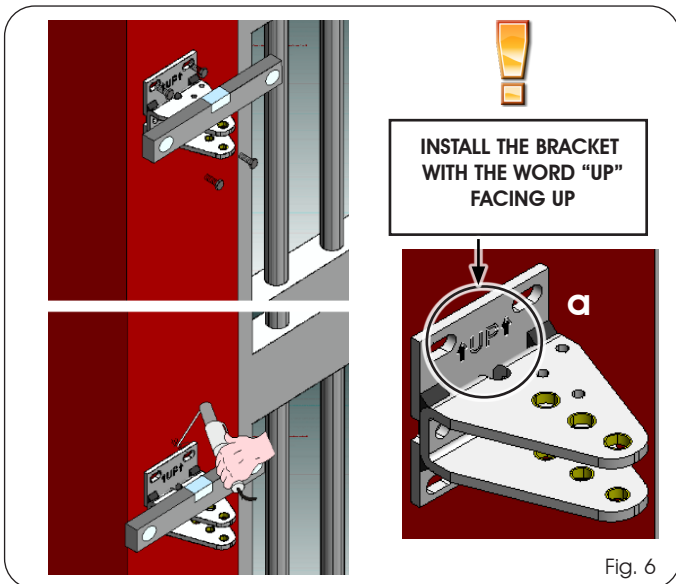

2. Pre-assemble the fork (Fig. 7 ref. a) without tightening the nut. After choosing the hole on the rear bracket (see Table 1, white or grey boxes), install the fork (Fig. 7 ref. b). Secure in place by inserting the special pin supplied (Fig. 7 ref. c), then tighten the nut (Fig. 7 ref. d).

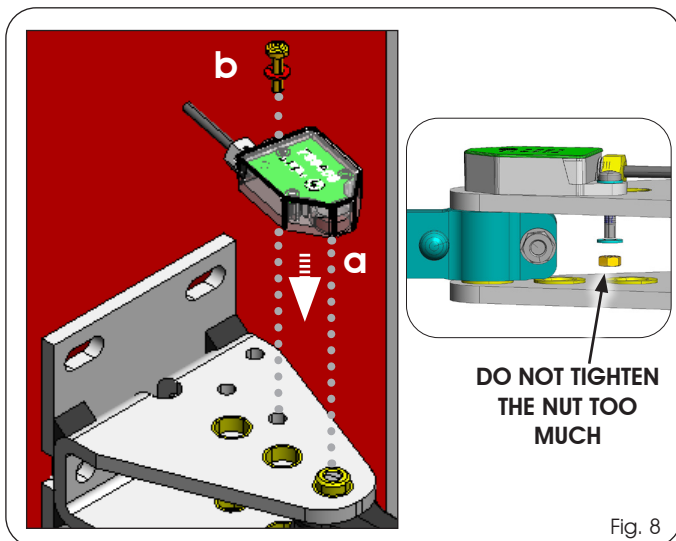
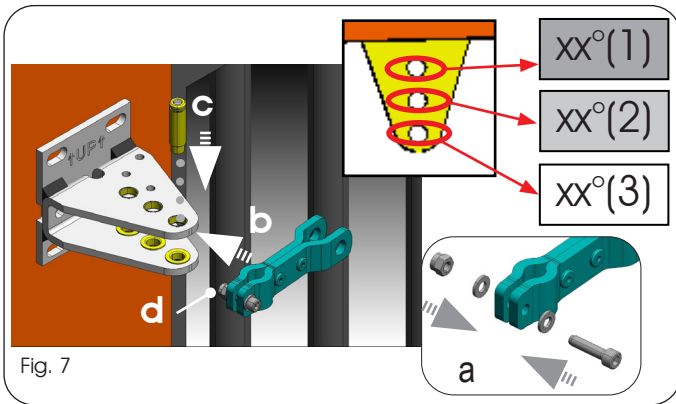

3. Install the encoder on the rear bracket by correctly engaging it on the pin, then attach it with the screw and nut supplied (Fig. 8 Ref. a, b).
4. Slightly press the protection cover on the rear bracket until it locks in position (Fig. 9).



5. Assemble the operator and the rear bracket using the supplied pin and nut (Fig. 10 Ref. a - b).

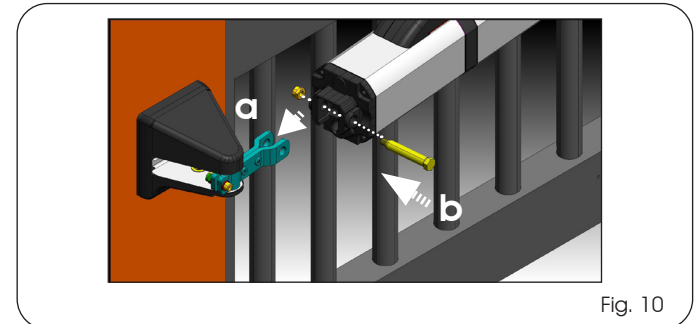

6. Screw the swivel joint halfway into the piston rod (Fig. 11 Ref. a).
7. Unlock the operator according to Section 4.
8. If no external mechanical stop at close is present, you may use the stop point inside the operator (extend the rod completely up to its internal stop point).
9. If an external mechanical stop at close is present, extend the rod completely and then push it back 0.25 in.
10. Close the gate leaf and install the front bracket on the rod as shown in Fig. 11 Ref. b.

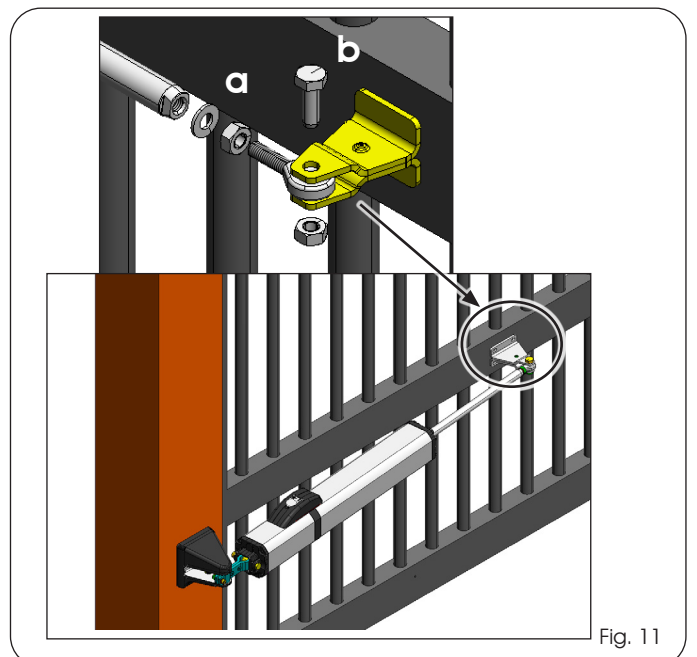

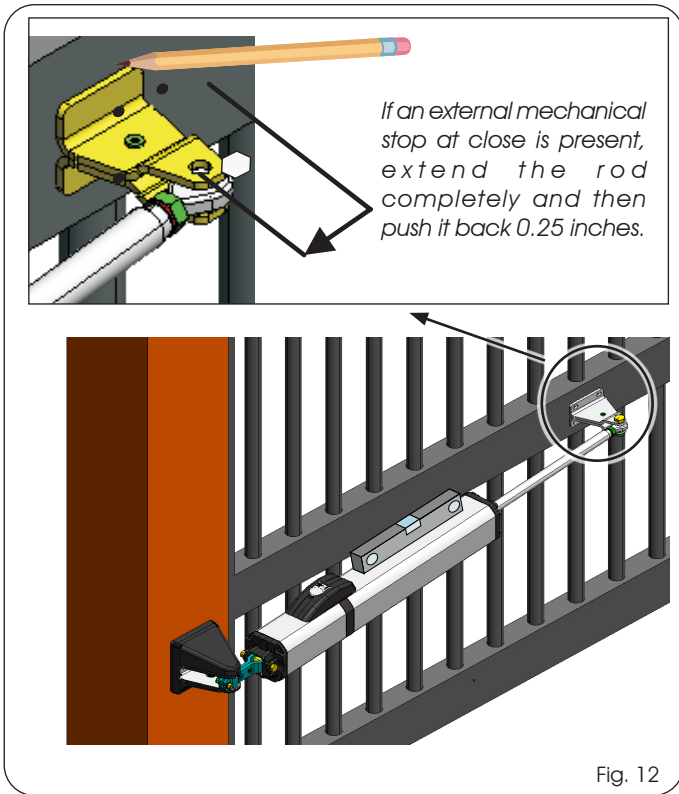

11. Establish the fixing position of the front bracket on the leaf and mark the fixing points (Fig. 12) (the operator must be perfectly level).
12. Remove the operator from the front bracket to avoid damaging the rod when the front fixing is attached on the gate.
13. Weld the front bracket directly on the leaf or attach it with threaded inserts (Fig. 13)
14. If an opening mechanical stop on the ground is not installed, spacers can be used (Fig. 1 Ref. 7). Remove the front articulated joint and insert the spacers required (Fig. 14).

IMPORTANT: Overlapping bi-part gates must stop on their positive stops, one operator cannot be the stop for both gates

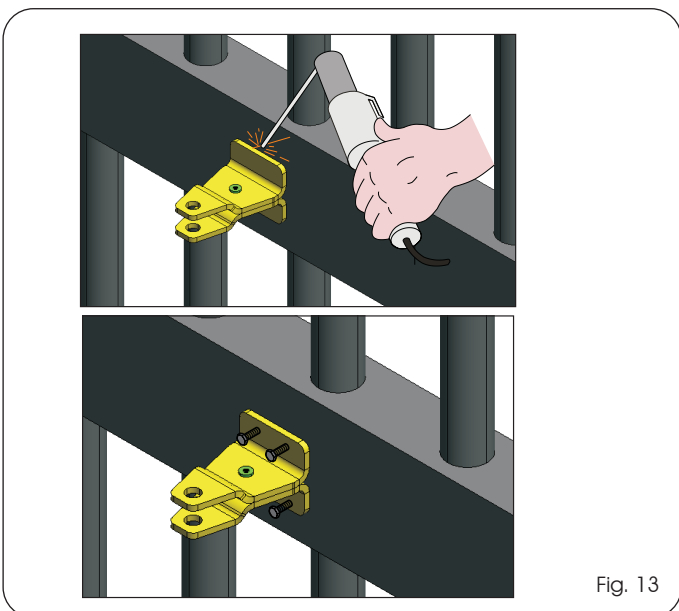

15. Attach the operator to the front bracket (Fig. 15).
16. Remove the bleed screw (Fig. 16 Ref. a) paying special attention to leave the sealing O-Ring in place.
17. Install the metallic protection cover as shown in Fig. 16, insert and tighten both tie-rods.
18. Connect the cable to the operator using the two screws supplied, as shown in Fig. 17. Push the cord by hand, then tighten the screws

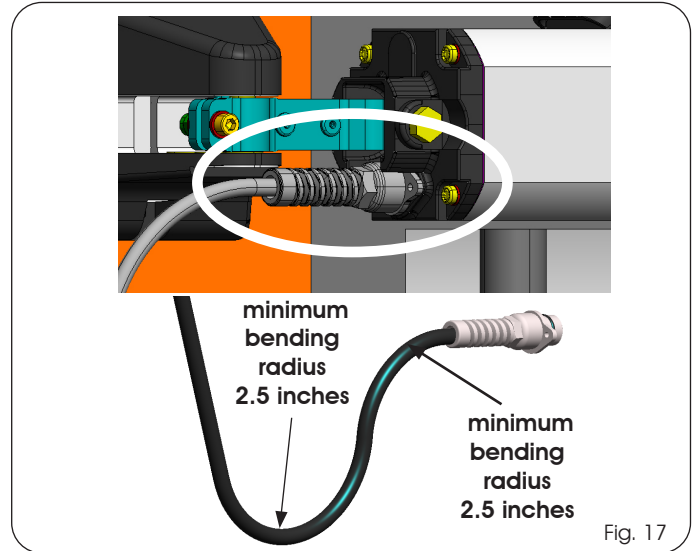
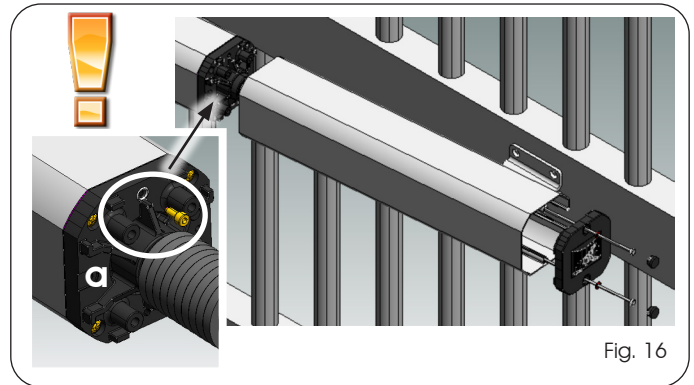
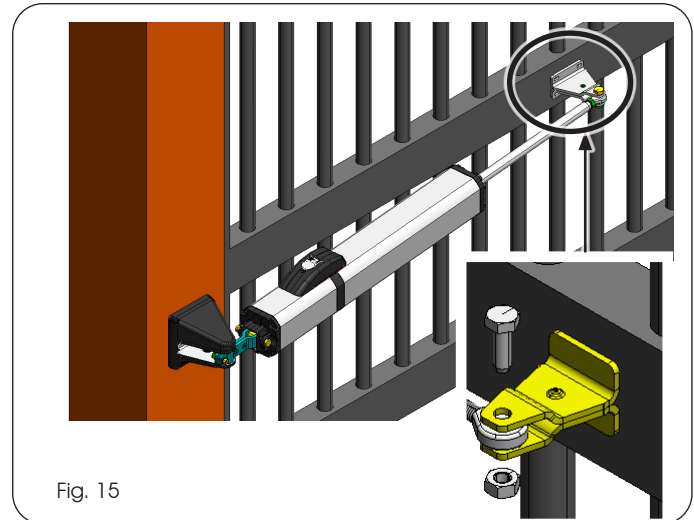
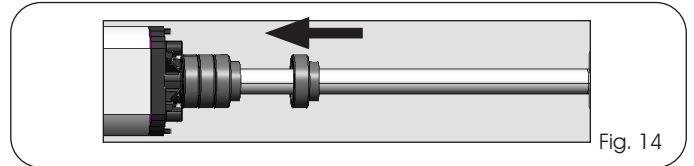

3. MANUAL OPERATION

If the gate is to be operated manually because of a power failure or an automated system fault, activate the release device.

1. Lift the protection lid (Fig. 18, Ref. a) and insert the key in the lock (Fig. 18, Ref. b).
2. Turn the key 90° clockwise to open the cover and lift it.
3. Turn the release knob (Fig. 18, Ref. c) counter-clockwise until it stops.
4. Open or close the leaf manually.

To restore the normal operation of the automated system, perform the above described operations in reverse order. Make sure to not overtighten the red knob as it is designed to strip before damaging the operator.

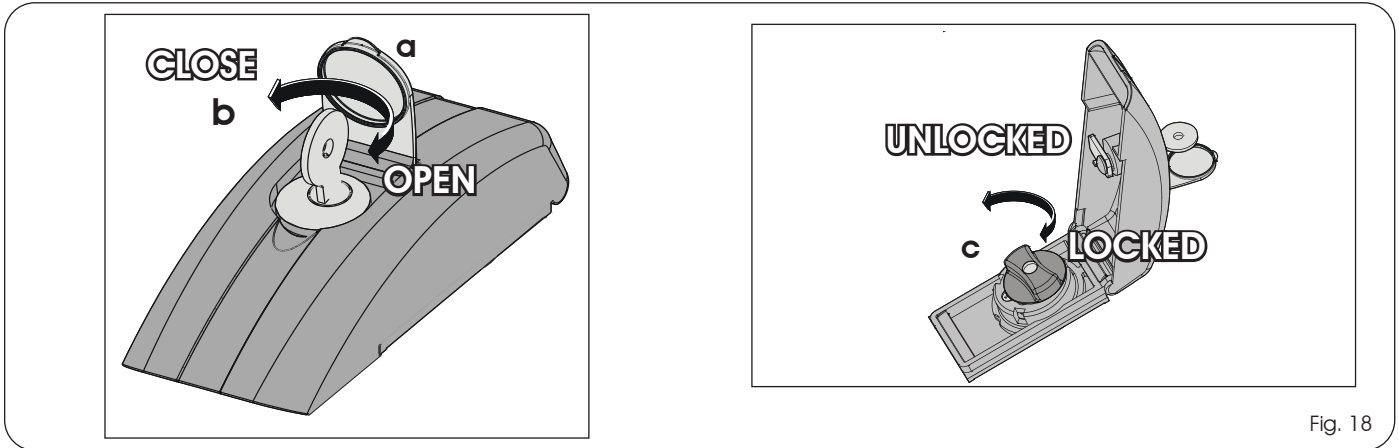

Fig. 18

NOTE: The model S450H SB with no hydraulic locks doesn't have a manual release mechanism. You do not need to release the operator to manually move the leaf.

4. ENCODER CONNECTIONS

The S450H operator is equipped with an encoder system. The proper assignment of the leaf to the corresponding encoder depends on the connection of the two encoder wires (leaf 1 - encoder 1; leaf 2 - encoder 2).

the encoder wires must be connected to the bus connector of the E024U control board.

To verify the proper combination **LEAF 1 - ENCODER 1 - MOTOR 1** and **LEAF 2 - ENCODER 2 - MOTOR 2**, refer to the LEDs on the encoders, as shown in Table 3 and Figures 19, 20 and 21.

To invert the leaf-encoder combination, change the encoder polarity by swapping its wires until the right LEDs are lit.

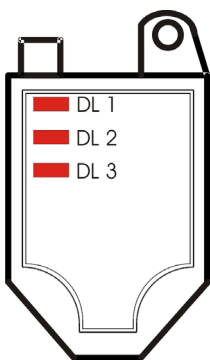

DL 1: must always be ON to ensure the right connection between encoder and board.
 DL 2: identifies the leaf to which the encoder is installed.
 If the encoder is installed on leaf 1, the DL 2 LED is ON.
 If the encoder is installed on leaf 2, the DL 2 LED is OFF.
 DL 3: when blinking at regular intervals, it signals the pulse reading during the leaf movement. When the gate leaf is stationary, DL 3 is OFF.

NOTE: The LEDs on the encoder also remain visible when the rear bracket protection cover is installed.

TABLE 3			
LED	ON	BLINKING	OFF
DL 1	Power supply ON and BUS - board communication	Power supply ON but no BUS communication (e.g.: cabling fault)	Power supply OFF and no BUS communication (e.g.: missing or broken connection)
DL 2	Encoder associated to leaf 1	/	Encoder associated to leaf 2
DL 3	/	Pulse reading during leaf movement	Leaf stationary

5. BLEEDING

1. Loosen the tie-rods (Fig. 23 ref. a) and remove the metal protective housing (Fig. 23 ref. b).

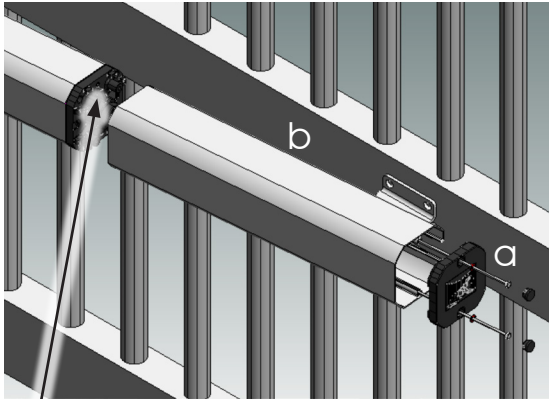

Remove the upper tie-rod and be careful with the O-ring that must remain in its seat.

Fig.23

2. Remove the screw in Fig. 24 ref.d from the front bracket
3. Remove the swivel joint (Fig.24 ref.f) from the piston. (Fig. 24 ref. g).

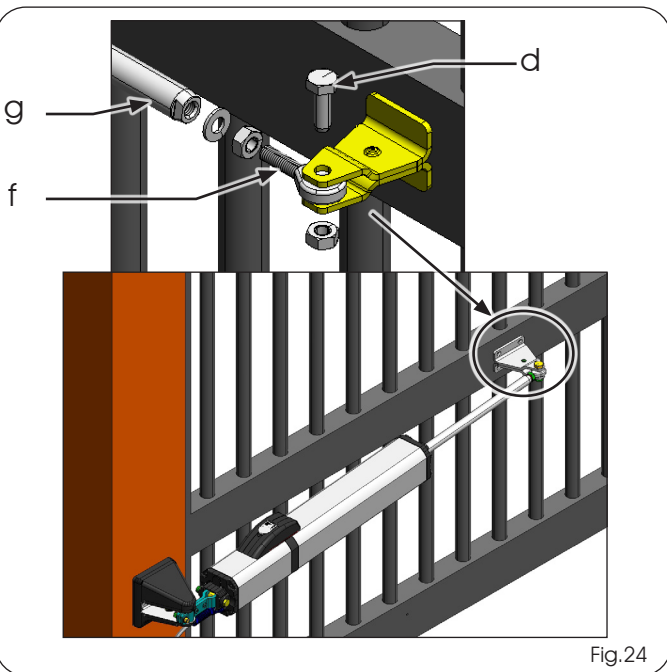

Fig.24

4. Remove all spacers, if present (Fig. 25).

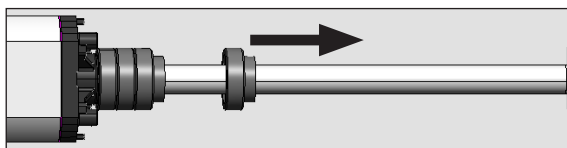

Fig.25



To prevent oil leakage from the breather hole, do not tilt the operator downward

Fig.26

5. Tilt the operator upward as much as possible. Do not force the rear fitting too much.
6. Power the operator off the batteries and repeatedly move the piston in and out, over its complete stroke, until reaching a smooth movement (Fig. 27).

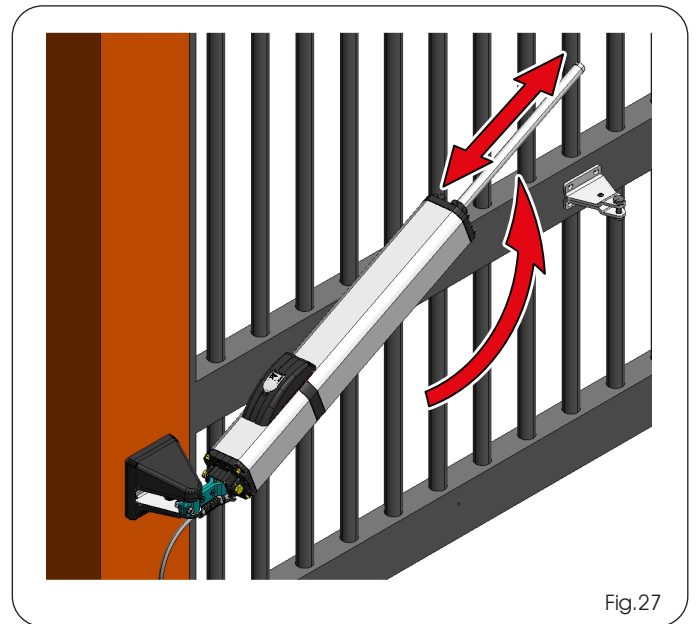

Fig.27

7. After bleeding, repeat the operations described above in reverse order to reinstall the operator on the gate.

6. PERIODIC PRESSURE RELIEF

In case the operator could be subject to wide temperature swings while stationary set Dip Switch **DS2** on the control board as this:



The motor will run briefly every hour to release any extra pressure that has accumulated

E024U CONTROL BOARD

1. DESCRIPTION & CHARACTERISTICS

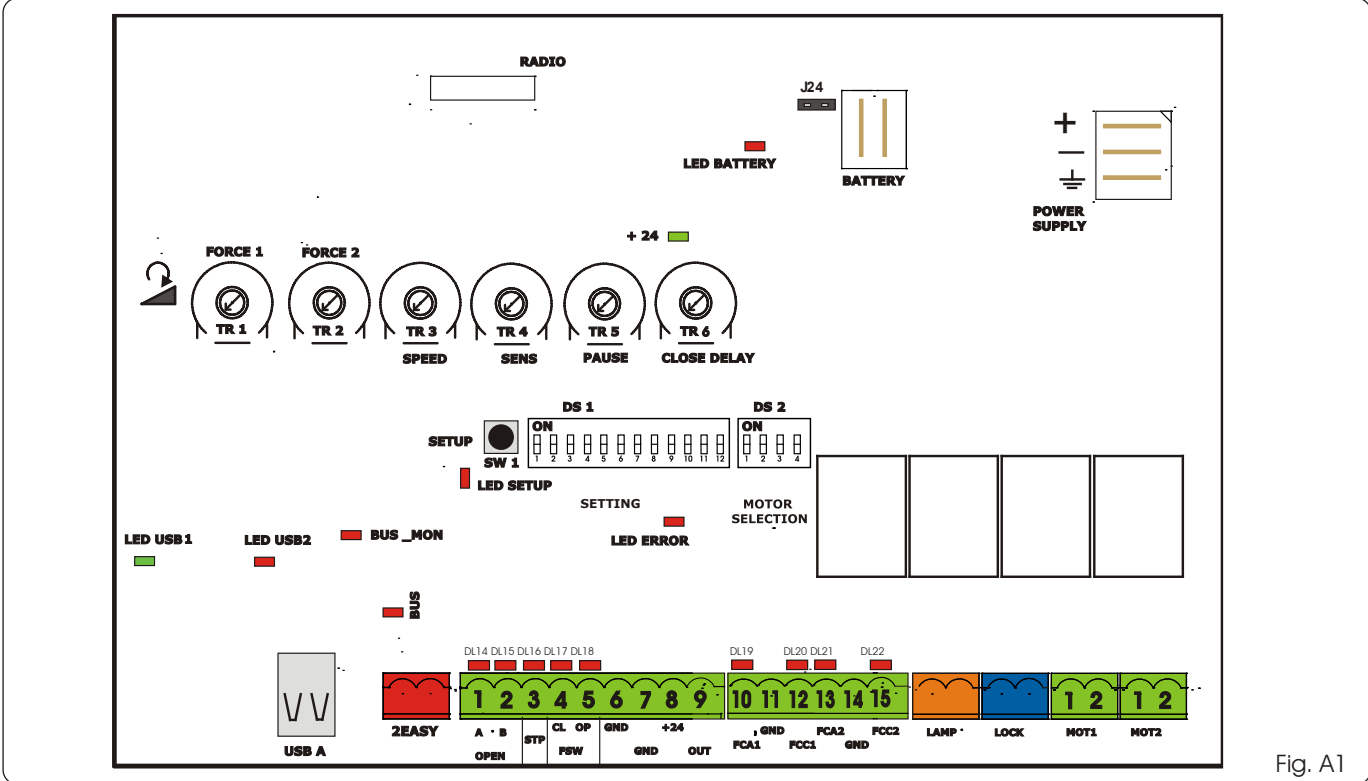

Fig. A1

TECHNICAL SPECIFICATIONS

Main power supply	115 V~ 50/60 Hz
Secondary power supply	24 Vdc - 16 A max. (min. 20 Vdc. - max. 36 Vdc.)
Power consumption	stand-by = 1.5W max. = 400 W
Max load per motor	7 A
Accessory power	24 Vdc - 500 mA max
Battery charge current	150 mA
Operating temperature	-4 °F +131 °F (-20 °C +55 °C)
Protection fuses	All self-resetting
Main power fuse	6.3 A Timed
Operating Logics	E, A, S, EP, AP, SP, B, C
Operating time out	10 min.
Pause time	Programmable (0 to 4 min)
Motor force, speed, obstacle sensitivity, closing delay	Programmable with dedicated trimmer
Connector inputs	Power supply, Battery, Radio receiver, USB
Terminal strip inputs	Encoder, Open A, Open B, Stop, Open safety photocell, Closing safety photocell, Limit switches
Terminal strip outputs	Audio Alarm, Lock, Motors, Accessory power supply
Programming	With trimmers, dipswitches and pushbutton

RADIO	Connector for the radio receiver
BATTERY	Connector for the backup battery
J24	Jumper to disable battery charging (With the jumper present the battery charger is enabled)
POWER SUPPLY	DC Power supply input
TR1 to TR6	Programming Trimmers
+24 LED	DC power indicator
SW1 - SETUP	Pushbutton for automatic setup
DS1 - DS2	Programming dipswitches
LED ERROR	Troubleshooting indicator
USB A	USB connection for software upgrade

RADIO CONNECTION

On the radio connector it's possible to plug in receivers RP and RP2. With a single channel radio RP it will be possible to activate only the OPEN A input, with a dual channel radio RP2 it will be possible to activate both OPEN A and OPEN B inputs. Plug in the radio board with the component side towards the internal part of the board.

 Make sure you insert or disconnect the board ONLY with the power off.

NOTE: This manual refers to firmware version 1G. The version is shown with the number of flashes of LED USB1 at power up. Version 1G = 5 flashes.

2. INPUTS / OUTPUTS DESCRIPTION

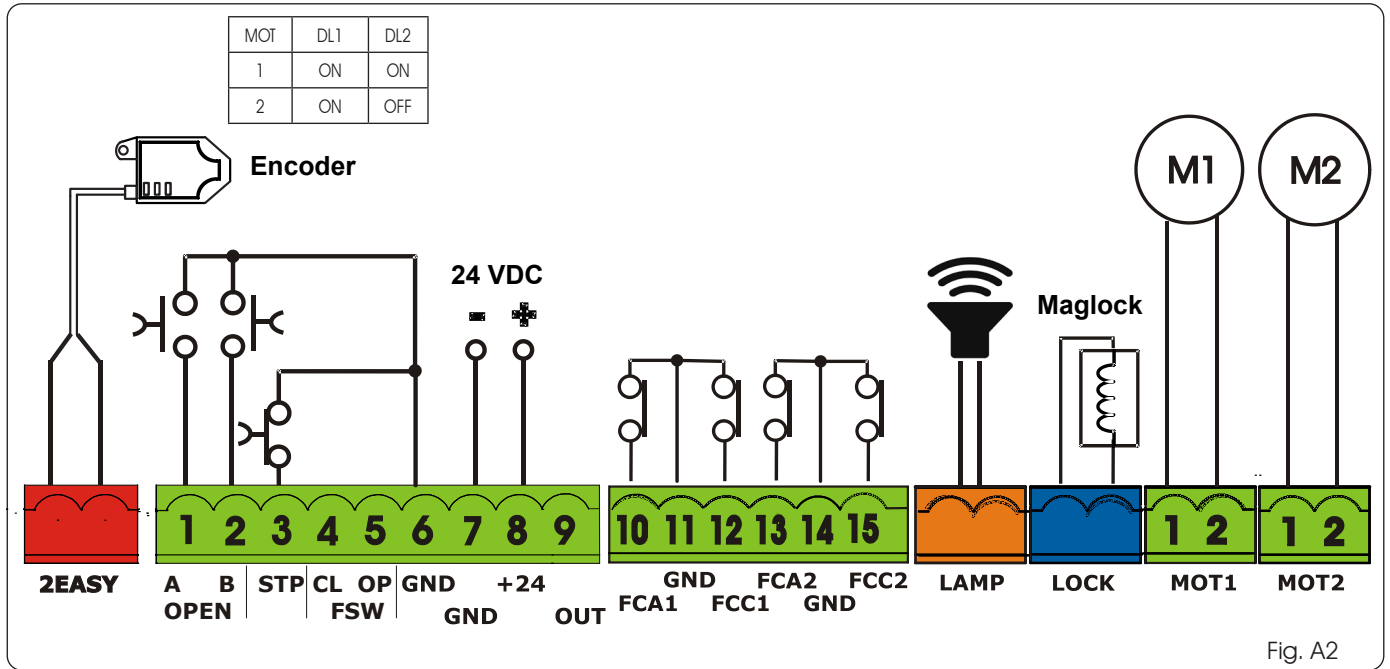

Fig. A2

PIN	LABEL	FUNCTION
2 EASY	2 EASY	2easy BUS input for encoders (S800H and S450H only), XIB and loop detector boards
1	OPEN A	N.O. Contact for total opening command
2	OPEN B / CLOSE	OPEN B: N.O. Contact for opening of leaf 1 only (with only one leaf the opening stops at 50% of traveling) CLOSE (LOGIC B-C): N.O. Contact for closing command
3	STOP	N.C. Contact for stop command
4	FSW CL	N.C. Contact for closing safety
5	FSW OP	N.C. Contact for opening safety
6	GND (-)	24 Vdc negative
7	GND (-)	24 Vdc negative
8	+ 24	24 Vdc positive
9	OUT (-)	24 Vdc negative for safety TX photocell (monitored)
10	FCA 1	Open limit switch Motor 1
11	GND (-)	24 Vdc negative
12	FCC 1	Close limit switch Motor 1
13	FCA 2	Open limit switch Motor 2
14	GND (-)	24 Vdc negative
15	FCC2	Close limit switch Motor 2
LAMP	LAMP	Audio Alarm output
LOCK	LOCK	Output for electrical lock, max 5A pulse (DS2 - SW 4=OFF) 12 Vac / 24Vdc Always ON (maglock); max 1 A (DS2 - SW 4=ON) 24 Vdc
MOT1	MOT 1	Motor 1 output (first moving motor)
MOT2	MOT 2	Motor 2 output (second moving motor)
USB A	USB	Firmware upgrade input

3. SAFETY DEVICES CONNECTIONS

Entrapment protection

To comply with the UL325 standard for gate operators every entrapment zone, as defined in ASTM F2200, must be protected by two independent entrapment protection devices. One of the devices is inherent in the E024U control boards design, the other can be external, like a photocell or an edge sensor.

See this picture for the photocells positioning:

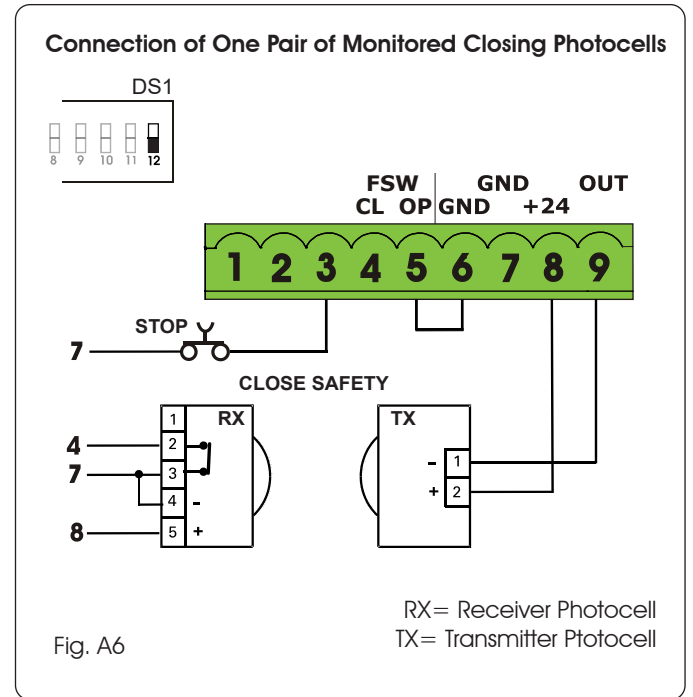
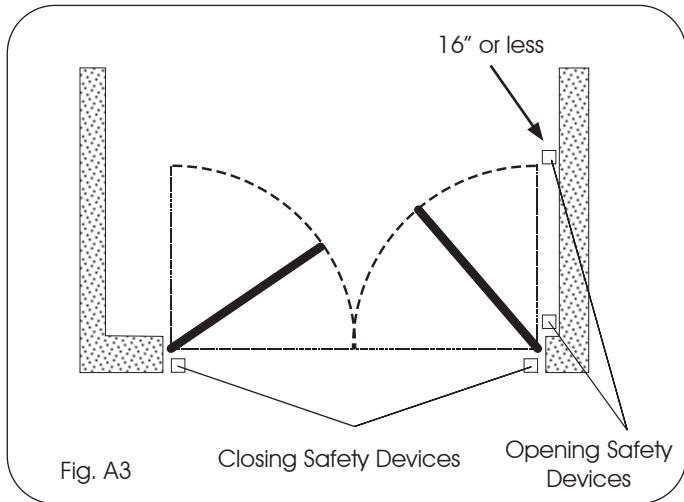

Opening Safety Devices:

Are active only during the gate opening movement, and are suitable for protecting the area between the opening leaves and fixed obstacles (walls, etc) against the risk of entrapment

Closing Safety Devices:

Are active only during the gate closing movement, and are suitable for protecting the closing area against the risk of entrapment.

Monitored Devices:

Additionally the UL325 standard requires that every external entrapment protection device must be monitored for presence and correct operation. To comply with this requirement the E024U control board uses the FAILSAFE function. This function tests the photocells before each movement of the operator. In case the test fails the movement is inhibited. This function is enabled by default on the Closing Safety Input and can be enabled on the Opening Safety Input using dip-switch 12 of DS1 ON.

The power supply negative of the transmitter must be connected to the OUT pin (No.9).

See Fig. A6, A7, A8, A10 for wiring examples.

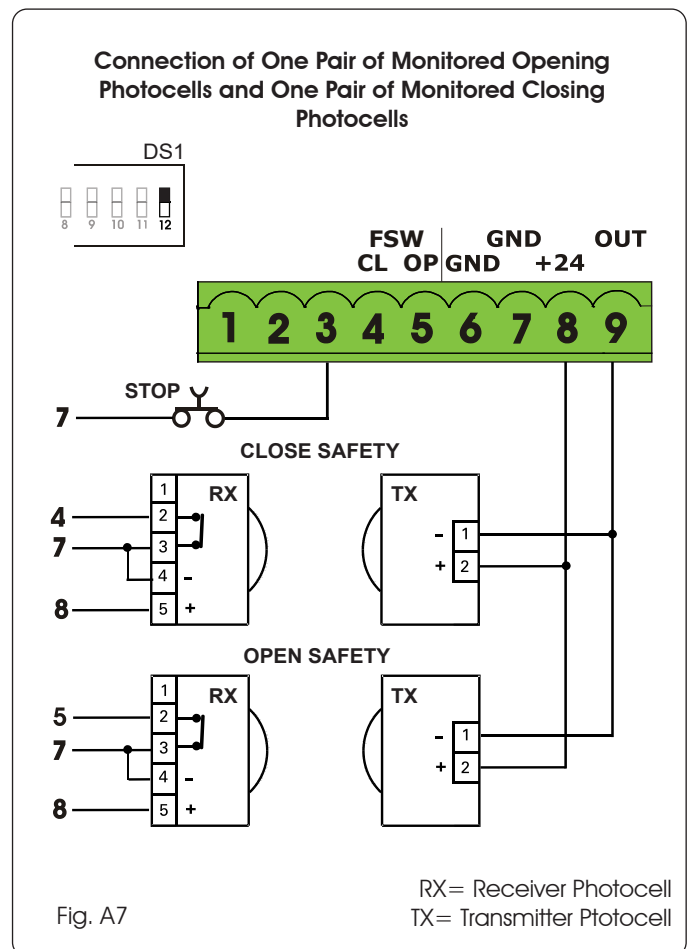

Only one monitored photocell can be connected to the Closing or Opening safety inputs. More than one photocell or other device can be connected to the safety inputs, but they will not be monitored.

Other devices connected to the safety inputs must have normally closed contacts and wired in series with the main monitored sensor.

See the following example of one closing safety monitored photocell and one non monitored one.

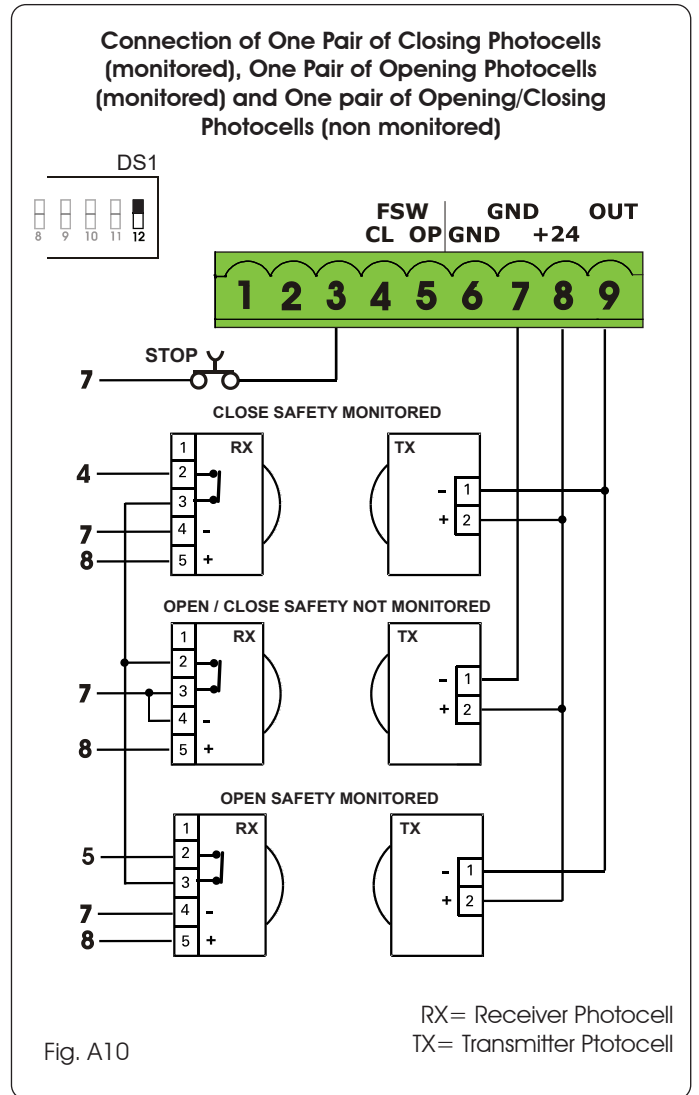
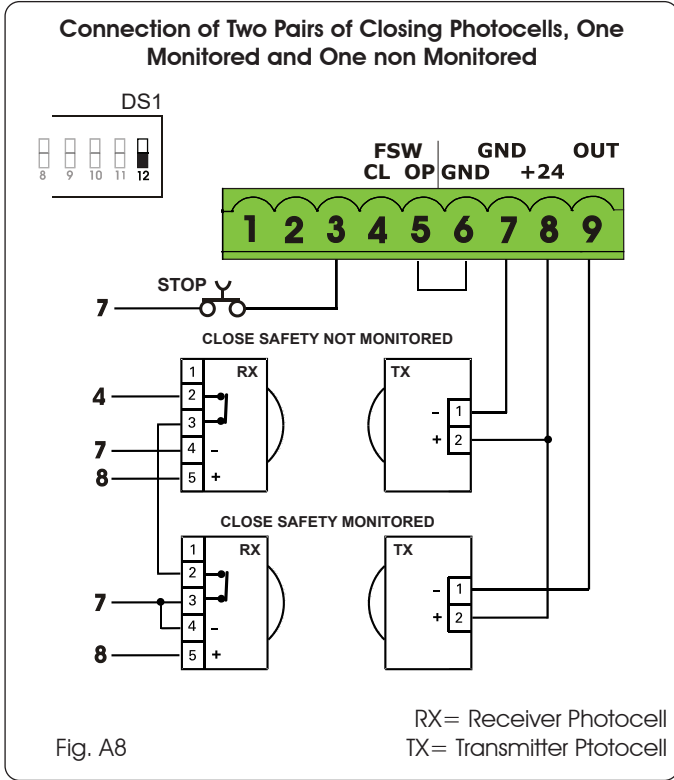

Opening/Closing Safety Devices:

They operate during the gate opening and closing movements and are suitable to protect the opening and closing areas against the risk of impact. Typically these photocells work in combination with other monitored photocell protecting closing or opening entrapment zones. In that case they can't be monitored so they can only protect against potential impact on vehicles.

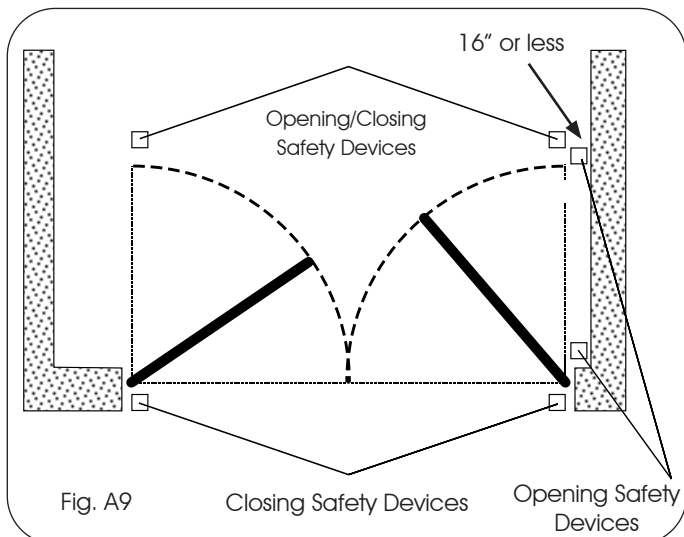

4. PROGRAMMING

DIP SWITCH DS1 SETTINGS FOR OPERATING LOGIC

OPERATING LOGIC					
DS 1: SW 1 - SW 2 - SW 3					
LOGIC	SW 1	SW 2	SW 3	PAUSE TIME	DESCRIPTION
E (default) Semiautomatic	OFF	OFF	OFF	NO	One command opens, the next one closes. A command during opening stops the gate
A Automatic	ON	ON	ON	0 - 4 min	One command opens, waits for the pause time and then closes automatically
S Security	OFF	OFF	ON	0-4 min	One command opens, waits for the pause time and then closes automatically. If the closing safety is activated or another command is given during the pause time it closes. A maintained open command will not hold the gate open
EP Semiautomatic step by step	OFF	ON	OFF	NO	One command opens, the next one closes. During the movement a command stops the gate
AP Automatic step by step	OFF	ON	ON	0-4 min	One command opens, waits for the pause time and then closes automatically. A command during the pause time holds the gate open
SP Security step by step	ON	OFF	OFF	0-4 min	One command opens, waits for the pause time and then closes automatically. If the closing safety is activated during pause time the gate closes in 5 s. A command during pause time holds open the gate
B Manned Pulsed	ON	OFF	ON	NO	An open A command opens the gate, an open B command closes the gate
C Manned Constant	ON	ON	OFF	NO	Holding open A active opens the gate, holding Open B active closes the gate

For more details on the operating logics please refer to Chapter 11 - Function Logics

ADJUSTING TRIMMERS

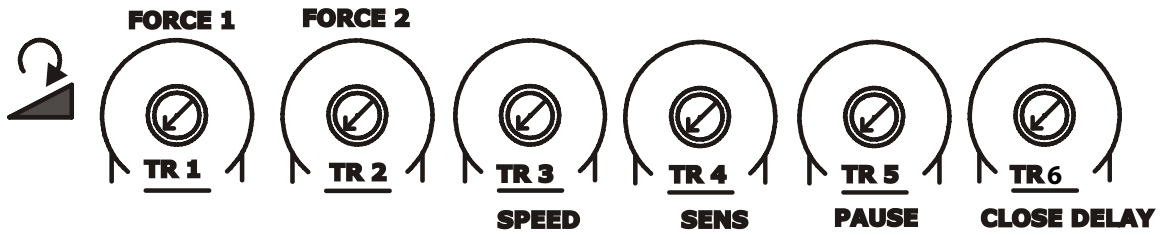

TR 1 – FORCE ADJUSTMENT MOTOR 1
Turn clockwise to increase the opening and closing force

TR 2 – FORCE ADJUSTMENT MOTOR 2
Turn clockwise to increase the opening and closing force

TR 3 – SPEED ADJUSTMENT FOR MOTOR 1 AND MOTOR 2
Turn clockwise to increase the opening and closing speed

TR 4 – SENSITIVITY ADJUSTMENT FOR OBSTACLE DETECTION FOR MOTOR 1 AND MOTOR 2
Turn clockwise to increase the sensitivity for obstacle detection.

See Par. 6.3 for more details about the obstacle detection feature

TR 5 – PAUSE TIME ADJUSTMENT (0 - 4 min.)
Turn clockwise to increase the pause time.

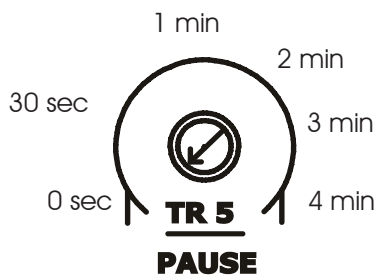

Dip switches DS1: 1 to 3 need to be set for an operating mode with PAUSE time for this adjustment to have any effect

TR 6 - CLOSING DELAY OF LEAF 1 OVER LEAF 2 ADJUSTMENT (0 - 15 sec)
Turn clockwise to increase the delay

DIP SWITCH DS1 SETTINGS FOR BOARD SETUP



BOARD SETUP		
DS 1: SW 4 to SW 12		
OPENING DELAY	SW 4	The opening of leaf 2 is delayed after the opening of leaf 1. This is to avoid the gate leaves interfering with each other during the initial part of the movement. In case there is only one leaf it has no effect.
0 sec (default)	OFF	
2 sec	ON	
REVERSE AND LAST STROKE	SW 5	If active, before opening, while the gate is closed, the motors thrust to close for 2 s to facilitate the release of the electric lock. At closing the motors are activated for a final stroke after slowdown to facilitate locking of the electric lock.
inactive (default)	OFF	
active	ON	
MAX THRUST AT STARTUP	SW 6	With this function active the motors work at maximum force at startup (regardless of the force setting) during the initial phase of the movement. Useful for heavy leaves
inactive (default)	OFF	
active for 3 sec	ON	
AUTOMATIC OPENING IN CASE OF POWER FAILURE	SW 7	If active and with the optional backup battery installed, the board will open the gate after one minute from the power failure and keep it open. Within the minute wait it's always possible to open and close the gate with a command. If the logic used has a pause time the board will close the gate when the power comes back.
inactive (default)	OFF	
active	ON	
CLOSING SAFETY LOGIC	SW 8	With this function you can choose the behavior of the closing safety. With SW8 OFF the gate movement will be reversed as soon as the safety is active, with SW8 ON the gate will stop when the safety is active and it will reverse only when the safety is deactivated.
immediate reverse (default)	OFF	
reverse when cleared	ON	
SHADOW LOOP CONFIGURATION	SW 9	Selects the behavior of the shadow loop function of the Shadow Loop or Loop Detectors Interface accessories. OFF: The shadow loop input is active only before a closing command, ignored in any other conditions ON: The shadow loop input is active before a closing and before an opening command. If an open command is given and the shadow loop input is engaged the open command will be ignored even after the shadow loop input goes inactive. NOTE: On the first power up of the board an open command will be always executed (even if the shadow loop is engaged), but at reduced speed.
active only on closing (default)	OFF	
active on closing and opening	ON	
LOCK OUTPUT CONFIGURATION	SW 10	Selects the behavior of the LOCK output: OFF: The lock output can drive a maglock or a strike lock (see DS2) ON: The lock output indicates the gate status or drives a warning light (see DS2)
the output drives a regular lock	OFF	
gate status or warning lamp	ON	
24V ACCESSORY VOLTAGE	SW 11	Selects the behavior of the 24V accessory voltage during battery mode: OFF: The accessory voltage and BUS input are turned off in battery backup mode ON: The accessory voltage and BUS input are always active even in battery backup mode
24V OFF in Battery Mode	OFF	
24V ON in Battery Mode	ON	
FAIL SAFE MODE	SW 12	Selects the behavior of the Fail Safe (monitoring) mode: OFF: Fail Safe is active on the closing safety photocell input (FSW CL) only ON: Fail Safe is active on both closing safety photocell input (FSW CL) and opening safety photocell input (FSW OP) NOTE: if using the XIB interface the opening safety on it is also monitored. Refers to the XIB manual for further details.
Closing Safety	OFF	
Closing and Opening Safety	ON	

DIP SWITCH DS2 SETTINGS FOR OPERATOR TYPE AND LOCK MODE

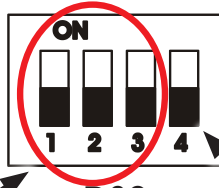

IMPORTANT

DS 2			
OPERATOR SELECTION			
OPERATOR TYPE	SW 1	SW 2	SW 3
S450H (pressure relief)	ON	ON	OFF
S450H, S800H	OFF	OFF	OFF
S418	OFF	OFF	ON
415, 390, 770	ON	OFF	OFF

DS 2		
LOCK OUTPUT MODE		
	OUTPUT MODE	SW 4
DS1-10 OFF	Active only for 3 sec. after an open impulse (from gate closed)	OFF
	Active always except 3 sec. before an opening	ON
DS1-10 ON	Indicates the gate status: Active if the gate is Open or in Pause. Not active in all other states	OFF
	Warning light output with no pre-flashing. Warning lamp will be flashing while gate is moving	ON

5. LED DIAGNOSTICS

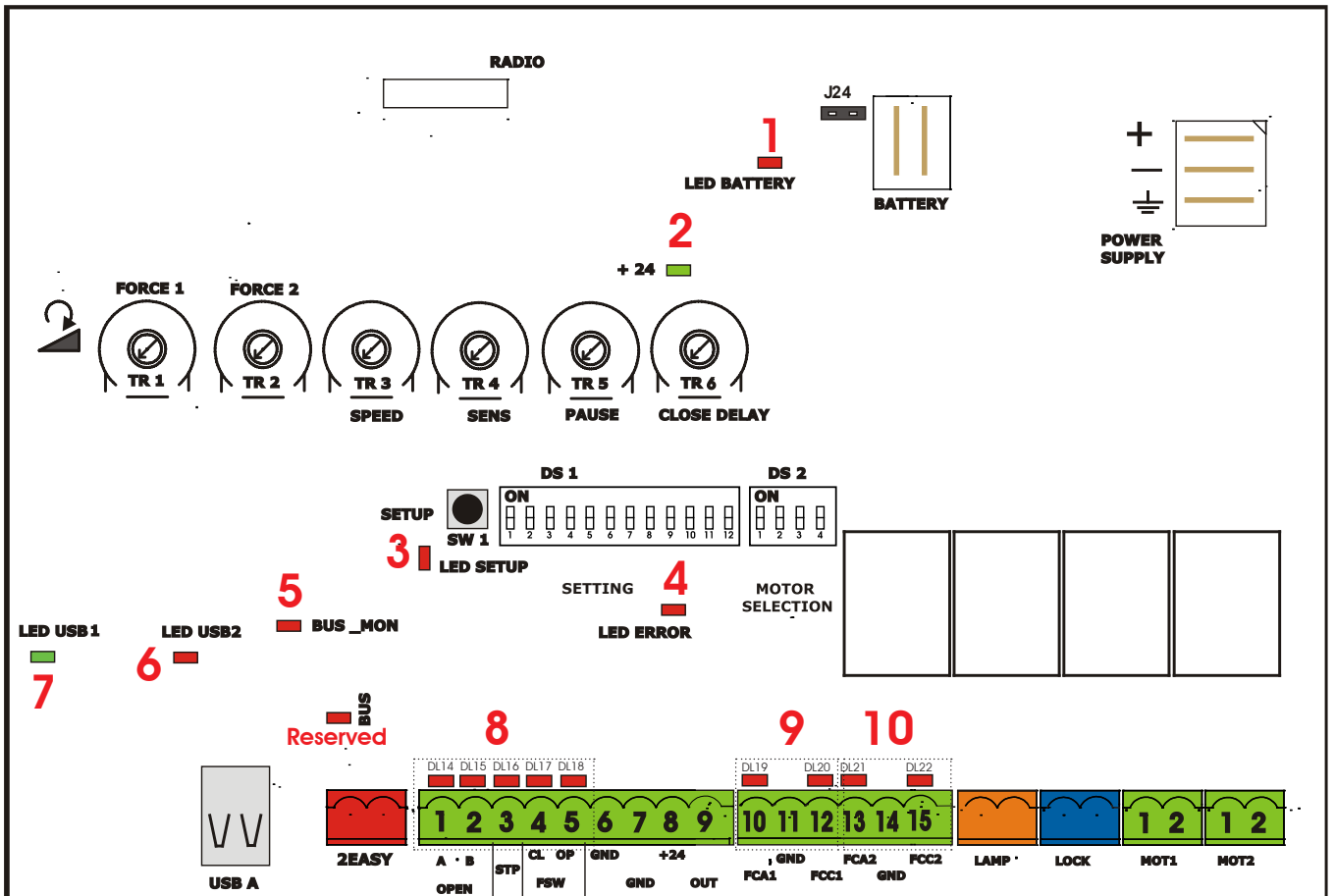

LED	DESCRIPTION	LED STATUS		
		In BOLD the normal state with gate closed and working		
		ON STEADY	OFF	BLINKING
1	LED BATTERY	Board working on AC power	Board working on battery power or ext supply	Battery charging
2	LED +24	Main power present	Main power OFF	
3	LED SET-UP		Normal operation	SLOW BLINK (1 sec. ON - 1 sec. OFF) SET-UP needed
				FAST BLINK (0.5 sec. ON - 0.5 sec OFF) SET UP in in progress
4	LED ERROR	Board malfunction. See possible causes below	No errors	Error conditions. See LED ERROR DISPLAY table
5	LED BUS_MON	Communication on Bus "2easy" OK	Communication bus "2Easy" inactive. Verify encoders for shorts	"2Easy" bus devices with the Same address. Verify encoder LEDs
6	LED USB2		Software update done or USB key not present	USB key inserted and software Update in progress (DON'T Remove the USB key)
7	LED USB1		Normal operation	Number of flashes show version at power up: See 10.1

8 Normal operation

Open Active

Closing Safety Active

Opening Safety Active

Stop Active

9 LIMIT SWITCHES

Motor 1 Open Position

Motor 1 Close Position

Motor 2 Open Position

Motor 2 Close Position

BOARD MALFUNCTION ERROR POSSIBLE CAUSES	SOLUTIONS
There were two consecutive obstacle detections (the audio alarm also should sound)	Remove obstructions
One of the motor driver components has failed	The board needs to be repaired
24V accessory power missing	The board needs to be repaired
The idle current in one of the motors is out of range	Check the motors
Both limit switches are active at the same time	Check the limit switches
Input voltage from the power supply is out of range	Check DC input voltage

The diagnostic LED shows only one error condition at a time, with the priority of the below table. In case there is more than one error once one is eliminated the LED will show the next

LED ERROR DISPLAY		
NUMBER OF FLASHES	ERROR CONDITION	SOLUTION
1	OBSTACLE DETECTION	Remove the obstacle, Check force and sensitivity settings
2	BOARD IN SLEEP MODE (Slow blinking means that the automatic open in case of power failure function is active)	Verify the presence of AC power
3	MOTOR 1 FAILURE	Inspect wiring to motor. If the wiring is good replace motor 1
4	MOTOR 2 FAILURE	Inspect wiring to motor. If the wiring is good replace motor 2
5	ENCODER on motor 1 or motor 2 error	<ul style="list-style-type: none"> Verify the encoder wiring and LED status. If they are correct replace the encoder Verify motor and encoder wire gauge are correct Verify operator is not on manual and hydraulic units don't need to be bled
6	FAIL SAFE FAILED	Verify the photocells wiring and alignment
7	BOARD THERMAL PROTECTION ACTIVE	Turn off the board and wait until the components cool down
8	MAX RUN TIME REACHED WITHOUT FINDING THE POSITIVE STOP (10 min.)	<ul style="list-style-type: none"> - Verify that the operator manual release is not engaged - Verify that the board recognizes the mechanical stop, in case redo the setup procedure - Verify that the gates slow down before reaching the positive stops. If they don't then redo the setup procedure

6. TIME LEARNING (SET-UP)

After powering up the board for the first time or when the board will need it the setup LED will blink at a slow frequency to indicate that the setup procedure to learn the running times is needed.

The setup can be redone at any time by pressing and holding the setup button as indicated below. The setup cannot be done until the safeties and stop inputs are wired.

After the setup first movement, if the leaves are opening instead of closing you need to reverse the wires going to the motor that moves in the wrong direction

AUTOMATIC TIME LEARNING

WARNING: If the time learning setup is done automatically then the slow down points are set by the board on his own

Move the leaves to the mid position Very important for a good result

- Press and hold the SETUP button until the SETUP LED lights up, wait about 3 sec. until it turns off and then release it immediately. NOTE: If you wait too long to release it the manual set-up will start. The LED will blink during the setup procedure
- Leaf 2 (if present) starts to move slowly in closing direction, stopping when it reaches the mechanical stop or FCC2.
- Leaf 1 begins to move slowly in closing direction, stopping when it reaches the mechanical stop, or FCC1.
- Leaf 1 starts to move slowly in opening direction, followed by leaf 2 (if present) still slowly.
- When they both reach the open mechanical stop or FCA1 and FCA2 they stop and reverse, leaf 2 (if present) automatically starts closing at full speed followed by leaf 1.
- When they reach the close mechanical stop or FCC1 and

FCC2 both leaves stop and leaf 1 restarts automatically opening at full speed followed by leaf 2 (if present).

- If you selected an automatic logic the board will wait for the pause time and then closes the gate automatically. Otherwise you have to give an OPEN command to close the gate.

WARNING: If the manual time learning setup is done then the slow down points must be set by the installer during the procedure. **Slow down is required for proper operation.**

Move the leaves to the mid position Very important for a good result

- Press and hold the SETUP button until the SETUP LED lights up, keep it pressed for about 3 sec. until it turns off and keep it pressed more until the leaf 2 (if present) starts moving slowly. The LED will blink during the setup procedure
- Leaf 2 will move in closing direction until it reaches the mechanical stop or FCC2
- Leaf 1 starts moving slowly until it reaches the mechanical stop or FCC1
- Leaf 1 starts moving in opening direction at the set speed (trimmer speed).
- At the point where you want the slowdown to start give an OPEN A command with the push button or the remote that is already stored in memory. Leaf 1 starts to slow down and stops when it reaches the mechanical stop or FCA1.
- Leaf 2 starts moving in opening direction at the set speed (trimmer speed)

7. At the point where you want the slowdown to start give an OPEN A command with the push button or the remote that is already stored in memory. Leaf 2 starts to slow down and stops when it reaches the mechanical stop or FCA2.
8. Leaf 2 starts to close at the set speed (trimmer speed).
9. At the point where you want the slowdown to start give an OPEN A command with the push button or the remote that is already stored in memory. The leaf 2 starts to slow down and stops when it reaches the mechanical stop or FCC2.
10. Leaf 1 starts to close at the set speed (trimmer speed).
11. At the point where you want the slowdown to start give an OPEN A command with the push button or the remote that is already stored in memory. Leaf 1 starts to slow down and stops when it reaches the mechanical stop or FCC1.
12. The manual time learning procedure is complete.

After time learning test the gate to set the force, speed and sensitivity using the trimmers.

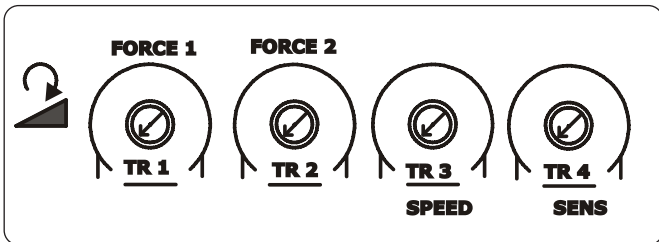

1. Apply resistance to the gate and adjust the Force to make sure that the operator creates enough thrust to reliably move the leaf.
2. Set the desired speed. Keep the speed relatively low on big and heavier gates.
3. After Force and Speed are set to the desired settings adjust the Sensitivity so the gate reverses promptly after hitting a rigid object.
4. After all the adjustments are done perform setup again.

7. OBSTACLE DETECTION

The obstacle detection function is achieved by controlling the current absorption and / or through the encoder connected to the motors.

If the gate encounters an obstacle during the movement of opening or closing, the obstacle detection function is activated and the operator reverses the direction of the gate.

In case of a second consecutive obstacle the operator stops the gate right away and any further command is inhibited. To re-enable the automation, you must remove power (and disconnect batteries if present) or open the STOP contact input. The Audio Alarm output will be active until this "reset".

This is a more detailed description of what happens after an obstacle detection:

Gate opening, obstacle detected:

The gate reverses partially (for 3 sec.) and STOPS. After that the gate is in a halfway position or completely closed.

If an open_A command is received, the gate tries to open from the current position:

- If there is another obstacle detection: the gate stops completely, the alarm goes off
- If the gate reaches the open position: the obstructions count is reset, the gate returns to normal operations

Gate closing, obstacle detected:

The gate reverses partially (for 3 sec.) and STOPS. After that the gate is in a halfway position or completely open.

If an open_A command is received in NON Automatic mode

- if the gate was not completely open: execute an open
- if the gate was completely open: execute a close

If an open_A command is received in Automatic mode:

- if the gate was not completely open: execute an open, wait for the pause time and then closes.
- if the gate was completely open: reload the pausetime, and then closes

If there is another obstacle detection: the gate stops completely, the alarm goes off.

If the gate reaches the close position: the obstructions count is reset, the gate returns to normal operations

8. ENCLOSURE

The E024U board is supplied on a panel that fits in a metal enclosure of this size:

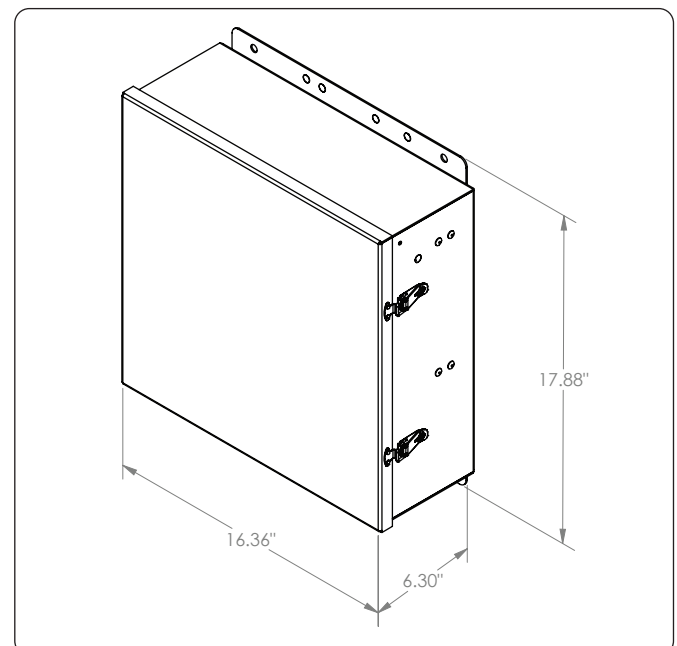

On the back panel there are: the control board, the power supply and additional accessories.

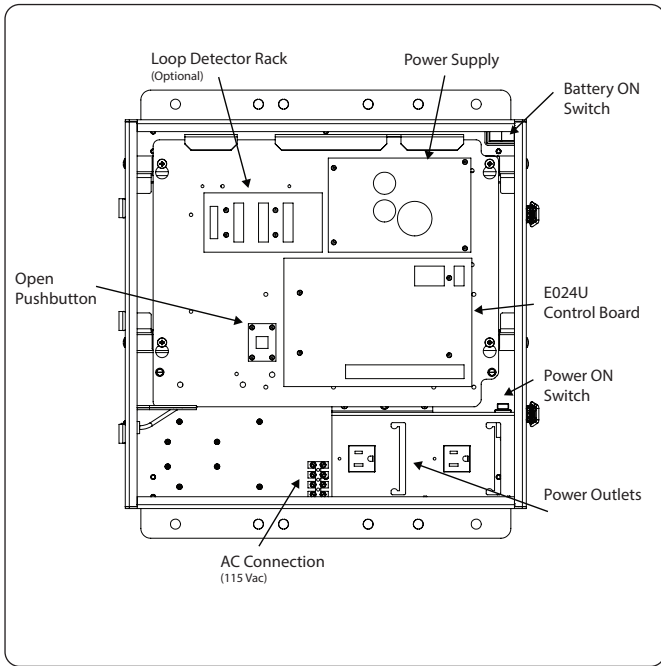

AC POWER CONNECTION

To connect AC power to the controller:

1. Turn the circuit breaker for the AC gate operator power OFF before connecting the AC input wires.
2. Turn OFF the Power Switch located on the right side of enclosure before connecting the AC input wires.
3. Connect the AC input wires to the AC terminal located on the bottom of the control box. See diagram below.
4. Batteries must be connected after the AC power is on. See Battery Power Connection.

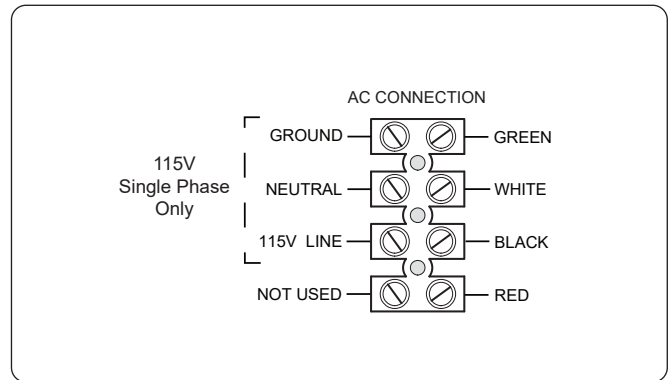

9. POWER CONNECTION

AC POWER GUIDELINES:

THE E024U control board and power supply uses a single phase AC power line to operate, charge the batteries, and power gate accessories. Use the following guidelines when installing the AC power:

1. Check the local wiring codes in all cases and follow all local building codes. Wiring and hookup should be performed by a qualified electrician/installer only.
2. AC power should be supplied from a circuit breaker panel and must have its own dedicated circuit breaker. This supply must include a green ground conductor.
3. Use copper conductor wires with liquid tight flexible conduit UL listed for electric cable protection
4. Properly ground the gate operator to minimize or prevent damage from power surges and/or lightning. Use a grounding rod if necessary. A surge suppressor is recommended for additional protection.

POWER SUPPLY

The E024U board is powered by a high efficiency switching power supply that takes 115VAC input and provides 36VDC to power the board. On the power supply board there is only one replaceable fuse: **6.3A timed**

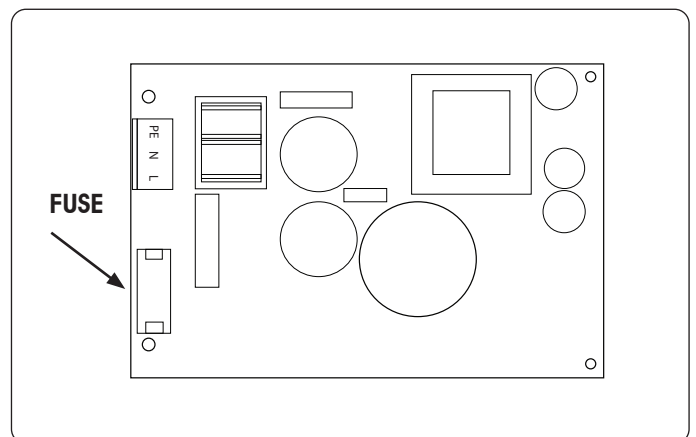

10. BACKUP BATTERY

The E024U board allows the connection of a 24V backup battery to provide power to operate the gate during blackouts. For more details about how the boards handles the loss of main power and how to configure its behaviour please see par 4.3 and DS1 switch 7.

Two 12V Batteries are located underneath the backplate with the Control Board and Accessories and come prewired from the factory

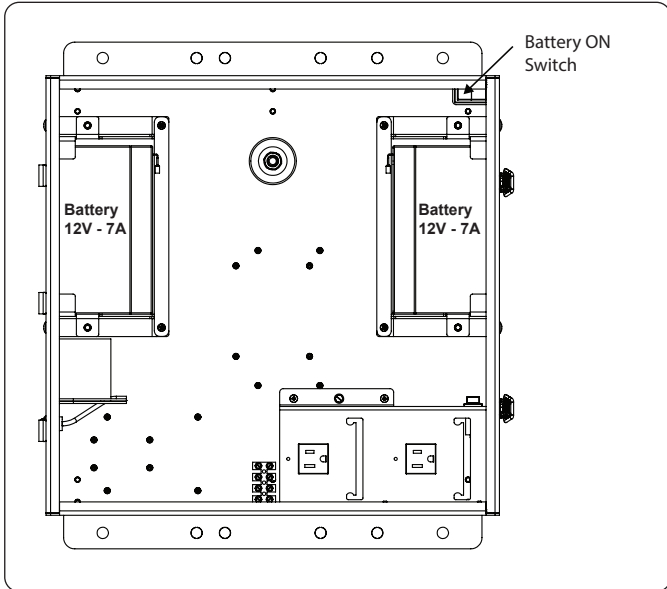

To enable the Battery Backup connect the Battery cable to the "BATTERY" connector on the control board

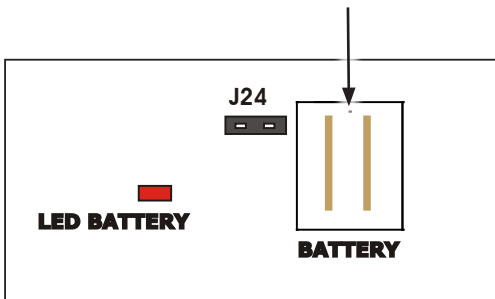

Then turn ON the Battery switch on the top right of the enclosure

DISABLE THE BATTERY CHARGER

The internal battery charger must be disabled to use an external charger. To disable the battery charger unplug jumper J24

J24 PRESENT = BATTERY CHARGING ACTIVE

J24 NOT PRESENT = BATTERY CHARGING NOT ACTIVE

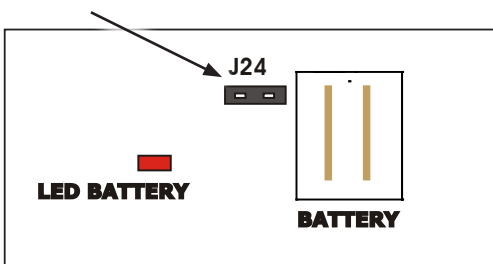

11. FIRMWARE UPGRADE

The E024U board keeps the operating firmware in a field programmable memory, it can be easily upgraded through the on board USB port

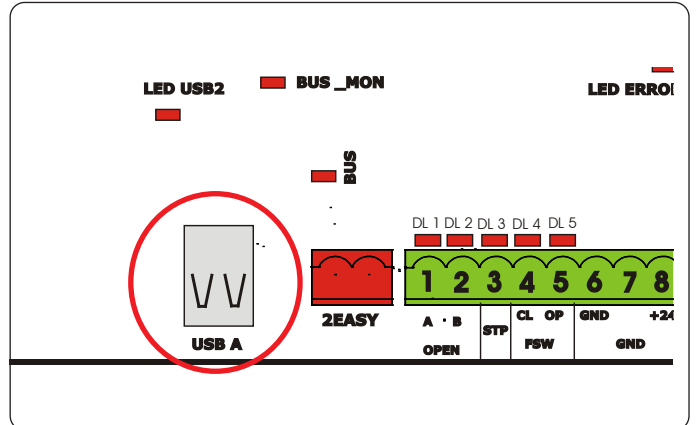

For the upgrade you need a USB Flash Drive, where you have to copy the file supplied by FAAC. Then follow these steps:

1. Disconnect the batteries if they are present.
2. Turn the AC power off and insert the Flash Drive into the USB A input on the board
3. Turn the AC power back on. The USB2 LED will start to flash to confirm the beginning of the software update. (WARNING: DON'T TURN THE POWER OFF OR REMOVE THE FLASH DRIVE UNTIL THE USB2 LED TURNS OFF.
4. Wait until the USB 2 LED turns off
5. Remove the USB Flash drive.
6. Cycle power, reconnect the batteries if needed and execute a new SETUP procedure (See chapter 6)



WARNING: Only upgrade the firmware with the proper file supplied by FAAC, otherwise the board could be damaged

VERIFY THE FIRMWARE VERSION

On initial power up watch the LED USB 1 on the bottom left of the board. The number of flashes indicate the version:

- | | |
|------------|---------|
| No Flashes | Ver. 1C |
| 1 Flash | Ver. 1D |
| 2 Flashes | Ver. 1E |
| 5 Flashes | Ver. 1G |

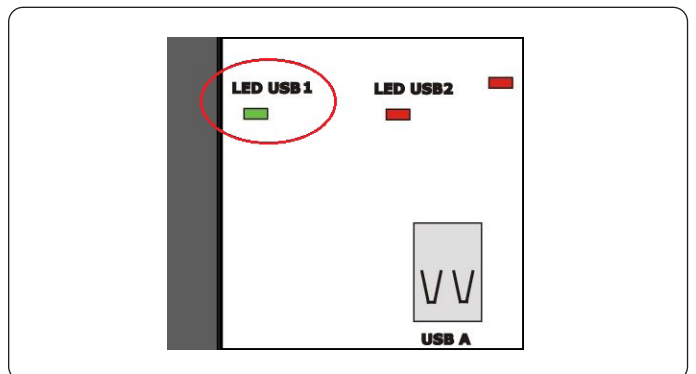

12. FUNCTION LOGICS

LOGIC "E"	PULSES					
SYSTEM STATUS	OPEN A	OPEN B	STOP	FSW OP	FSW CL	FSW CL/OP
CLOSED	opens the leaves	opens leaf 1	no effect (OPEN disabled)	no effect (OPEN disabled)	no effect	no effect (OPEN disabled)
OPENING	stops operation (1)	stops operation	stops operation	immediately reverses at closing	no effect	stops and opens at release (OPEN stops - saves CLOSE)
OPEN	recloses leaves immediately (1)	recloses leaves immediately	no effect (OPEN/CLOSE disabled)	no effect	no effect (CLOSE disabled)	no effect (OPEN/CLOSE disabled)
CLOSING	reopens leaves immediately	reopens leaves immediately	stops operation	no effect	reverses at opening	stops and opens at release (OPEN stops - saves CLOSE)
BLOCKED	closes leaves	closes leaves	no effect (OPEN/CLOSE disabled)	no effect (OPEN disabled)	no effect (CLOSE disabled)	no effect (OPEN stops - saves CLOSE)

(1) if the cycle began with OPEN-B (leaf 1), both leaves are activated at opening

LOGIC "A"	PULSES					
SYSTEM STATUS	OPEN A	OPEN B	STOP	FSW OP	FSW CL	FSW CL/OP
CLOSED	opens and closes after pause time	opens leaf 1 and closes after pause time	no effect (OPEN disabled)	no effect (OPEN disabled)	no effect	no effect (OPEN disabled)
OPENING	no effect (1)	no effect	stops operation	reverses at closing	no effect	stops and opens at release (saves CLOSE)
OPEN IN PAUSE	reloads pause time (1)	reloads pause time of released leaf	stops operation	no effect	recharges pause time (CLOSE disabled)	recharges pause time (CLOSE disabled)
CLOSING	reopens leaves immediately	reopens leaves immediately	stops operation	no effect	reverses at opening	stops and opens at release (saves CLOSE)
BLOCKED	closes leaves	closes leaves	no effect (OPEN/CLOSE disabled)	no effect (OPEN disabled)	no effect (CLOSE disabled)	no effect (OPEN/CLOSE disabled)

(1) if the cycle began with OPEN-B (leaf 1), both leaves are activated at opening

LOGIC "S"	PULSES					
SYSTEM STATUS	OPEN A	OPEN B	STOP	FSW OP	FSW CL	FSW CL/OP
CLOSED	opens and closes after pause time	opens released leaf and closes after pause time	no effect (OPEN disabled)	no effect (OPEN disabled)	no effect	no effect (OPEN disabled)
OPENING	no effect (1)	no effect	stops operation	reverses at closure	continues to open and recloses immediately	stops and opens at release (saves CLOSE)
OPEN IN PAUSE	recloses leaves immediately (1)	recloses leaves immediately	stops operation	no effect	stops and, at release, closes	stops and, at release, closes
CLOSING	reopens leaves immediately	reopens leaves immediately	stops operation	no effect	reverses at opening (see DS1-SW8) and closes immediately at end	stops and opens after release and closes immediately at end
BLOCKED	closes leaves	closes leaves	no effect (OPEN/CLOSE disabled)	no effect (OPEN disabled)	no effect (CLOSE disabled)	no effect (OPEN/CLOSE disabled)

(1) if the cycle began with OPEN-B (leaf 1), both leaves are activated at opening

LOGIC "EP"	(1) if the cycle began with OPEN-B (leaf 1), both leaves are activated at opening					
SYSTEM STATUS	OPEN A	OPEN B	STOP	FSW OP	FSW CL	FSW CL/OP
CLOSED	opens the leaves	opens leaf 1	no effect (OPEN disabled)	no effect (OPEN disabled)	no effect	no effect (OPEN disabled)
OPENING	stops operation (1)	stops operation	stops operation	immediately reverses at closure	no effect	stops and opens at release (OPEN stops - saves CLOSE)
OPEN	recloses leaves immediately (1)	recloses leaves immediately	no effect (OPEN/CLOSE disabled)	no effect	no effect (CLOSE disabled)	no effect (OPEN/CLOSE disabled)
CLOSING	stops operation	stops operation	stops operation	no effect	reverses at opening	stops and opens at release (OPEN stops - saves CLOSE)
BLOCKED	restarts moving in opposite direction. Always closes after STOP	restarts moving in opposite direction. Always closes after STOP	no effect (OPEN/CLOSE disabled)	no effect (OPEN disabled)	no effect (CLOSE disabled)	no effect (OPEN stops - saves CLOSE)

LOGIC "AP"	PULSES					
SYSTEM STATUS	OPEN A	OPEN B	STOP	FSW OP	FSW CL	FSW CL/OP
CLOSED	opens and closes after pause time	opens leaf 1 and closes after pause time	no effect (OPEN disabled)	no effect (OPEN disabled)	no effect	no effect (OPEN disabled)
OPENING	stops operation (1)	stops operation	stops operation	reverses at closing (saves OPEN)	no effect	stops and opens at release (OPEN stops - saves CLOSE)
OPEN IN PAUSE	stops operation (1)	stops operation	stops operation	no effect	recharges pause time (CLOSE disabled)	recharges pause time (CLOSE disabled)
CLOSING	reopens leaves immediately	reopens leaves immediately	stops operation	no effect	reverses at opening (see DS1-SW8)	stops and opens at release (OPEN stops - saves CLOSE)
BLOCKED	closes leaves	closes leaves	no effect (OPEN/CLOSE disabled)	no effect (OPEN disabled)	no effect (CLOSE disabled)	no effect (OPEN/CLOSE disabled)

(1) if the cycle began with OPEN-B (leaf 1), both leaves are activated at opening

LOGIC "SP"	PULSES					
SYSTEM STATUS	OPEN A	OPEN B	STOP	FSW OP	FSW CL	FSW CL/OP
CLOSED	opens and closes after pause time	opens leaf 1 and closes after pause time	no effect (OPEN disabled)	no effect (OPEN disabled)	no effect	no effect (OPEN disabled)
OPENING	stops operation (1)	stops operation	stops operation	reverses at closure	continues to open and recloses immediately	stops and opens after release and closes immediately at end (OPEN stops - saves CLOSE)
OPEN IN PAUSE	recloses leaves immediately (1)	recloses leaves immediately	stops operation	no effect	stops and, at release, closes	stops and, at release, closes
CLOSING	stops operation	stops operation	stops operation	no effect	reverses at opening	stops and opens at release (saves CLOSE)
BLOCKED	restarts moving in opposite direction. Always closes after STOP	restarts moving in opposite direction. Always closes after STOP	no effect (OPEN/CLOSE disabled)	no effect (OPEN disabled)	no effect (CLOSE disabled)	no effect (OPEN/CLOSE disabled)

(1) if the cycle began with OPEN-B (leaf 1), both leaves are activated at opening

LOGIC "B"	PULSES					
SYSTEM STATUS	OPEN A	OPEN B	STOP	FSW OP	FSW CL	FSW CL/OP
CLOSED	opens the leaves	no effect	no effect (OPEN disabled)	no effect (OPEN disabled)	no effect	no effect (OPEN disabled)
OPENING	no effect	closes leaves	stops operation	reverses at closure	no effect	stops and, at release, closes (saves OPEN/CLOSE)
OPEN	no effect	closes leaves	no effect (OPEN/CLOSE disabled)	no effect	no effect (CLOSE disabled)	no effect (OPEN/CLOSE disabled)
CLOSING	opens the leaves	no effect	stops operation	no effect	reverses at opening	stops and opens at release (saves OPEN/CLOSE)
BLOCKED	opens the leaves	closes leaves	no effect (OPEN/CLOSE disabled)	no effect (OPEN disabled)	no effect (CLOSE disabled)	no effect (OPEN/CLOSE disabled)

LOGIC "C"	CONTINUOUS COMMANDS		PULSES			
SYSTEM STATUS	OPEN A	OPEN B	STOP	FSW OP	FSW CL	FSW CL/OP
CLOSED	opens the leaves	no effect	no effect (OPEN disabled)	no effect (OPEN disabled)	no effect	no effect (OPEN disabled)
OPENING	no effect	closes leaves	stops operation	reverses at closure	no effect	stops and, at release, closes (saves OPEN/CLOSE)
OPEN	no effect	closes leaves	no effect (OPEN/CLOSE disabled)	no effect	no effect (CLOSE disabled)	no effect (OPEN/CLOSE disabled)
CLOSING	opens the leaves	no effect	stops operation	no effect	reverses at opening	stops and opens at release (saves OPEN/CLOSE)
BLOCKED	opens the leaves	closes leaves	no effect (OPEN/CLOSE disabled)	no effect (OPEN disabled)	no effect (CLOSE disabled)	no effect (OPEN/CLOSE disabled)

13. ACCESSORIES

SHADOW LOOP INTERFACE (p/n 790062)

Through the use of the XIB interface board you can connect an additional loop detector (center or shadow) to the E024U board to keep the gate open if vehicles are obstructing the closing path. With a dip switch setting the shadow loop can function on both opening and closing (see section 4.3)

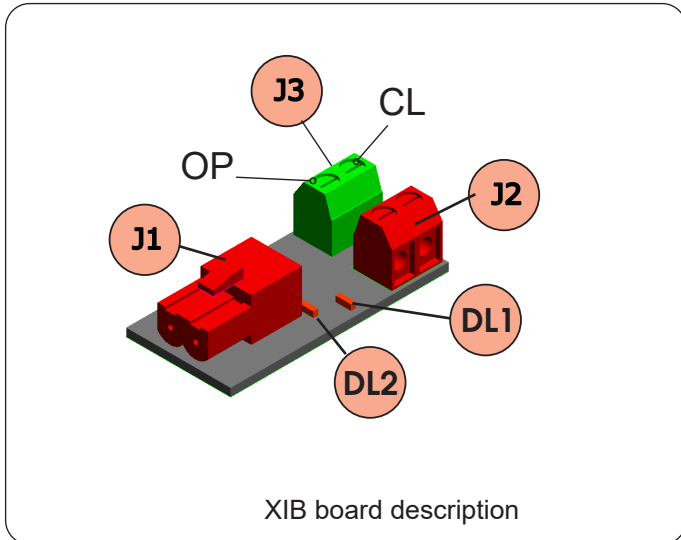

J1 (RED)	Connects to "2easy" BUS input on the E024U
J2 (RED)	Terminal for the connection of the encoder
J3 CL (GREEN)	Terminal for the NC connection of the shadow loop detector
J3 OP (GREEN)	Terminal for the NC connection of second open safety
DL1	LED for diagnostics of devices connected to the J3 OP
DL2	LED for diagnostics of devices connected to the J3 CL

INSTALLING THE INTERFACE

1. Turn power OFF
2. Plug in the XIB interface to the 2EASY connector on the E024U board
3. Wire the shadow loop detector NC output to the CL input on the XIB board as in figure below
4. Connect Common from loop detector to GND (terminal 6) on E024U
5. If no second open safety device is present jump out the OP input on XIB board to GND (terminal 6) on the E024U
6. Wire the encoder (if needed) to J2
7. Refer to Fig. A11 for the wiring schematic
8. Turn power back ON
9. Press and release the SW1 button quickly. The board will recognize that the XIB board has been removed
10. Re-program run time if needed.

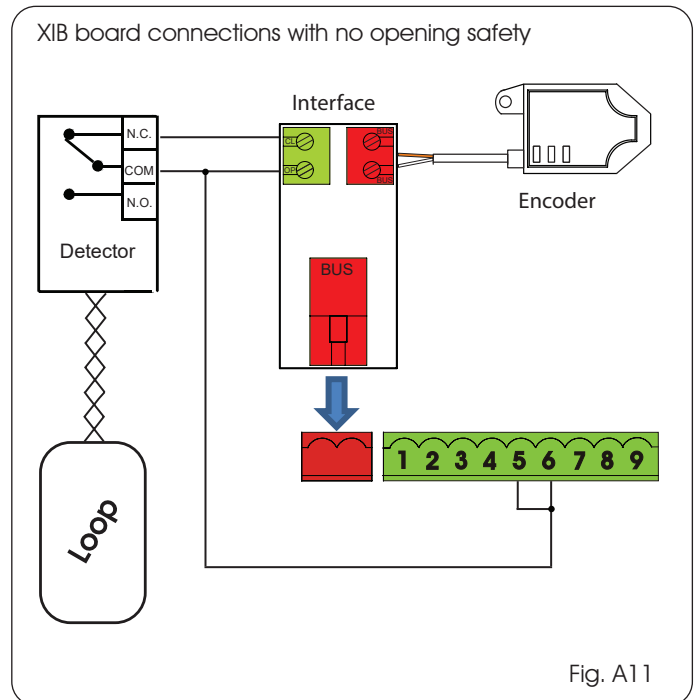

REMOVING THE INTERFACE

1. Turn power OFF
2. Unplug the board and remove the wiring
3. Move the encoder wires (if present) to the 2EASY connector on the board
4. Turn power back ON
5. Verify that leaf 1 & 2 lights on the encoder are correct
6. Press and release the SW1 button quickly. The board will recognize that the XIB board has been removed
7. Re-program run time if needed.

NOTE:

- Do not connect the shadow loop detector in series with regular closing safety devices.
- If the E024U board doesn't have the correct software installed the shadow loop will act as a normal closing safety, detecting also the gate itself and not allowing the closing movement to complete. Please contact technical support for assistance in that case.

SECOND OPEN SAFETY INPUT

The OP input on the XIB board can be used as a second monitored open safety input.

When open safety monitoring is turned ON on the E024U board (Dip SW 12 ON) the OP input on the XIB (J3 OP) is monitored and can be used to protect an entrapment zone. See Fig. A12a/b for the connections.

In case only one opening safety input is needed and the XIB board is present connect the opening safety photocell to FSW OP on the E024U and J3 OP on the XIB in parallel. See Fig. A13a/b for the connections.

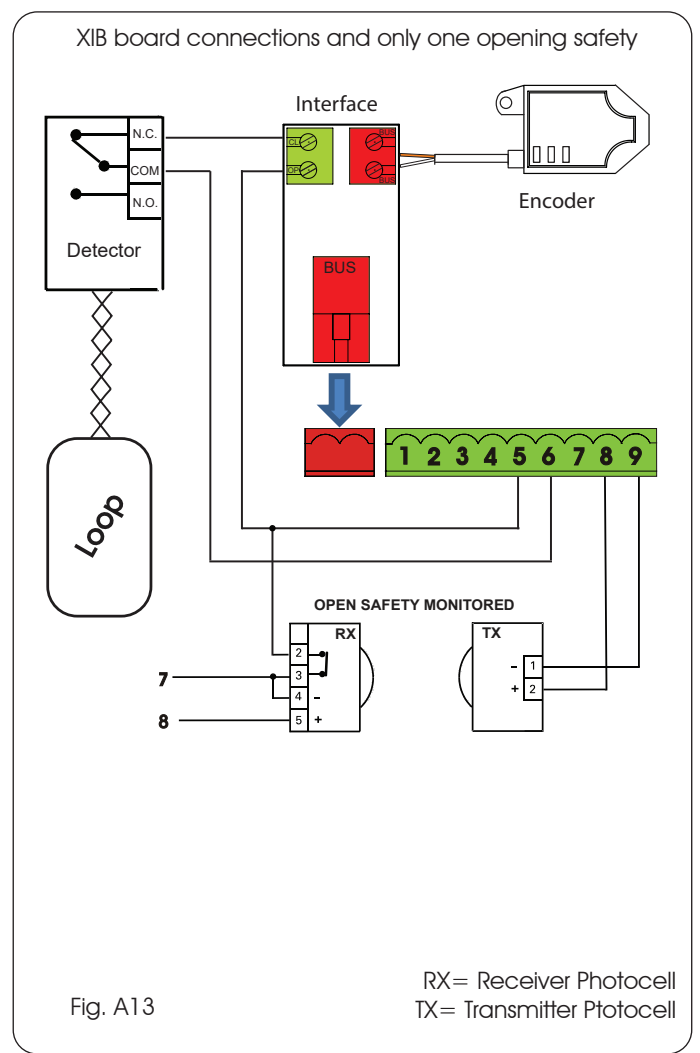
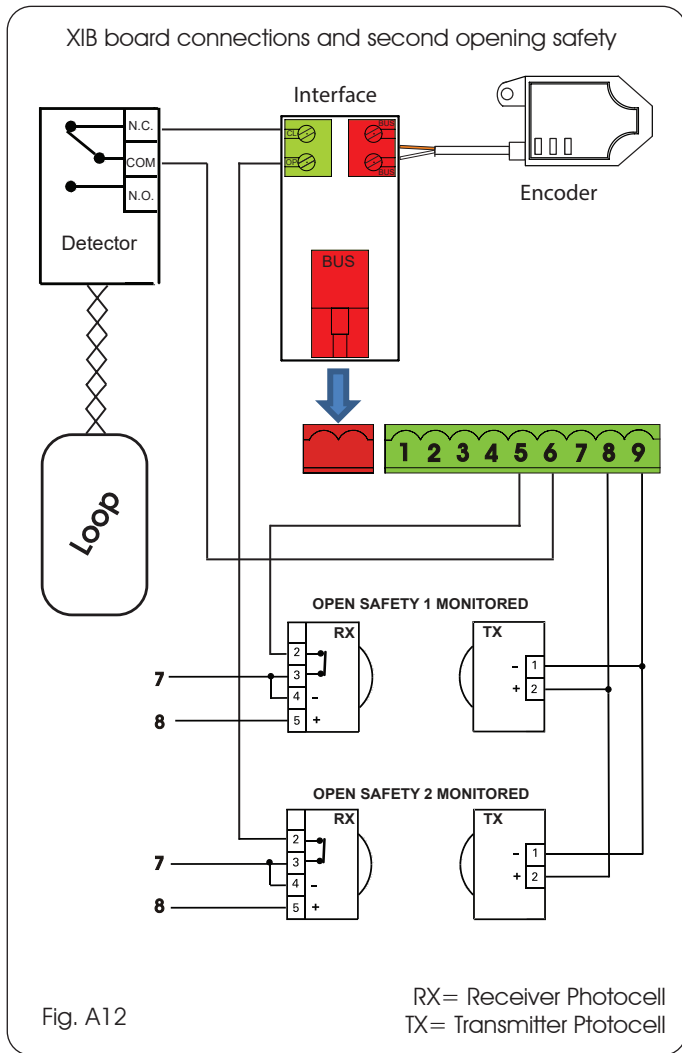

DIAGNOSTIC TABLE				
	OFF	SLOW FLASHING (FLASH EVERY 5 secs.)	ON STEADY	FAST FLASHING (FLASH EVERY 0.5 sec)
DL1	"XIB" board malfunction or no power	J3 OP terminal open (missing jumper on the OP input)	J3 OP terminal closed (normal condition)	Error condition on the BUS
DL2	"XIB" board malfunction or no power	J3 CL terminal open (loop detector active or not connected)	J3 CL terminal closed (loop detector in idle condition)	

LOOP DETECTORS INTERFACE (p/n 2670.1)

The Loop Detector Interface allows connection of up to three plug-in detectors associated with standard functions. The board is designed to fit in the FAAC standard 16" x 14" enclosure on the existing DIN rail. To connect the interface board:

- 1) Connect the 2EASY BUS from the E024U to the interface board (no polarity) - Green Wires
- 2) Connect pin 8 on the E024U board (+24V) to the +24 input on the interface board - Red Wire
- 3) Connect pin 7 on the E024U board (GND) to the GND input on the interface board - Black Wire
- 4) Connect the loops to the interface board as in the figure below

Turn the power on on the E024U board. The LED on the interface board will blink briefly and then will stay ON solid if the BUS connection is working correctly.

IMPORTANT: Briefly press the SW1 button on the E024U board to make it aware of the presence of the additional interface board.

To make sure the board is working properly you can check the behaviour of BUS LED on the E024U board. It will be normally on when none of the loop detectors is active. If any of the detectors is activated the LED will turn off.

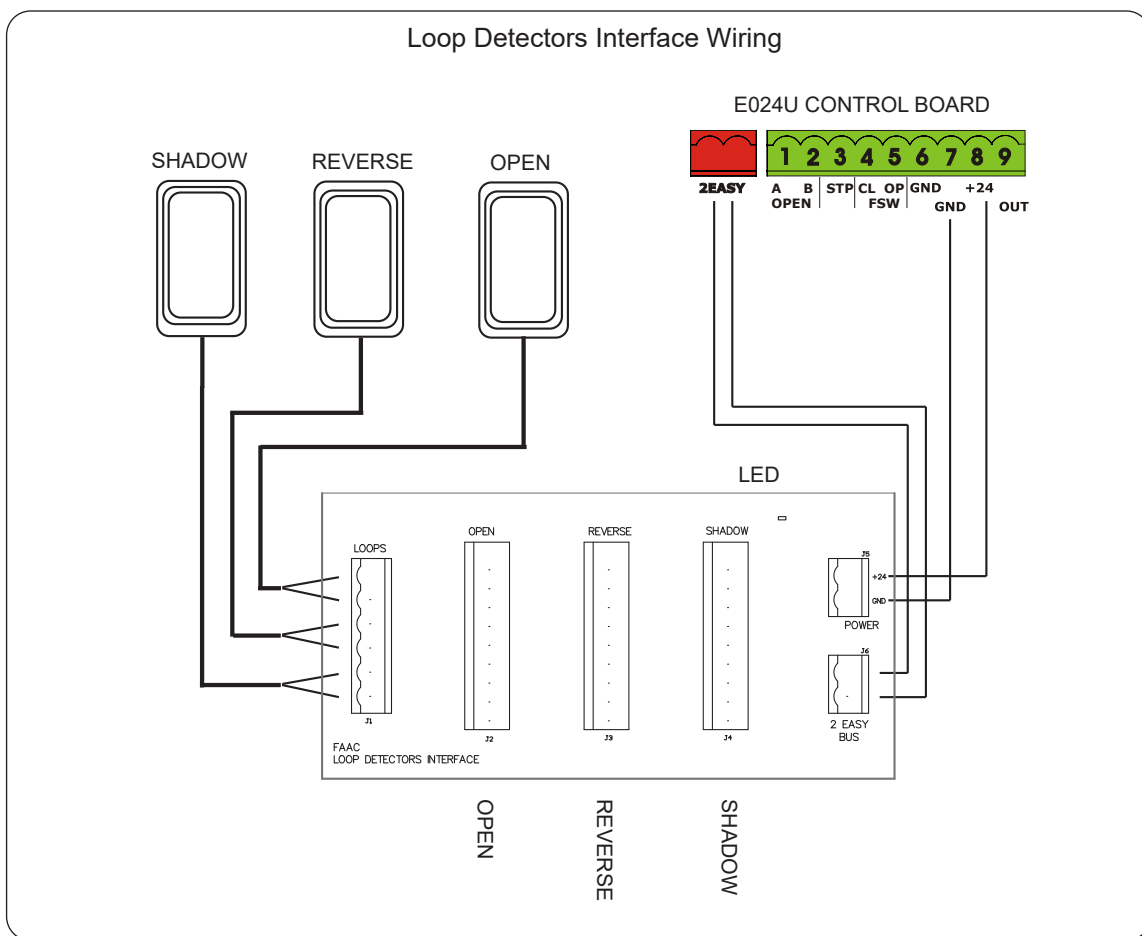

NOTE: You can use the shadow loop interface OR the loop detectors interface but not both at the same time. If two monitored open safeties are required the additional loop detectors (other than the shadow) must be wired directly to the E024U board.

SPARE PARTS DIAGRAMS

S450H CBAC

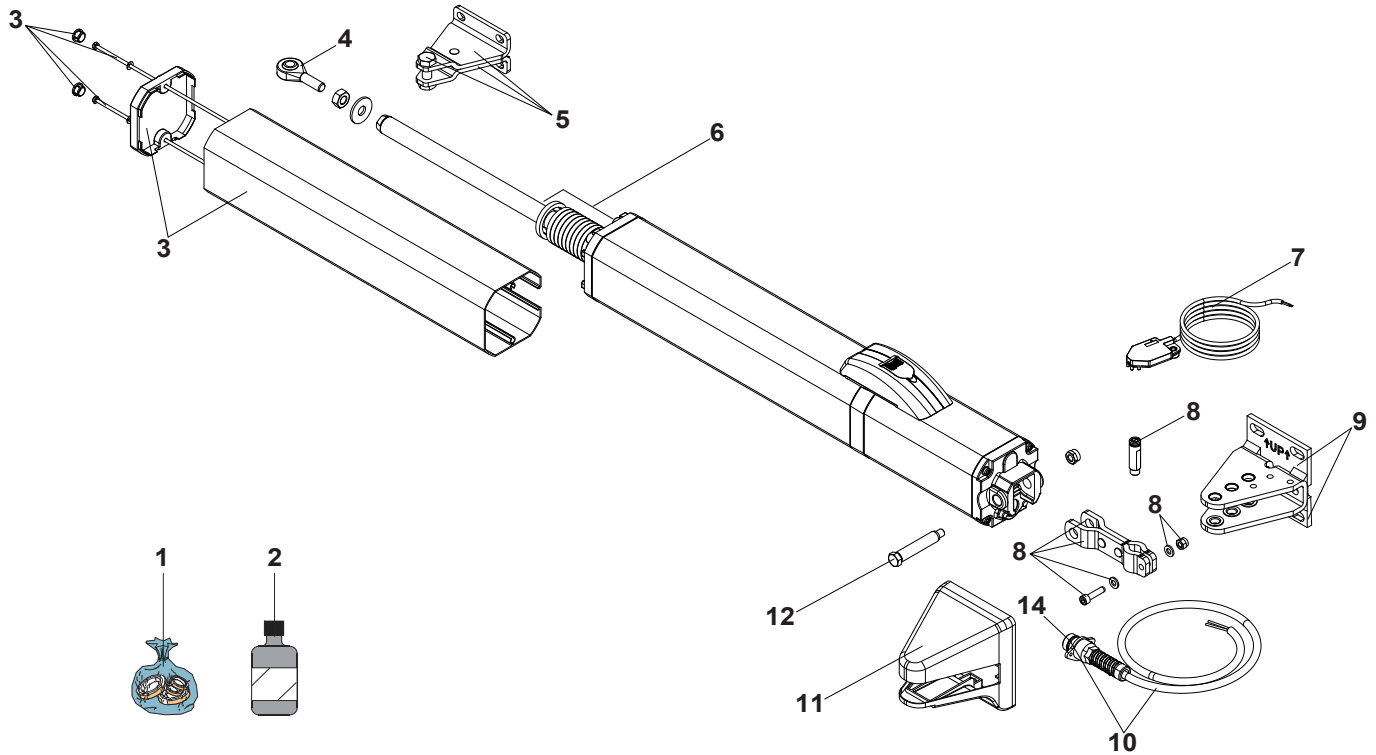

Part	Part Number	Description
1	2181.1	Seal Kit S450H
2	714019 QT.1	Oil 1 Quart Bottle FAAC HP
3	63003332	S450H Cover Group
4	7073035	Swivel Joint
5	63001945	S450H Front Bracket
6	63001975	Spacers Kit For S450H (Sold As Bag of 11)
7	63001875	S450H Encoder
8	63003334	S450H Rear Fork And Pin
9	63001915	Rear Bracket For S450H
10	63001935	S450H Moulded Cable Kit
11	63001925	S450H Rear Bracket Cover
12	7182175	Long Pin
14	7090290015	O-Ring 15.60 X 1.78 mm

S450H CBAC

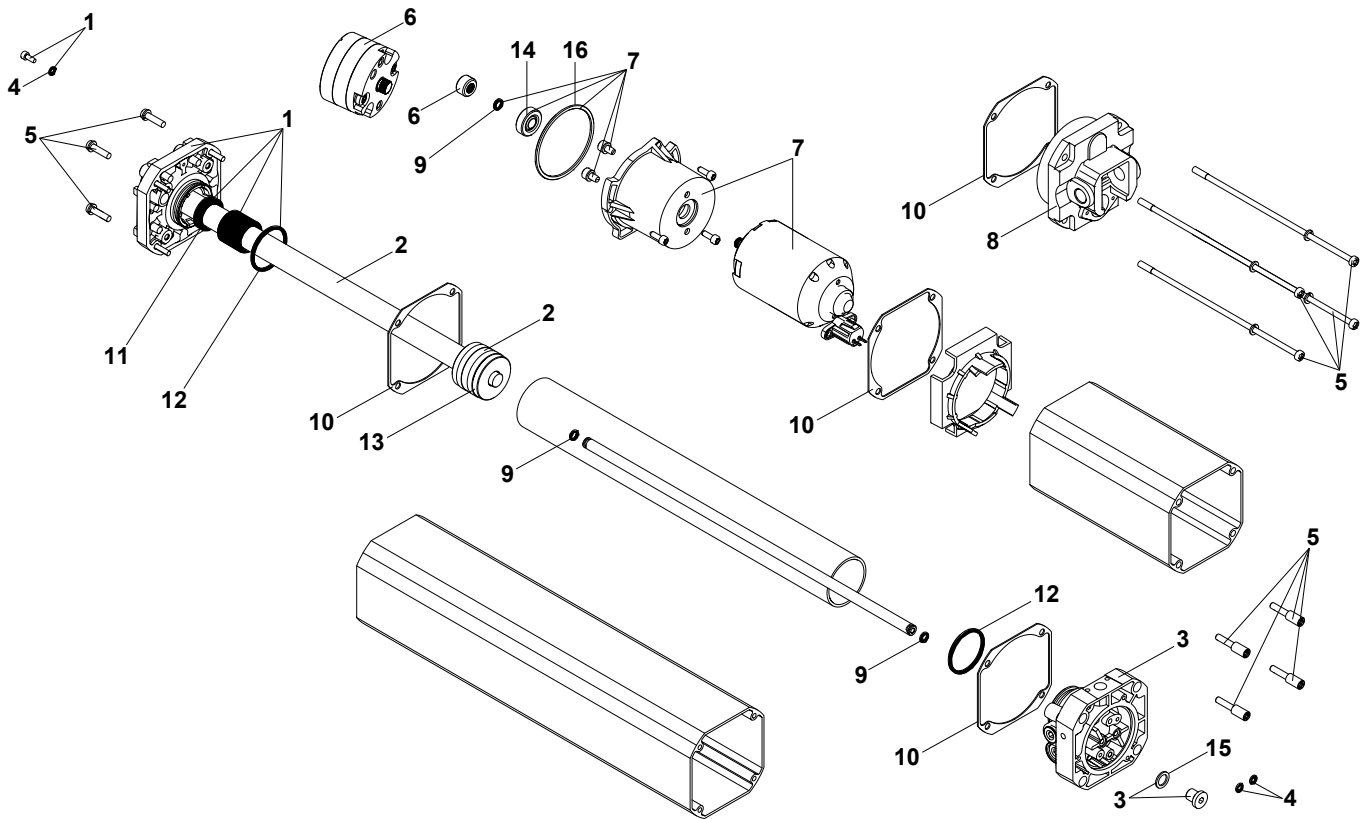

Part	Part Number	Description
1	63000716	S450H Front Flange
2	63000656	S450H Riveted Piston
3	63000676	S450H CBAC Valve Body
4	7090010015	O-Ring 4.48 x 1.78 mm
5	63003335	S450H Tie Rods and Tank Screws
6	63003333	Pump Assembly
7	63000636	S450H Motor Assembly
8	63000806	S450H Rear Flange
9	7090815	O-Ring Retract Tube
10	63000013	Gasket S450H
11	63000315	Front Flange Seal
12	7090350025	O-Ring 34.6 x 2.62 mm
13	7095035	Piston Rod Packing
14	63000306	Gasket
15	63000756	S450H Plug Seal (Bag of 10)
16	63003255	O-Ring (Bag of 5)

CBAC DISTRIBUTION FLANGE

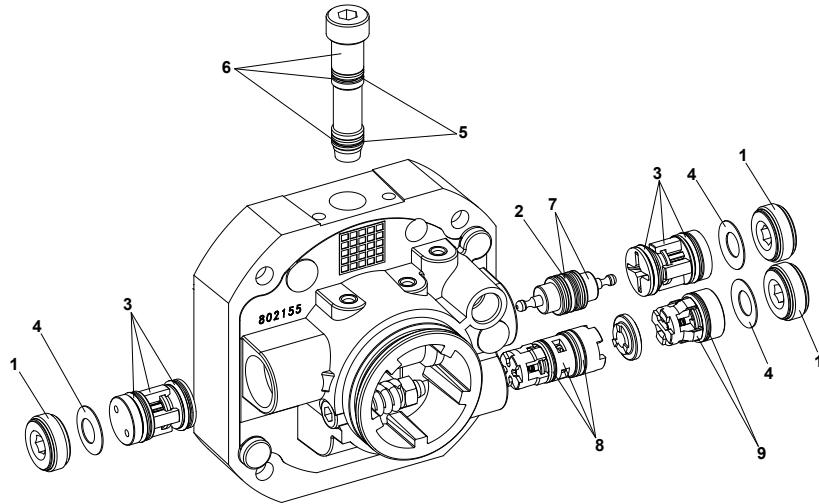

Part	Part Number	Description
1	63000816	Valve Ring Nut
2	7090300015	O-Ring 7.66 x 1.78 mm (20 pc pack)
3	4404085	Lock Valve
4	63000577	Washer Cup Spring (30 pc pack)
5	7090280015	O-Ring 5.28 X 1.78mm
6	63000826	Manual Release Valve
7	4180315	Shuttle Piston
8	4404095	Inlet Valve (Bi-Directional)
9	4404065	Inlet Valve

MANUAL RELEASE

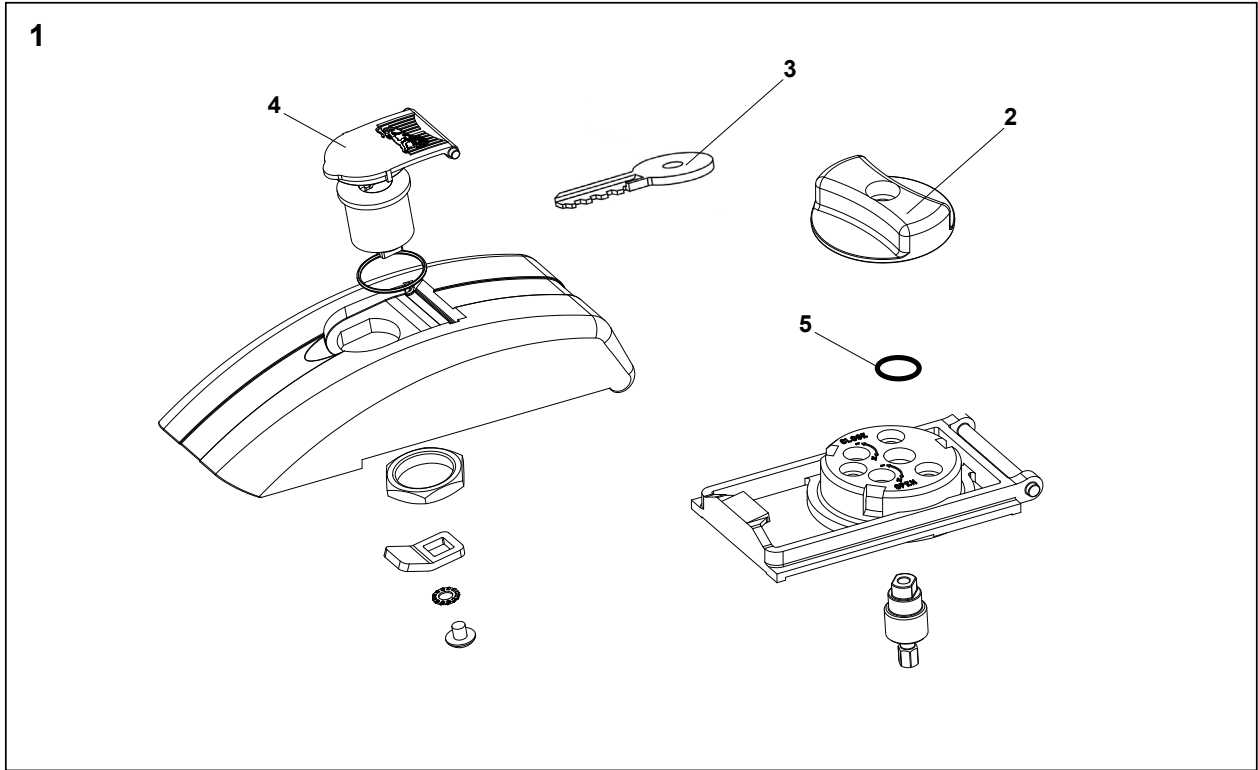

Part	Part Number	Description
1	63001985	Release Assembly S450H
2	7290445	Manual Release Knob w/ Screw
3	7131005	Viro Manual Release/Door Key
4	7275275	Keyhole Cover
5	7090150015	O-Ring 9.25 X 1.78 mm

LIMITED WARRANTY

FAAC International, Inc. ("Seller") warrants the first Purchaser of the product to be free from defects in material and workmanship for a specific period as defined by the Warranty disclosure on the website www.faacusa.com. The Warranty Period commences from the date of invoice.

Control Boards, Accessories or Spare Parts factory installed or sold with any of the products above carry the same warranty period as the product they are sold with, excluding batteries that carry a maximum 2 year warranty.

Products repaired under warranty carry the remainder of the original warranty period. For products repaired outside of warranty, the Seller warrants that all parts used for the repair will be free from defects in materials and workmanship for a period of ninety (90) days.

Defective products must be returned to Seller, freight prepaid by Purchaser, within the warranty period. A Return Material Authorization Number (RMA) must be obtained before product is returned. Items returned will be repaired or replaced, at Seller's option, upon an examination which discloses to the satisfaction of the Seller that the item is defective. The Seller will return the warranted item freight prepaid.

This limited Warranty covers the product under the normal use and service for which it was intended, provided it has been properly installed and operated. Seller's obligations under this warranty shall be limited to the repair or exchange of any part. This warranty shall not apply to products or parts thereof which have been repaired or altered, without Seller's written consent, outside of Seller's workshop or altered in any way so as, in the judgment of Seller, to affect adversely the stability or reliability of the product(s) or has been subject of misuse, negligence, or accident, or has not been operated in accordance with the product's instructions or has been operated under conditions more severe than, or otherwise exceeding, those set forth in the specifications for such product(s).

When the warranty service involves the exchange of an operator or part, the item the Seller replaces becomes its property and the replacement becomes Purchaser's property. The Purchaser represents that all removed items are genuine and unaltered. The replacement may not be new but will be in good working order and at least functionally equivalent to the item replaced. The replacement assumes the warranty service status of the replaced item.

The products are not warranted to meet the specific requirements, if any, of safety codes of any particular state, municipality, or other jurisdiction, and the Seller doesn't assume any risk or liability whatsoever resulting from the use thereof, whether used singly or in combination with other machines or apparatus.

The Seller does not assume nor authorizes any person to assume for them any other liability in connection with the sale or use of the products of beyond that extended herein.

The warranty hereinabove set forth shall not be deemed to cover maintenance parts, including, but not limited to hydraulic oil, motor brushes, or the like. No agreement to replace or repair shall constitute an admission by the Seller of any legal responsibility to effect such replacement to make such repair, or otherwise.

All products sold by the Seller are subject to design and/or appearance modifications, which are production standards at the time of shipment. The Seller may, but shall not be required to, modify or update products shipped prior to a current production standard.

THIS WARRANTY IS EXPRESSLY IN LIEU OF ALL OTHER WARRANTIES EXPRESSED OR IMPLIED INCLUDING THE WARRANTIES OF MERCHANTABILITY AND FITNESS FOR USE. THIS WARRANTY SHALL NOT APPLY TO PRODUCTS OR ANY PART THEREOF WHICH HAVE BEEN SUBJECT TO ACCIDENT, NEGLIGENCE, ALTERATION, ABUSE, OR MISUSE OR IF DAMAGE WAS DUE TO IMPROPER INSTALLATION OR USE OF IMPROPER POWER SOURCE, OR IF DAMAGE WAS CAUSED BY FIRE, FLOOD, LIGHTNING, ELECTRICAL POWER SURGE, EXPLOSION, WIND STORM, HAIL, AIRCRAFT OR VEHICLES, VANDALISM, RIOT OR CIVIL COMMOTION, OR ACTS OF GOD.

The Seller shall not be liable for any loss or damage whatsoever resulting, directly or indirectly, from the use or loss of use of the product(s). Without limiting the foregoing, this exclusion from liability embraces a Purchaser's expenses for downtime or for making up downtime, lost profit, damages for which the Purchaser may be liable to other persons, damage to property, and injury to or death of any persons.

This limited warranty extends only to wholesale customers who buy directly through the Seller's normal distribution channels. The Seller does not warrant its products to end consumers. Consumers must inquire from their selling dealer as to the nature and extent of that dealer's warranty, if any.

THE LIMITED WARRANTY OFFERED HEREIN IS THE SOLE AND EXCLUSIVE REMEDY AVAILABLE TO THE PURCHASER. CORRECTION OF DEFECTS, IN THE MANNER AND FOR THE PERIOD OF TIME DESCRIBED HEREIN, SHALL CONSTITUTE THE COMPLETE FULFILLMENT OF ALL LIABILITIES OF SELLER TO THE PURCHASER WITH RESPECT TO THE COVERED PRODUCT, AND SHALL CONSTITUTE FULL SATISFACTION OF ALL CLAIMS, WHETHER BASED ON CONTRACT, NEGLIGENCE, STRICT LIABILITY OR OTHERWISE. IN NO EVENT SHALL SELLER BE LIABLE FOR ANY LOSS OF PROFITS OR ANY INDIRECT, CONSEQUENTIAL, INCIDENTAL, SPECIAL OR PUNITIVE DAMAGES ARISING OUT OF SELLER'S BREACH OF THIS LIMITED WARRANTY, OR ARISING OUT OF THE CUSTOMER'S INABILITY TO USE THE COVERED PRODUCT, EVEN IF SELLER HAS BEEN ADVISED OF THE POSSIBILITY OF SUCH DAMAGES.

Some states do not allow the exclusion or limitation of incidental or consequential damages, so the above limitation may not apply to a particular Purchaser. This Limited Warranty gives the Purchaser specific legal rights. The Purchaser may also have other rights, which vary from state to state.

