

Installation & User Instructions



Praetorian Guard IP Intercom
(with 4G access Point)



PROFESSIONAL INSTALL ONLY



Manual to work from v57 Firmware

Tip: Site Survey BEFORE you begin.
See page 4



WARNING

Do not power from the gate controller. Only use the provided UL power supply, otherwise damage may occur and warranty may be void.

Index

Section	Pages
PHASE 1 – SITE SURVEY	3-4
Site Survey (4G Router)	4
PHASE 2 – PRODUCT OVERVIEW	5-24
Overview of Call Points	6-9
Overview of Optional Extra Devices	10
More Detail....	11-17
PCB Module Overview	18-19
Component Sellable Codes	20
Technical Specifications	21-24
PHASE 3 – SETUP 4G	25-46
PHASE 3a – SETUP 4G (Router Separate)	26-30
PHASE 3b – SETUP 4G (Router Integrated)	31-36
PHASE 3 – SETUP 4G (Continued)	37-46
4G Setup Intercom on App	38-42
Time Sync & Testing	43-44
Answering on Android	45
Answering on iOS (Apple)	46
PHASE 4 - INSTALLATION	47-56
How to Achieve & Maintain IP55 Rating	48
Power & Antenna	49
Solar Power	50
Battery Backup Option	51
Wiring Example	52
Connecting Slave Devices	53
Adding Additional APP Users	54
Sound, Volumes and Speech / Intercom & Device Sound	55
Options	
Using Keypad Codes	56
PHASE 5 – ADVANCED SETUP	57-72
Feature Shortcuts & Settings Overview	58
Standard Features	59
Edit Intercom Details / Add a New Device ID	60
Ringtones of In-app Call / Check APP version	61
Check Intercom Firmware / Add, Edit or Delete Users & Logins	62
Adjust Relay Trigger Times / Adjust Intercom Time	63
Wi-Fi Settings / Adjust Maximum Monitoring Time	64
Adjust Maximum Talking Time / Adjust Maximum Calling Time	65
Reboot Intercom / Simplex / Duplex Audio Selection	66
Advanced Feature Overview / Notifications	67
Auto Relay Times / Camera Stream Resolution	68
Activity Log / Auto Reboot	69
Keypad Codes	70
PROX Cards/Tag IDs	71
Voicemail Option for missed Callers / Motion Detection Option	72
Troubleshooting	73-74
App Updates / Firmware Updates / Extra Resources	75
Feedback	76
Intercom Maintenance / Environmental Information / Ingress	77
Warranty	78
Free Extra Year Warranty	79
Regulatory Compliance / Declaration of Conformity	80

PHASE 1

Site Survey

Site Survey (4G Router)



YES!

I have 4G signal at the gate with my phone! If not, STOP. You will need some! Try a different network provider.



Upload Speed

I have at least 1.5 Mb UPLOAD speed. If not STOP! This system may operate intermittently remotely or have delayed PUSH notifications.

Note: When using our 4G access point the upload speed will be influenced by the GSM signal being received. With a high signal level the access point can pull approx. 10mbps upload.

The Praetorian Guard is specially designed to transmit the video and audio stream using on average 400 KBit/sec (peaking to 1Mbps). This loosely translates to requiring a minimum of 1.5mbps UPLOAD speed on the network that the intercom is connected to. The higher the upload speed the better quality of image up to approx. 4mbps.

If you have a good GSM signal for the network being used you can expect to have an upload speed of up to 10mbps.

PHASE 2

Product Overview

More Detail....

Architectural Model (4G Router Separate)

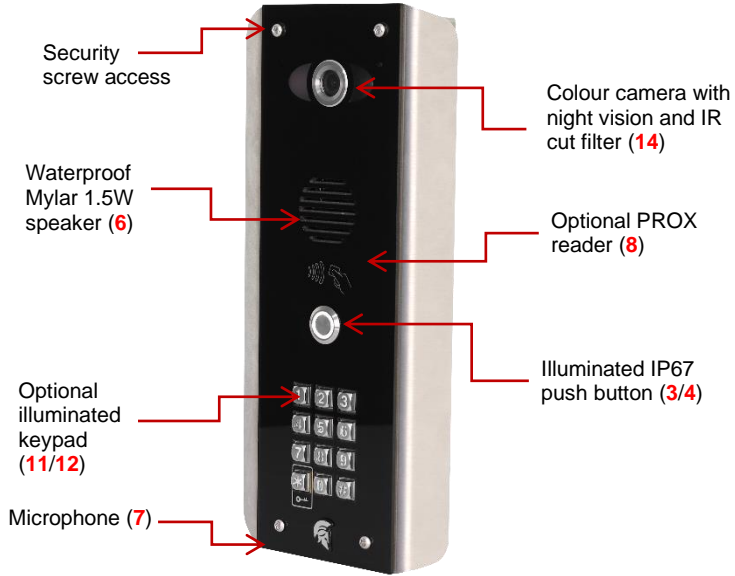

Modular Version (4G Router Separate)

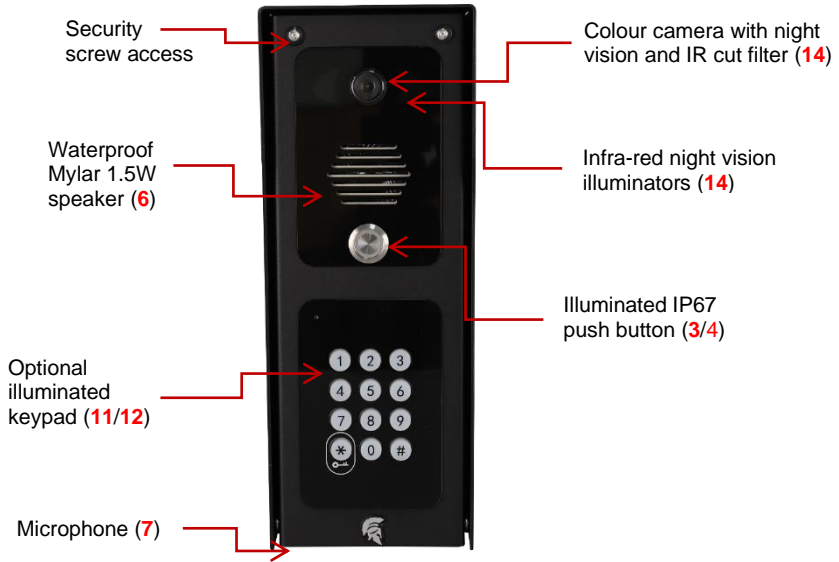

Portrait Version (4G Router Integrated)

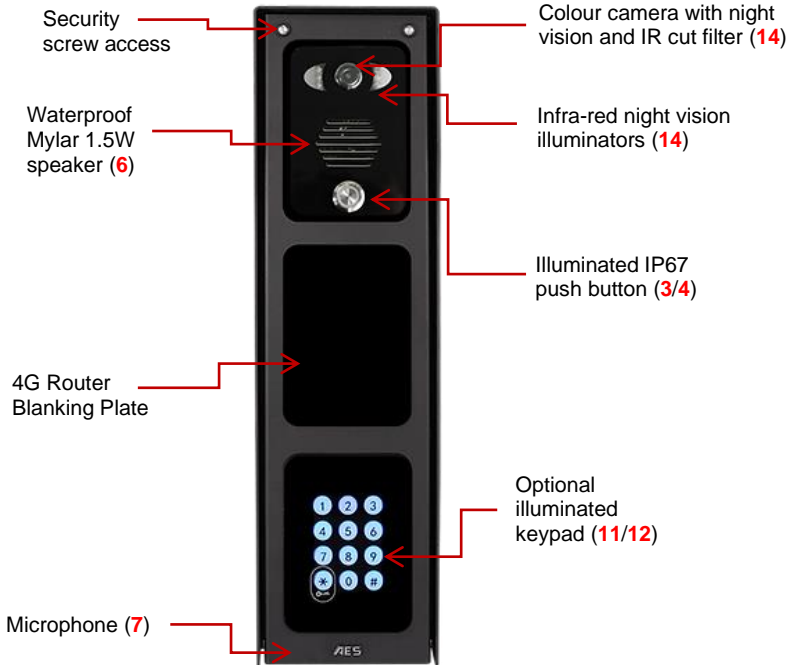

Pedestal Version (4G Router Integrated)



Now let's have a look inside...

Architectural Version (4G Router Separate)

The 4G router and the main intercom module need connected together via a LAN cable and both powered with the supplied power supplies. An active 4G SIM and GSM antenna need to be used.

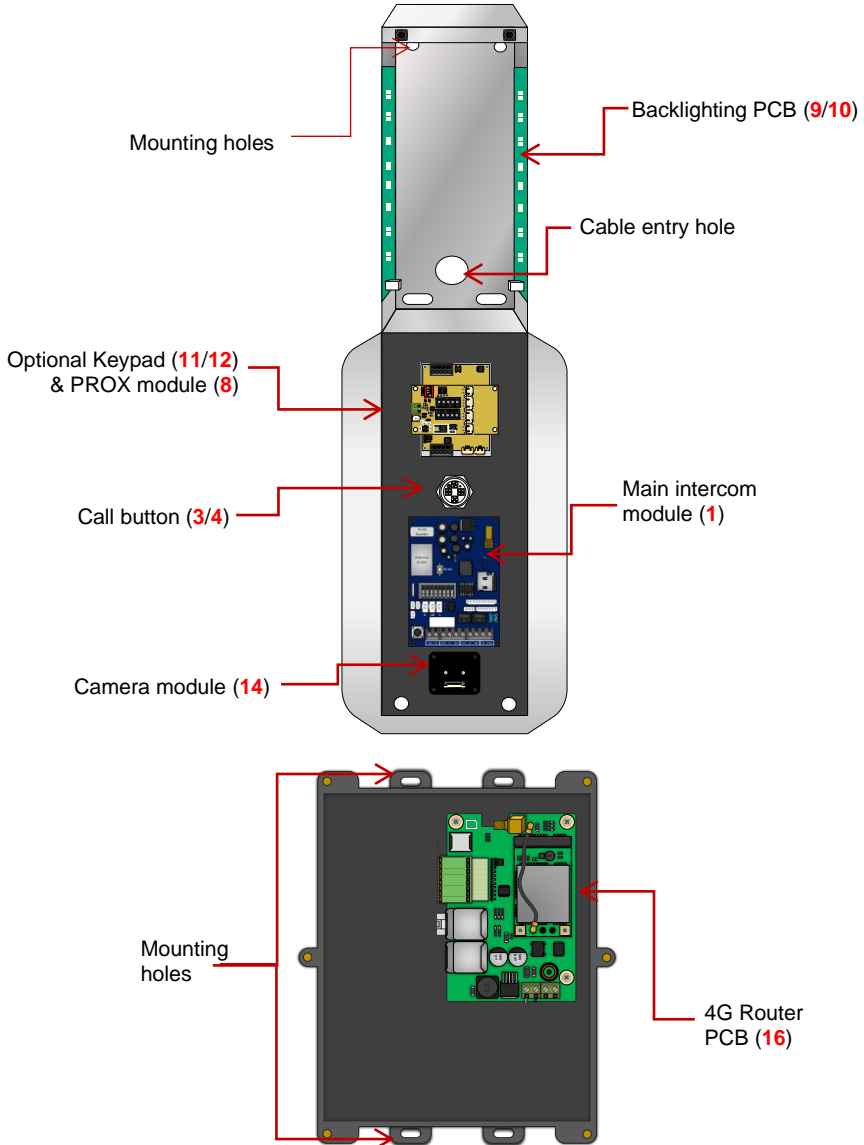

Modular Version (4G Router Separate)

The 4G router and the main intercom module need connected together via a LAN cable and both powered with the supplied power supplies. An active 4G SIM and GSM antenna need to be used.

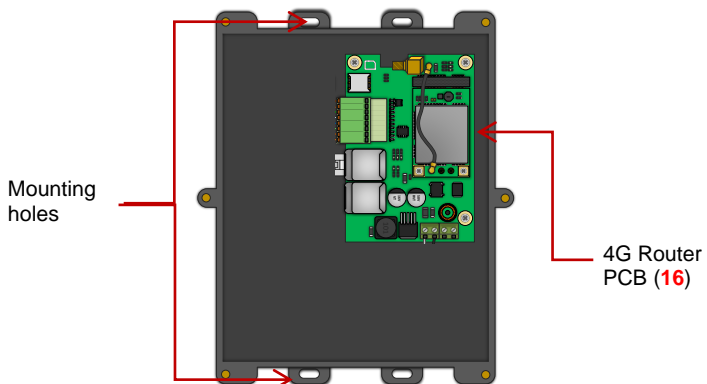
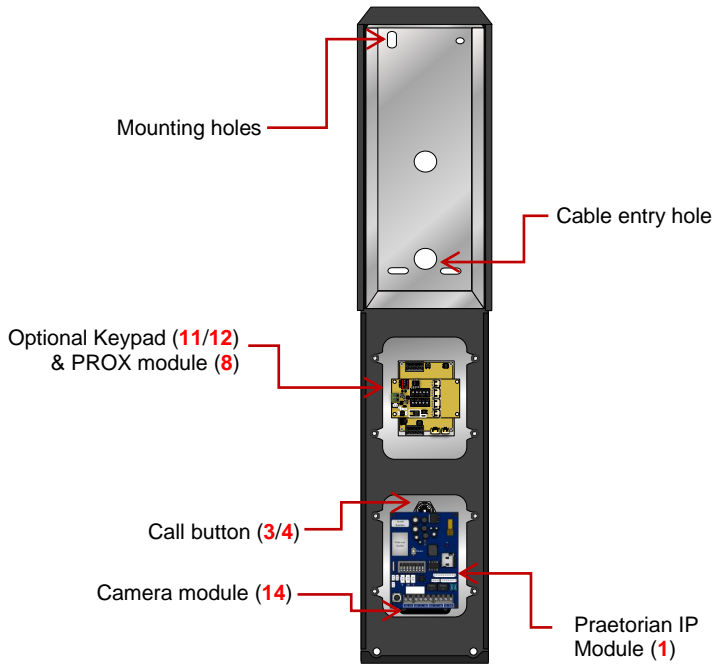

Modular Version (4G Router Integrated)

All components purchased will be pre-connected from factory. Only requiring power to be connected with an active 4G SIM and GSM antenna.

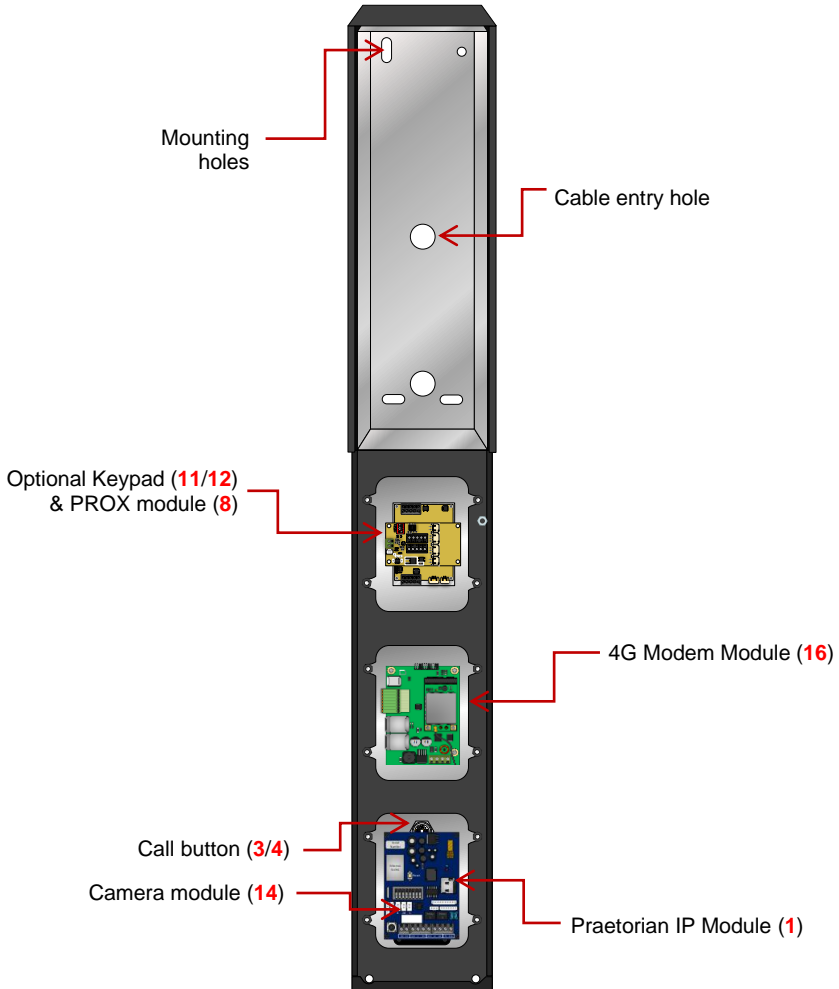

External Power Conditioning Module (surge protection) provided with non-pedestal units.

Pedestal Version (4G Router Integrated)

All components purchased will be pre-connected from factory. Only requiring power to be connected with an active 4G SIM.

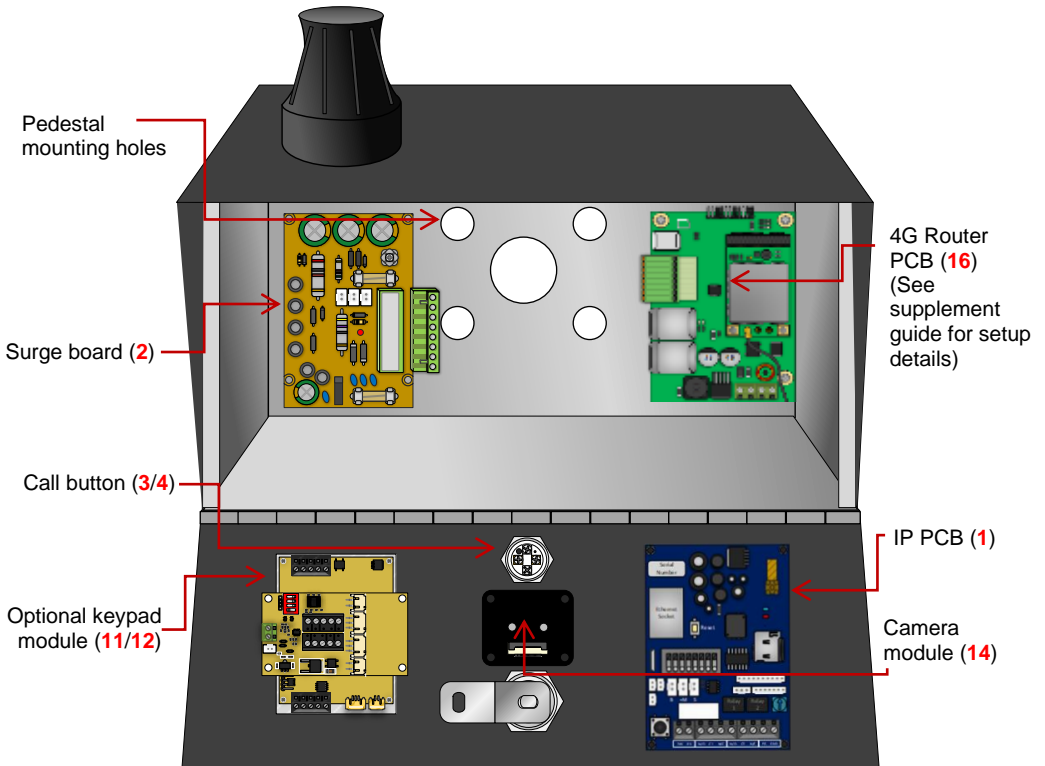

Main WIFI Module (1) in Detail...

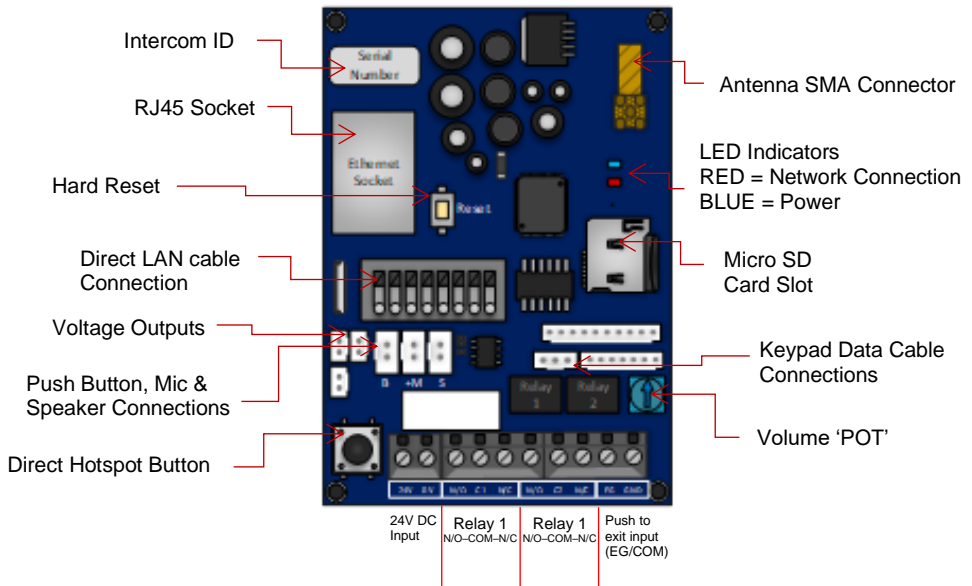

Keypad (11/12) & PROX Module's (8) in Detail

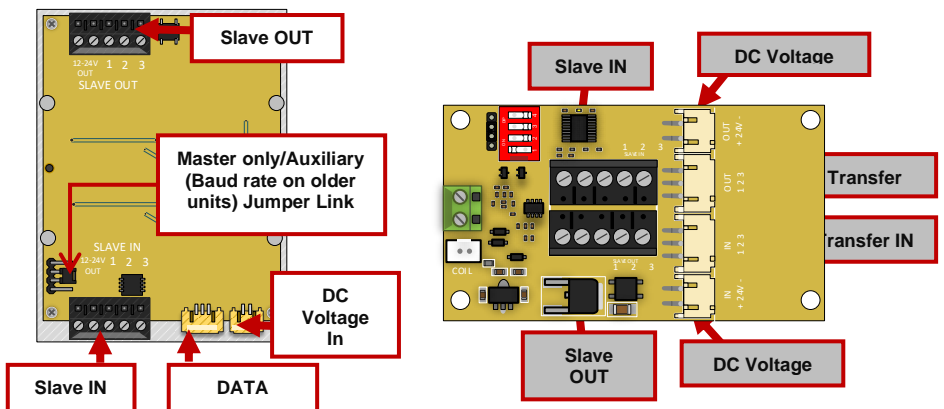

Overview of 4G Router PCB (16)

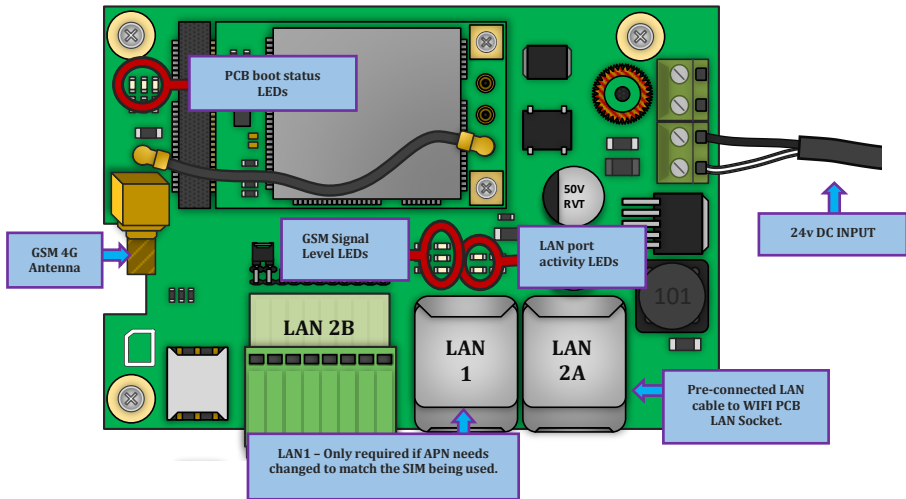

This module will come with the APN pre-set for the VODAFONE SIM that is provided with the unit.

Once the SIM has been setup with a data package then this module will provide an internet connection for the main PCB

Please contact support if you need assistance programming a different APN for another network And you will need to have ready the APN of the SIM card you activate before programming can be done.

Be aware a laptop with RJ45 connection on site will be required to complete this

PCB BOOT STATUS LED's

When the PCB has successfully booted up you should have activity on all 3 LEDs:

RED: Constant ON = **PCB Powered ON** | Constant OFF = **PCB Powered OFF**

GREEN: Steady Flash = **Connected to Network** | Constant OFF = **Not Connected**

BLUE: Steady Flash = **Standby Mode** | Constant OFF = **Booting / OFF**

LAN PORT ACTIVITY LED's

The 2 LEDs behind LAN 1 Port will flash **GREEN** when you have connection activity.

LAN PORT ACTIVITY LED's

The 2 LEDs behind LAN 1 Port will flash **GREEN** when you have connection activity.

Overview of Surge PCB (2)

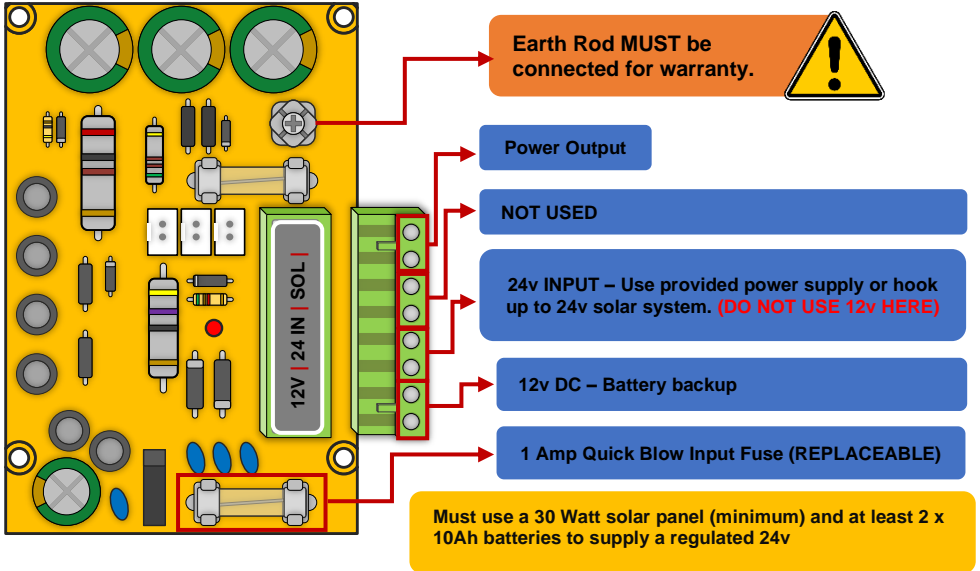

Component Sellable Codes		
	Component	Sellable Code
1	Praetorian PCB	PRAE-PCB
2	Surge PCB	SURGE3
3	Blue push button	BPB-24V
4	White push button	WPB-24V
5	No touch sensor	NT-BUTTON
6	Speaker	SPK-ASSM
7	WIFI mic	WIFI-2-MIC
8	Prox PCB and coil	PROX-PCB-PRIME6
9	Backlighting PCBs (blue)	LEDB-PCBA-ABK-V2
10	Backlighting PCBs (white)	LEDW-PCBA-ABK-V2
11	Blue prime keypad	PRIME-KP-B-KIT
12	White prime keypad	PRIME-KP-W-KIT
13	Cam Security Lock	IBK-LOCK
14	Praetorian Camera	BPRAE-CAM-PCB
15	Camera ribbon cable	BPRAE-CAM-LEAD
16	4G router	ROUTER-4GE-V1

Technical Specifications

GENERAL	
Front Panel	<p>Portrait Orientation AB/ABK = 3mm Acrylic on Architectural Design Marine Grade Stainless Steel BS316 Front Plate</p> <p>AS/ASK = 3mm Marine Grade Stainless Steel BS316 on Architectural Design Marine Grade Stainless Steel BS316 Front Plate</p> <p>FS/FSK = Flush Design Marine Grade Stainless Steel BS316 Front Plate</p> <p>IMP/IMPk = 3mm Acrylic on Imperial Design Marine Grade Stainless Steel BS316 Front Plate</p> <p>Modular = Powder Coated Marine Grade Stainless Steel BS316 Front Plates with 3mm Acrylic on Design Marine Grade Stainless Steel BS316 Modular Plates</p> <p>Landscape Orientation PED = Pedestal Surface Mount</p>
Hood Cover (MOD, IMP(K), PED ver)	Powder coated Aluminium
Mounting Housing (Backbox)	Marine Grade Stainless Steel BS316
Call Button	Stainless-steel button with illuminated LED Ring
Weatherproof	IP55
Approvals	CE, FCC
Dimensions	See Datasheets
Operating Temp.	-25 to +55°C / -13 to 131°F
Power Supply	24V DC
Power Consumption	<p>IP PCB w/Keypad & Prox Standby = 96mA Operating = 500mA Peak = 2000mA</p>
Solar Power	<p>30Watt Solar Panel (minimum) 24V 10AH</p>

System Requirements	<p>Mobile device: Newest iOS on iPhone/iPad, newest Android on Smartphone/Tablet</p> <p>Internet: High-Speed Landline Broadband Internet connection, DSL, cable or fibre optic, no socks or proxy server. Min. suggested upload speed of 1.5mbps,</p> <p>Network: Ethernet Network, with DHCP / WIFI 2.4GHz/5.8GHz (with applicable antenna)</p>
Recommended Installation Height	Camera lens should be at a min. height of 145 cm (57 in). Before the installation please determine your optimal installation height.
Warranty	See www.aesglobalonline.com/warranty
KEYPAD MODULE	
Power Supply	24V DC
Steel Keypad Module	<p>12 Square Metal Keys</p> <p>Blue illumination</p> <p>Keypad Codes configurable via App,</p> <p>Slave connection to allow up to an additional 8 slave devices</p>
Silicon Keypad Module	<p>12 Round Silicon Keys</p> <p>Blue illumination</p> <p>Keypad Codes configurable via App,</p> <p>Slave connection to allow up to an additional 8 slave devices</p>
VIDEO	
Camera	HD 720p, dynamic (VGA – HD)
Lens	120° (D), 109° (H), 65° (V) IR-capable
Display Resolution	<p>Switchable in the app by the Admin user.</p> <p>HD resolution: 1280*720</p> <p>SD resolution: 640*480</p>
Video Codec	H264
Night-Vision	Yes, light sensor, automatic IR-cut filter, 5 Infrared LEDs

Storage	<p>On-Board Micro SD Card Max read capacity 32GB</p> <p>Estimated capacity based on 16GB: 5,592 Video Clips (3MB) {AVI.} 33,500 images (0.5MB) {JPG}</p> <p>Supports Hot Swapping.</p> <p>Auto overwrites oldest data at 70% capacity</p> <p>FAT32 Formatting</p>
---------	---

MOTION SENSOR

Type	Active
Detection Type	Digital (Pixel-based) Changes of pixilation. This is processed by the CPU identifying any major/minor changes in pixels that is defined by a predetermined algorithm.
Range	>5m, depends on environment, distance is fixed
Configuration	<p>Via App, e.g.</p> <ul style="list-style-type: none"> • Sensitivity (1-5) • Enable/disable push notification • Enable/disable detection & recordings.

AUDIO

Audio Components	Speaker and microphone, noise reduction and echo cancellation (ANR, AEC)
Audio Streaming	Two-way, full duplex & half-duplex (switchable in-app)
Audio Codec	PCM/ARAW

NETWORK

WiFi	IEEE 802.11a/b/g/n/ac
WiFi Security	WPA / WPA2 / WPA3
Frequency Range	2.4GHz-2.4385GHz; 5.15GHz-5.845GHz
Ethernet	IEEE 802.3
Supported Protocols	HTTP, HTTPS, SSL/TLS, Bonjour, DNS, RTSP, RTP, TCP, UDP, RTCP, ICMP, DHCP, ARP

THIRD-PARTY INTEGRATIONS

Partners	N/A - Coming Soon
API	N/A - Coming Soon

4G ROUTER

Power Supply	24V DC
Interface	Custom OpenWrt

Antenna Type	SMA
SIM Tray	NANO
LAN Ports	2 x 10/100 Mbps - LAN/WAN
Direct Cable Connection	8 Pin Spring Connector Terminal Block (Linked to 1 x LAN ports)
GSM Modem Models	4G Europe - SIM7600E 4G USA - SIM7600A 4G AUS/NZ - SIM7600SA
Frequency Range	LTE-TDD = B38/B40/B41 LTE-FDD = B1/B3/B5/B7/B8/B20 UMTS/HSPA+ = B1/B5/B8 GSM/GPRS/EDGE = 900/1800MHz
RF Output Power (EIRP)	32.55dBm (GSM 900), 29.73dBm (DCS 1800) 23.77dBm (WCDMA Band I), 23.78dBm (WCDMA Band VIII) 22.79dBm, 22.73dBm, 22.97dBm, 22.35dBm, 22.99dBm (LTE B1, B3, B7, B8, B20)

PHASE 3

Setup

(To be done before installing the intercom)

Modular Version
(4G Router Separate)

Skip to page 30 for modular or pedestal versions!

Configure 4G Router Before Install

Step 1 - Open the intercom.

Loosen top screws

Use Key on lock

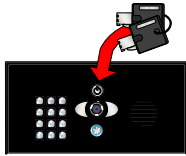

“Portrait” oriented models will have security screws at the top. Loosen only these with the security screwdriver provided.

Pedestal style “Landscape” orientated units will have a locking key.

Step 2 – Insert the SIM and DC Power Supply.

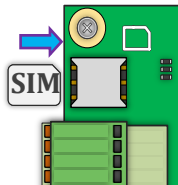

4G Router PCB –
Insert active SIM
& set APN

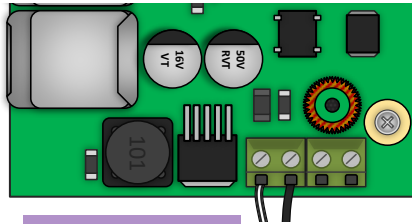

4G Router PCB –
Insert PSU Cables

Power up the 4G router & intercom so that you can perform the configuration with the homeowners' phone beside the intercom.

This router will come with an APN pre-set to match the VODAFONE network. You can skip this page if you are using this network.

If you are using a different network than above, then the router will require the correct APN to be set before full operation.

Tip: Ensure the router is fully operational and providing an internet connection before installing by connecting a computer via LAN cable and test the ability to load a web page.

How To Change Router APN / Check Signal

Step 1:

Connect to the router:

- a) **PC/Laptop** = Connect direct using LAN cable
(Computer LAN port to LAN 2 on router PCB)

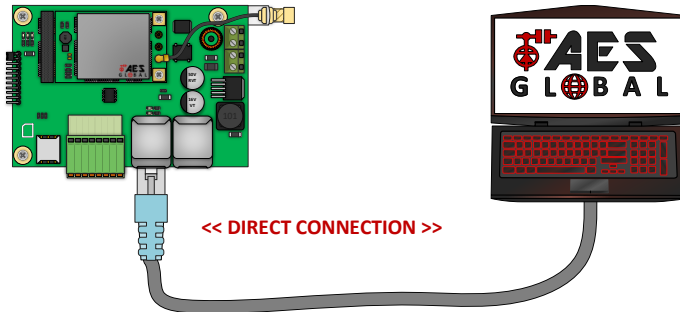

- b) **Mobile** = Connect the AES 4G Router to an available LAN port on another router that has Wi-Fi.

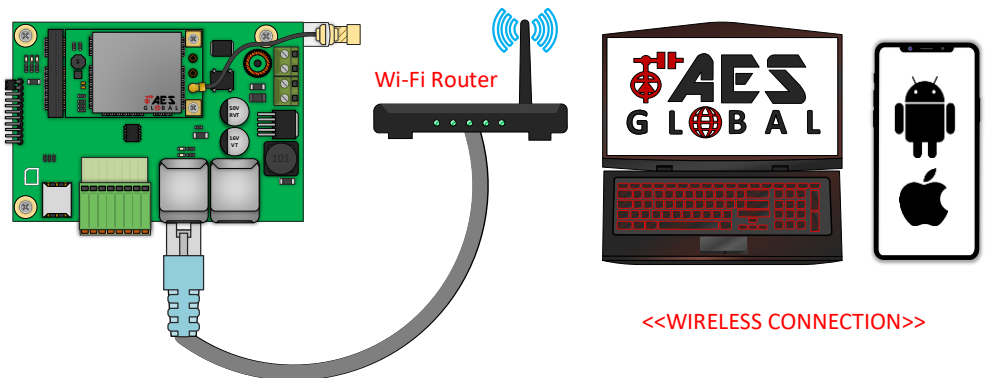

Step 2:

Open web browser and type IP address of the router into the search bar.
'192.168.1.251'.

NOTE: If it is the first time connecting to the control panel you might be met by a security certificate check screen on your device. Please see below example for Apple and Android devices on how to proceed past this screen and gain access to the control panel

Private Connection Security Screen for Apple, Android & Browsers

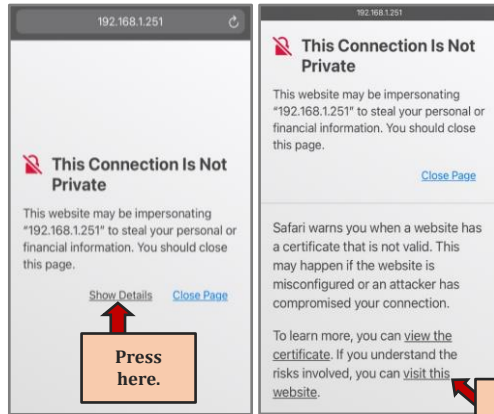

Then select 'visit this website.'

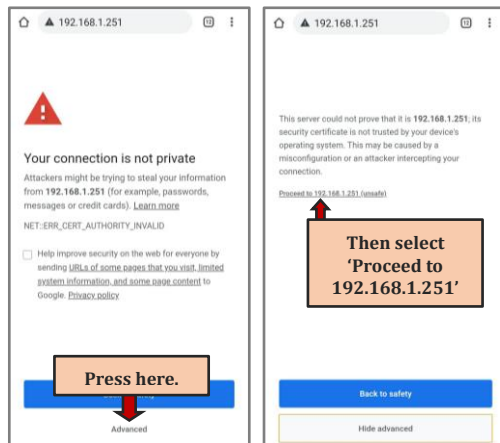

Step 3:

Login. Default username and password are both set as 'root' then click Login.

Step 4:

Select the correct APN from the list.

If your required APN is not listed you can select the '- - custom - -' option which will allow you to enter the APN manually.

Once your desired APN has been selected press '**Save & Apply**'.

Once your desired APN has been selected press '**Save & Apply**'.

Step 5:

You can now proceed to configure the intercom PCB in the following steps to make sure it comes online and test to ensure it functions as expected.

Configure Intercom Before Install

Step 1

Once the 4G Router has been fully configured and you have an internet connection you can proceed to attach the intercom to the app and perform initial testing.

Note: If you skip this step and proceed directly to installation, technical support may request you go back and perform this step before diagnosing further.

Step 2 - Download and install the app on the end-user's phone.

Search for **Praetorian Guard** and find the icon, or scan the QR code if the phone has a QR scan app.

Note: Be sure to accept ALL permissions during install, otherwise you will experience problems later!



Tip: Slight differences will be seen between the Android and iOS app versions, any major differences will be highlighted in the screenshots below.

Please ensure you check the app for updates at least once a month.

Step 3– Connect 24v DC power with the power supply provided.

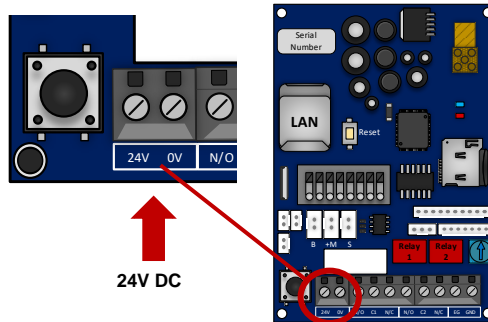

PHASE 3

Setup

(To be done before installing the intercom)

Modular Version
(4G Router Integrated)

Configure 4G Router Before Install

Step 1 - Open the intercom.

Loosen top screws

Use Key on lock

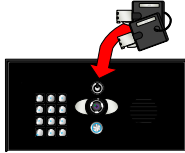

“Portrait” oriented models will have security screws at the top. Loosen only these with the security screwdriver provided.

Pedestal style “Landscape” orientated units will have a locking key.

Step 2 – Connect 24v DC power with the power supply provided.

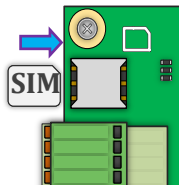

4G Router PCB –
Insert active SIM
& set APN

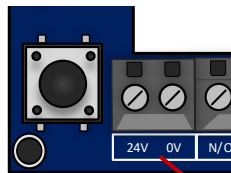

24V DC

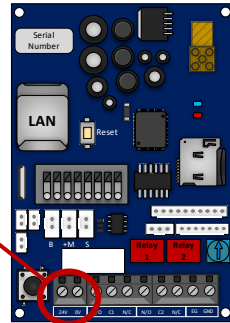

Power up the 4G router & intercom so that you can perform the configuration with the homeowners' phone beside the intercom.

This router will come with an APN pre-set to match the VODAFONE network. You can skip this page if you are using this network.

If you are using a different network than above, then the router will require the correct APN to be set before full operation.

Please see the ‘**4G Router - Change APN**’ document available on our website for detailed information on how to do this.

Tip: Ensure the router is fully operational and providing an internet connection before installing for convenience.

How To Change Router APN / Check Signal

Step 1:

Connect to the router:

- a) **PC/Laptop** = Connect direct using LAN cable
(Computer LAN port to LAN 2 on router PCB)

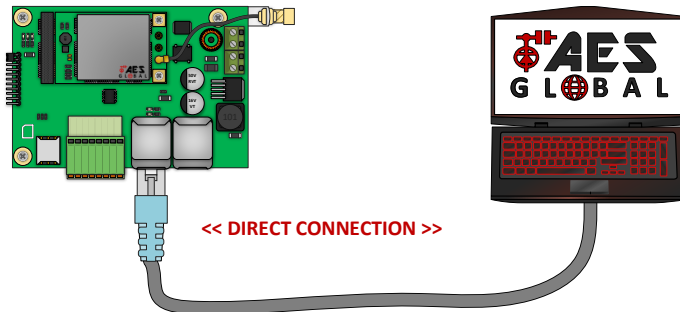

- b) **Mobile** = Connect the AES 4G Router to an available LAN port on another router that has Wi-Fi.

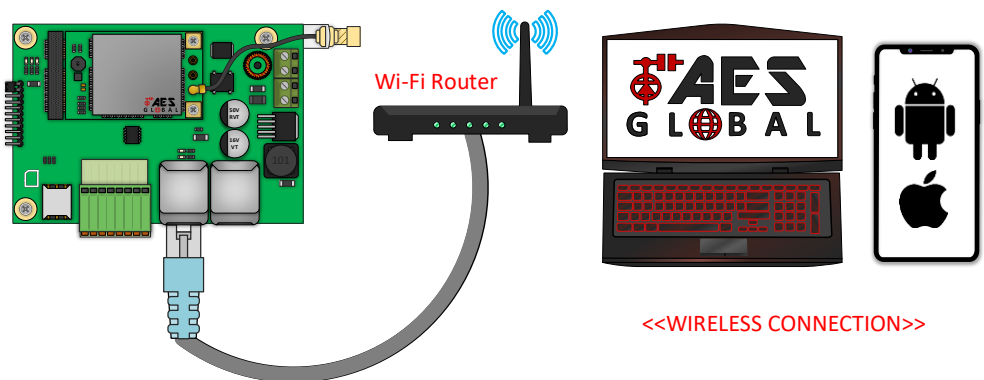

Step 2:

Open web browser and type IP address of the router into the search bar.
'192.168.1.251'.

NOTE: If it is the first time connecting to the control panel you might be met by a security certificate check screen on your device. Please see below example for Apple and Android devices on how to proceed past this screen and gain access to the control panel

Private Connection Security Screen for Apple, Android & Browsers

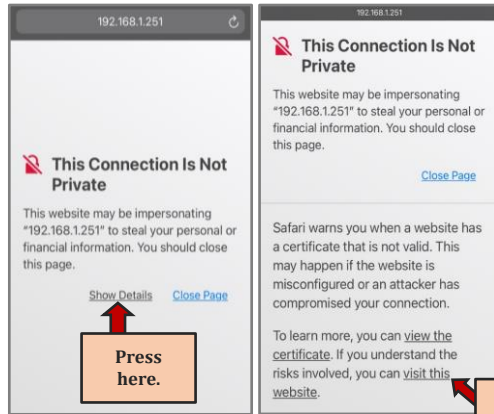

Then select 'visit this website.'

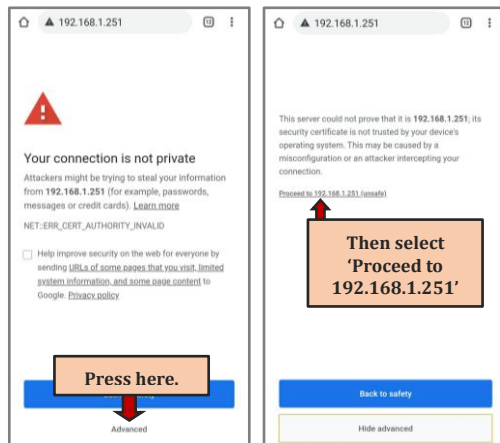

Step 3:

Login. Default username and password are both set as 'root' then click Login.

Authorization Required
Please enter your username and password.

Username

Password

Login

Once the details have been entered press 'Login'.

Step 4:

Select the correct APN from the list.

If your required APN is not listed you can select the '- - custom - -' option which will allow you to enter the APN manually.

Once your desired APN has been selected press 'Save & Apply'.

Signal Level and Network Mode

Signal: 4G

Vodafone UK <-wap.vodafone.co.uk>
Vodafone UK <-wap.vodafone.co.uk>
O2 UK <-wap.o2.co.uk>
EE UK <-everywhere>
Three UK <-three.co.uk>
Orange UK <-orangenternet>
Virgin UK <-goto.virginmobile.com>
T Mobile UK <-general.t-mobile.uk>
Tesco UK <-prepay.tesco-mobile.com>
ID UK <-id>
Giff Gaff UK <-giffgaff.com>
Lebara UK <-uk.lebara.mobi>
Vodafone UK2 <-pp.vodafone.co.uk>
Smarty UK <-mob.asn.net>
Cosmote <-internet>
O2 UK2 <-mobile.o2.co.uk>
Jersey Telecom <-pepper>
Lyca UK <-data.lycamobile.co.uk>
Talk talk UK <-mobile.talktalk.co.uk>
Sky Mobile UK <-mobile.sky>
BT Mobile UK <-btmobile.bt.com>

1-12 Poor 13-20 Medium 21-31 Good

**For optimal performance,
minimum signal level required is
10 on 4G mode or 13 on 3G mode**

Once your desired APN has been selected press 'Save & Apply'.

Step 5:

You can now proceed to configure the intercom PCB in the following steps to make sure it comes online and test to ensure it functions as expected.

Configure Intercom Before Install

Step 1

Once the 4G Router has been fully configured and you have an internet connection you can proceed to attach the intercom to the app and perform initial testing.

Note: If you skip this step and proceed directly to installation, technical support may request you go back and perform this step before diagnosing further.

Step 2 - Download and install the app on the end-user's phone.

Search for **Praetorian Guard** and find the icon, or scan the QR code if the phone has a QR scan app.

Note: Be sure to accept ALL permissions during install, otherwise you will experience problems later!



Tip: Slight differences will be seen between the Android and iOS app versions, any major differences will be highlighted in the screenshots below.

Please ensure you check the app for updates at least once a month.

Step 3– Connect 24v DC power with the power supply provided.

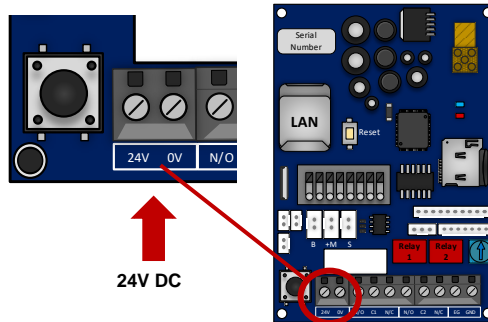

PHASE 3

Setup

(Continued...)

4G Setup Intercom on App

Once you have the router setup correctly and have internet access then follow the steps below.

Option A - Add Intercom Manually

Step 1 – Record the Intercom ID

The intercom ID number can be found on a sticker beside the LAN port connection.
(RJ45 connector may need removed to see the full ID.)

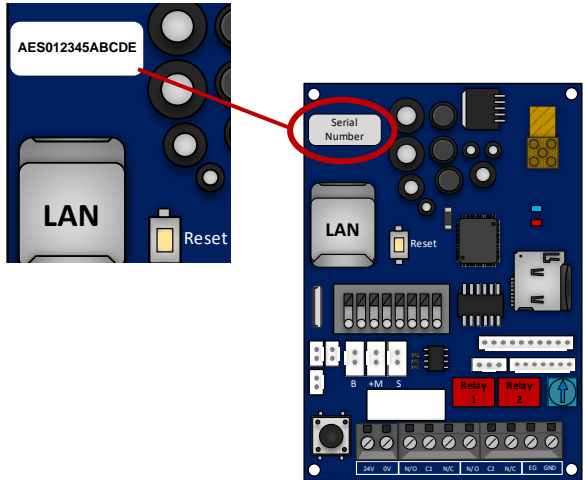

Step 2a, 2b, 2c – Use Intercom ID to add to the app manually.



Step 3 - The intercom is now added to your device and should show Online.

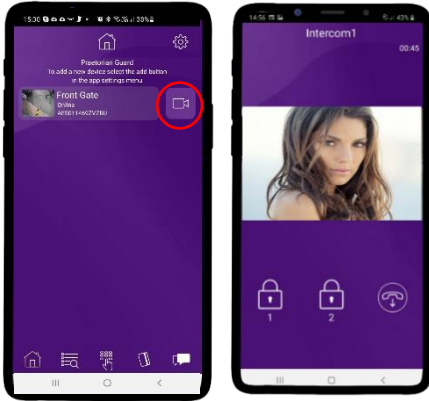

If you can see live video and hear audio, the intercom has successfully connected to the network. If for some reason this does not work, check the LED indicators on the RJ45 socket on the PCB to ensure it is connected correctly to the network.

Diagnostic Tips

1. Intercom is showing online status, but the video feed shows “fetching”.

A. This can be caused by poor power cable extended to the intercom, weak GSM signal on the router.

2. Intercom is not showing online status.

A. This can be caused by weak GSM signal on the router. Or no internet connection on the router due to incorrect APN setting

3. I can see video but there is no audio on the phone or there is no audio at the intercom.

A: Possibly permissions for the app were not accepted during app install. Check microphone permissions for the app in the phone settings.

4. The status is showing online, then connecting, then online again.

A: This is normal when a phone roams between two Wi-Fi connections, or between Wi-Fi and data.

If you are suffering from any connection issues you can follow Option B below to ensure the main PCB is operating correctly.

Option B - Add Intercom via local hotspot

Step 1 - Disconnect the LAN cable that is connected

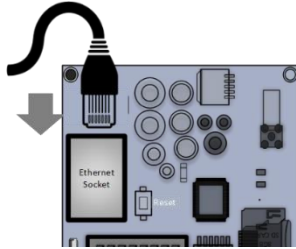

Step 2 - Press and HOLD the code button for approx. 3-5secs and release. A tone will be heard.

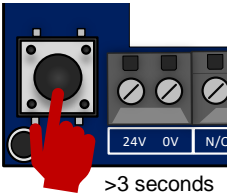

The intercom will now begin to transmit its own Wi-Fi network using the intercom ID reference. (E.g., AES-XXXXXX-XXXX)

Tip: This will clear any currently stored WiFi connections from the system. You will need to reconnect to the WiFi network to allow the system to function again after pressing this button.

Step 2a – Find The WiFi Hotspot ID

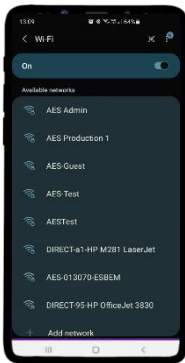

With the user's phone, search for available Wi-Fi networks and connect to the 'Intercom ID' network.



TIP: Your phone needs to be within range of the intercom to detect this network.

Step 2b – Enter password to connect via WiFi

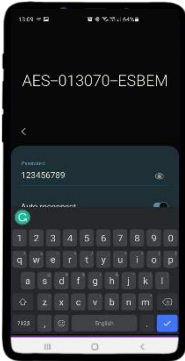

Enter the default pass code **123456789** and the users' phone should now be connected directly to the intercom.

Android: Press **CONNECT**
Apple: Press **DONE**

Note: Your device may state there is no internet connection. This is normal. Accept any prompts to stay connected for the next steps.

Step 3a, 3b, 3c – Select 'SEARCH INTERCOM ID IN LAN' button.



Step 3e – Enter user login details

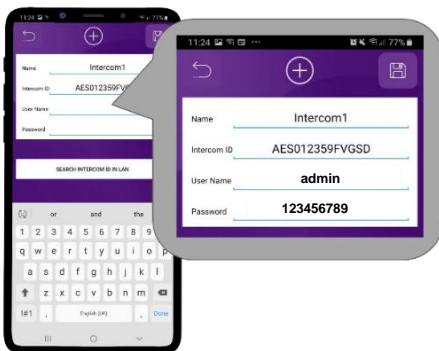

Step 4

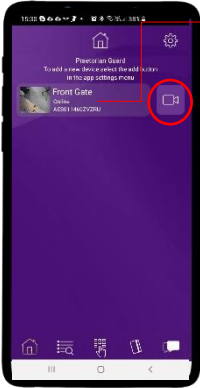

Should be showing ONLINE status.

Press the Video icon to view live video.

Note: at close proximity, you will experience acoustic feedback. This is normal.

If you can view live video, and hear acoustics, then this proves that the intercom hardware is working as it should.

Note: The intercom and phone are directly connected in a point-to-point link. It will still need connected to the network to be fully operational remotely.

Step 5a, b, c – Reconnect the LAN cable

Although we know the intercom is fully operational, we now need to connect it to the internet via the 4G router.

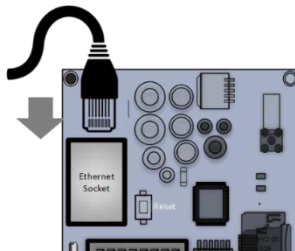

Step 6 – Reboot the intercom

The intercom will now re-boot and show ONLINE if the 4G router is configured correctly and provides an internet connection.

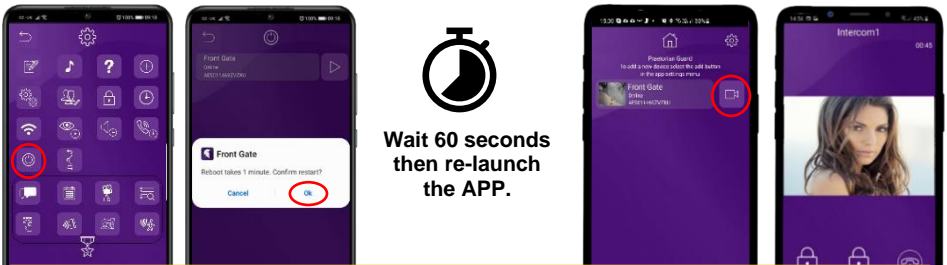

Note: If you can see live video and hear audio, the intercom has successfully connected to the network.

If for some reason this does not work, connect the 4G router to a computer via a LAN cable and check the GSM signal and APN settings.

Time Sync & Testing

Step 1 - Ensure the intercom is now added to your device and should show Online.

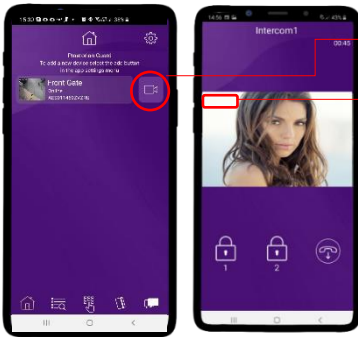

Press the camera icon to view the camera feed

Check the date/time stamp. The default date when the intercom has been reset is 1/1/1970.

If the date has not updated automatically follow the steps below to correct this.

Note: If the date stamp is incorrect it will prevent notifications being sent to the connected devices causing the user to miss calls.

If the time stamp is incorrect it will affect the accuracy of any recorded events in the events log and prevent any auto updates from successfully downloading.

Step 2 – Clock Sync

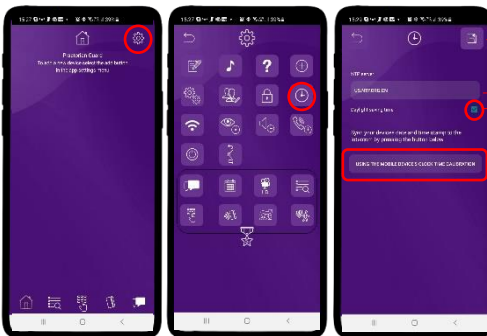

Save Settings

Select NTP Server

Enable or disable daylight saving time.

Sync your device time to the intercom

Note: You can choose any NTP server from the list. This is used to get a base for the current time. It will be adjusted to your time zone automatically when the calibration button is selected.

Step 3 – Confirm intercom timestamp is now correct.

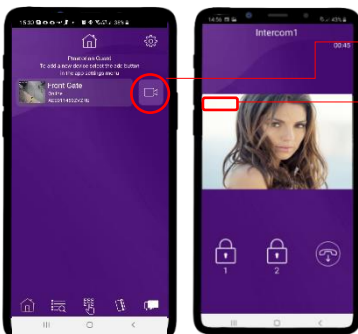

Press the camera icon to view the camera feed

Check the date/time stamp.

Step 4 – Close the app

PUSH notifications may not show while inside the app so to test that the PUSH notifications are working correctly you need to close the app.



Android: Select the 'back' button and then the 'EXIT' door icon will appear on the bottom left, tap this to completely close the application.

Step 5 - Press the call button.



The intercom will send a PUSH notification message via Google™ PUSH notification service through the internet to the phone.

The notification will need to be accepted and then the APP will launch to reveal the visitor and give the user an opportunity to either accept or reject the call.

The process to answer a call will depend on what device is being used. Please see next pages for the different process between Android and Apple.

Answering on Android

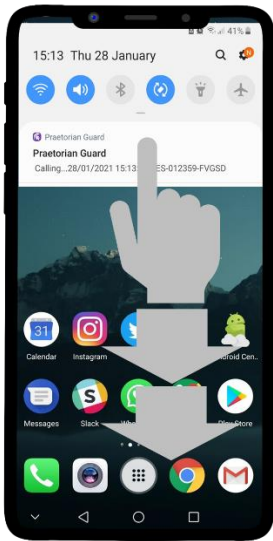

Swipe down to reveal the android notifications and press the Praetorian notification

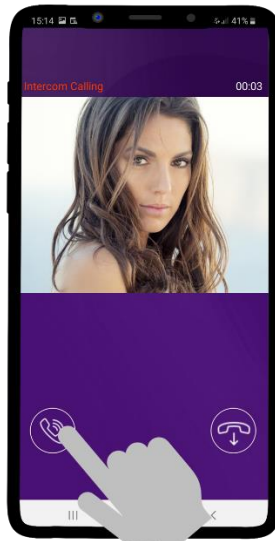

This will launch the app and reveal the answer screen. Press the icon shown to answer the call if you wish to speak to the visitor

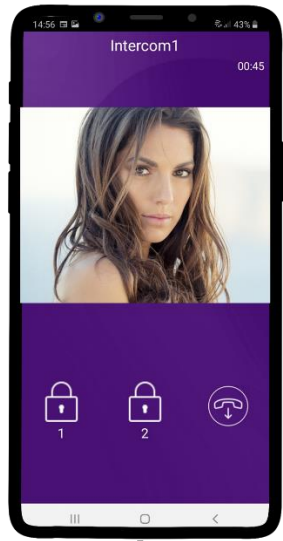

Press the appropriate lock icon (depending on which relay your installer has connected to the gate or door)

Answering on iOS (Apple)



Swipe the notification left



Press "VIEW"

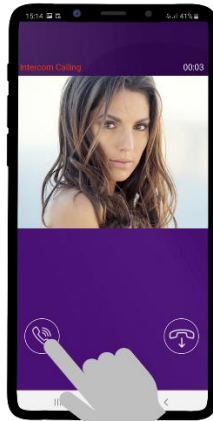

Phone will now launch app. Press icon to answer



Note: Various versions of IOS and Android OS will have different notification acceptance techniques. Please refer to online support for your device if needed.

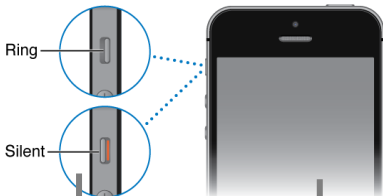

TIP: Make sure ringer switch is ON and volume is turned up.

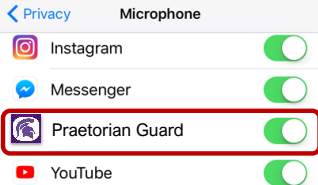

TIP: If there is no voice from the speaker at the gate, check the iPhone microphone permissions in Settings > Privacy / Microphone

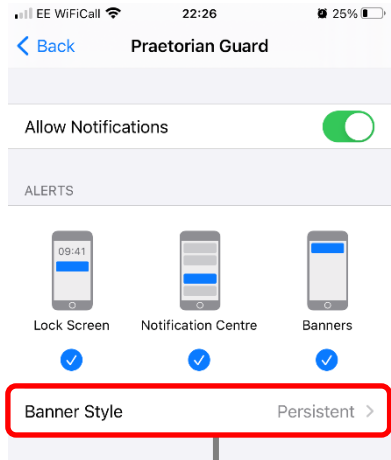

TIP: If you don't get notifications then check settings/notifications and select the app.

PHASE 4

Installation

(Only to be done after the unit is successfully proven to be operating on the network during setup on phase 3.)



**ATTENTION IMPORTANT
INFORMATION**



Recommendation!

Most technical calls received are due to installers using CAT5 or alarm cable to power the unit. Neither are rated to carry enough power (2 amp peak). Please use following cables:

0-2 (0-6 ft) use min 0.5mm² (18 gauge).

2-4 (6-12 ft) use min 0.75mm² (16 gauge).

4-8m (12-24 ft) use min 1mm² (14/16 gauge).

INSECT INGRESS WILL INVALIDATE WARRANTY

We recommend sealing all entry holes for prevention of insects that can cause issues with a risk of shorting out components.



How to Achieve & Maintain IP55 Rating

The IP55 rating attached to this unit is only achieved if the below steps have been followed. This is to prevent any unwanted water and/or bug ingress that can cause various issues with functionality and will void warranty if not followed.

Step 1 – Mount to location

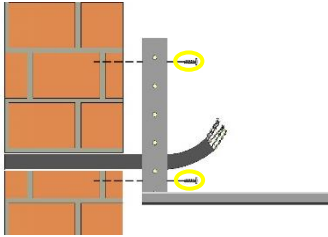

Use the pre-drilled mounting holes and cable cut outs to connect the intercom to the mounting option chosen.

Step 2 – Seal unit

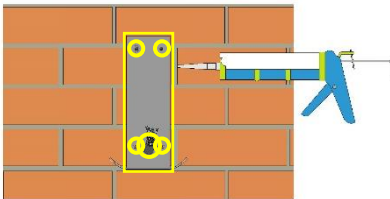

Seal all mounting or cable cut outs by using sealant such as silicone.

Ensure that any products being used are safe to use as some products can cause damage to the unit and/or the mounting location.

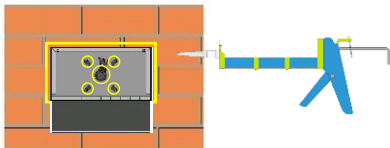

If surface mounting seal around the back box especially when used on an uneven surface.

Step 3 – Close unit

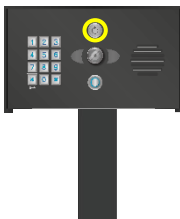

Pedestal Design



Architectural,
Imperial & Modular
Design

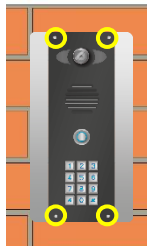

Flush Design

Ensure the security screws or cam lock is adequately closed to ensure a correct seal.

Power & Antenna

This intercom comes with a 24v dc power supply. The intercom requires up to 2 amps peak demand at times, therefore power cable is of extreme importance.

Please adhere to the cable thickness guide below or the device may be damaged and rendered out of warranty by the manufacturer.

4G Router Integrated

Tip: Most connections will be pre-wired.
Only connections needed during installation are:

- GSM Antenna
- SIM Card
- 24v DC Power

4G Router Separate

Solar Power

You can use solar power if required. You will require a DC voltage regulator applied at the gate board end as the voltage output can vary and cause too high a voltage, which will damage the intercom if over the 26v DC.

Our systems would require as a minimum a 30W of solar panel capacity and 10ah battery capacity for our intercoms.



Notes:

On the WIFI units the draw is 96mA standby, 500mA calling with up to 2A spikes.

Up to 2 meters (6 feet) use minimum 0.5mm / 18 gauge cable.
Up to 4 meters (12 feet) use minimum 1mm / 16 gauge cable.
Up to 8 meters (25 feet) use minimum 1.5mm / 14 gauge cable

Note: Please adhere to the cable thickness guide or the device may be damaged and rendered out of warranty by the manufacturer.

Power Consumption:
Standby = 96mA
Calling Out = 500mA

Battery Backup Option

If you wish to prevent your intercom from losing power in the event of a power outage, we recommend using a battery backup.

Diagrams below are for demonstrational use only

POWER ON

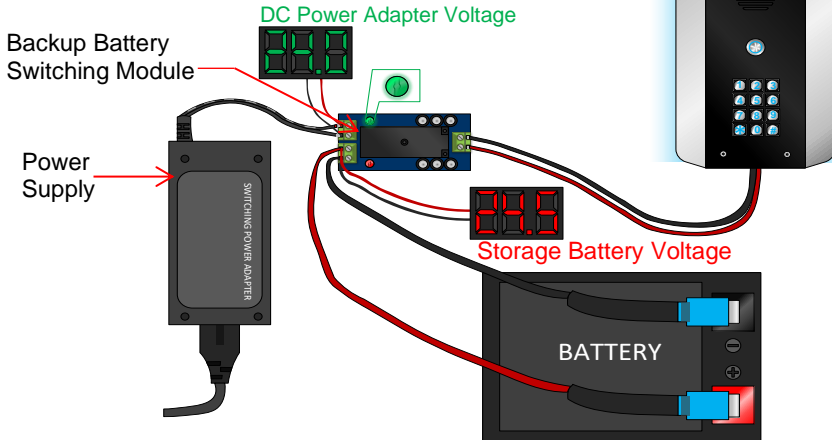

POWER OFF

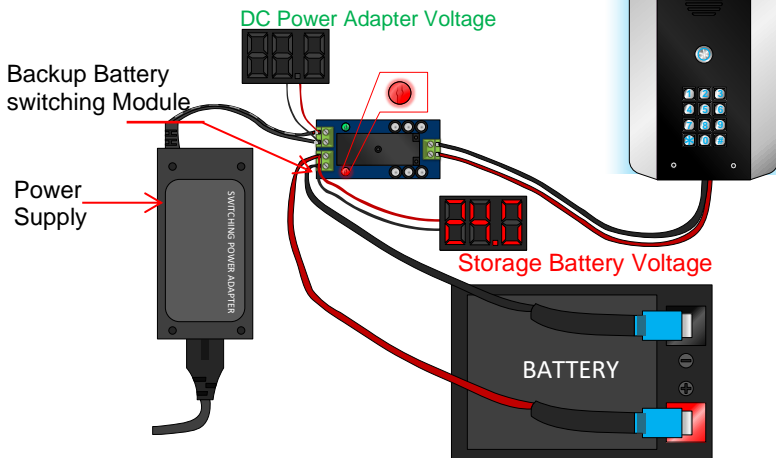

When the backup battery switching module detects a loss in power from the DC power adapter it switches over to the Backup Battery.

Battery and switching mechanism sold separately

Wiring Example

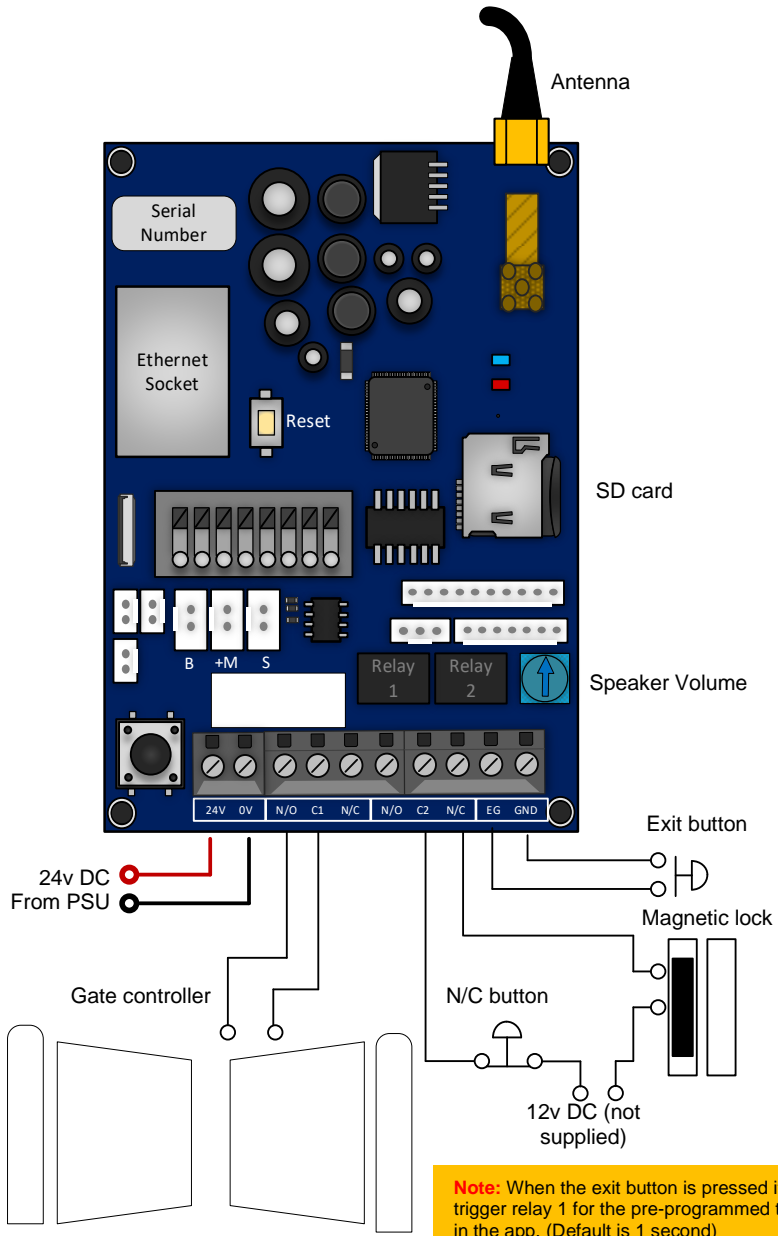

Connecting Slave Devices

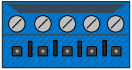

SLAVE OUT



SLAVE IN

Colour code is for illustration purpose only. Terminals are black

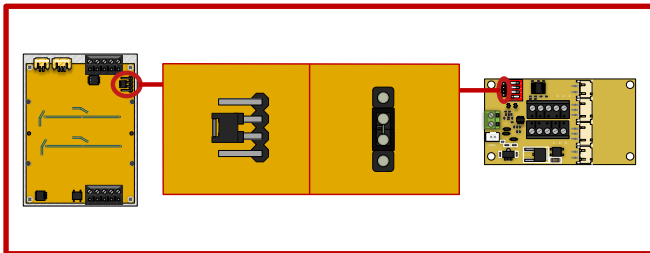
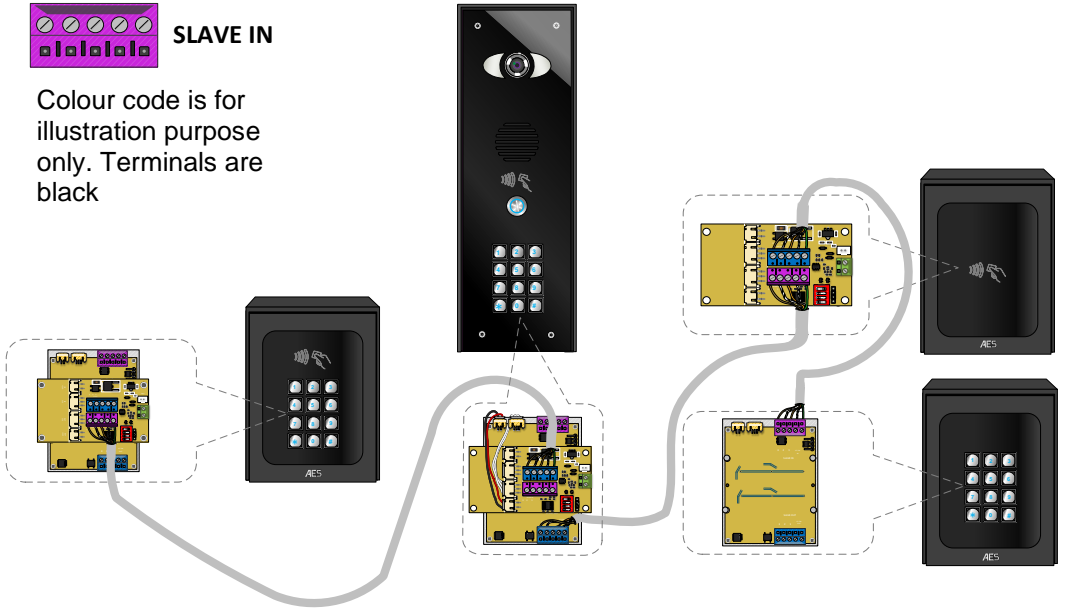

Keypad and prox must have jumper link on for this method to work.

Power cable specifications: CAT 5 cable – 50m per power supply with a max of 2 devices

Adding Additional APP Users

Additional users **MUST** be added with individual usernames. Do **NOT** use the same username.

Step 1

On the **Admin user phone**, create a new username and password for any additional phones which you wish to add, as follows.



Step 2

On a **new phone** or tablet, perform the following steps to log on to the intercom with the details which have been created by the ADMIN phone above...



Note: Maximum 8 separate users and devices. Each device connected must be logged in with their own user account for correct operation. Only ADMIN can change critical system settings of the intercom.

Sound, Volumes and Speech

This intercom is capable of full duplex speech, which means two people can have a conversation and appear to speak at the same time. Since various manufacturers of android phones, iPhones and tablets all differ in acoustic performance, and different users may require varying levels of volume on their own handset, it may be possible to setup some devices in full duplex mode, but others may need to be set in half duplex mode (phone user will press to talk). This may also be required if a phone is in a particularly noisy environment, or the intercom is located near a busy main road with high levels of traffic noise.

Intercom Volume

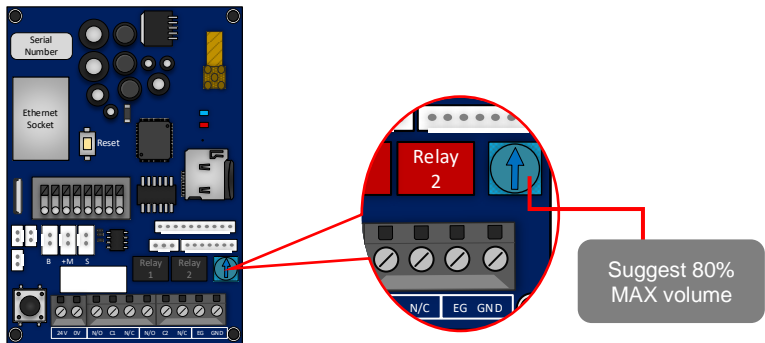

Intercom & Device Sound Options

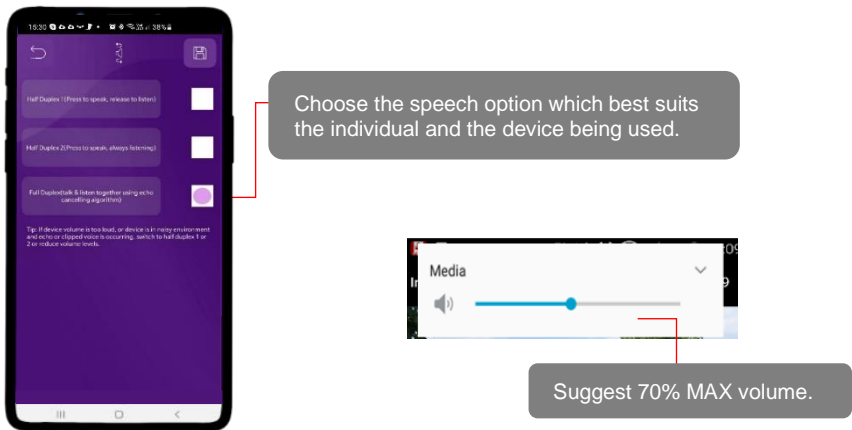

Note: If the phone volume is too high an echo may be heard by the visitor at the intercom.

Using Keypad Codes

Ensure you program a keypad code in the app first then follow the steps below to use them on the keypad to gain entry.

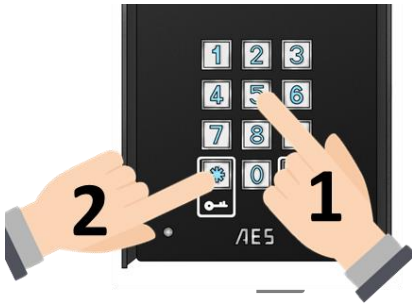

Enter pre-programmed 4-6 digit code., followed by the * key to confirm

Tip: Press * to confirm keypad code

PHASE 5

Advanced Setup

(Only to be done after the unit is successfully proven to be operating on the network after installation)

Feature Shortcuts

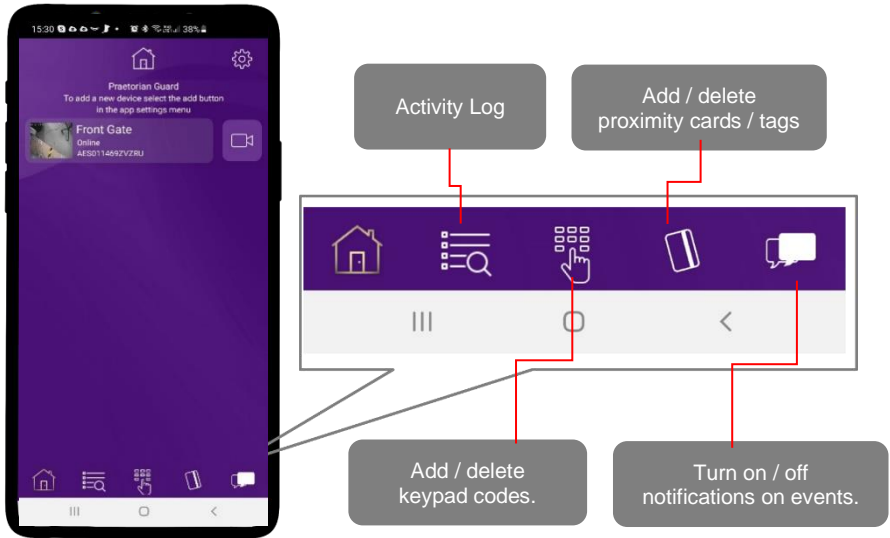

Settings Overview

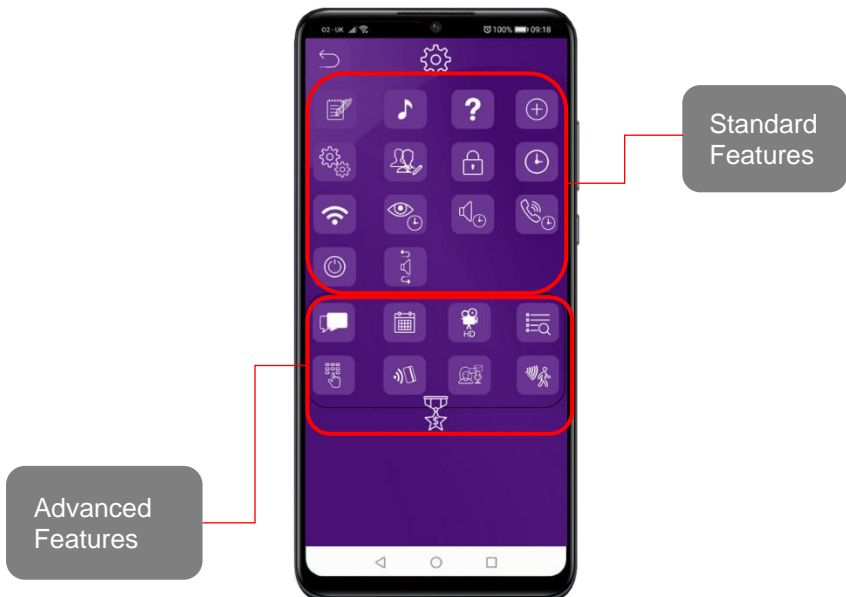

Standard Features

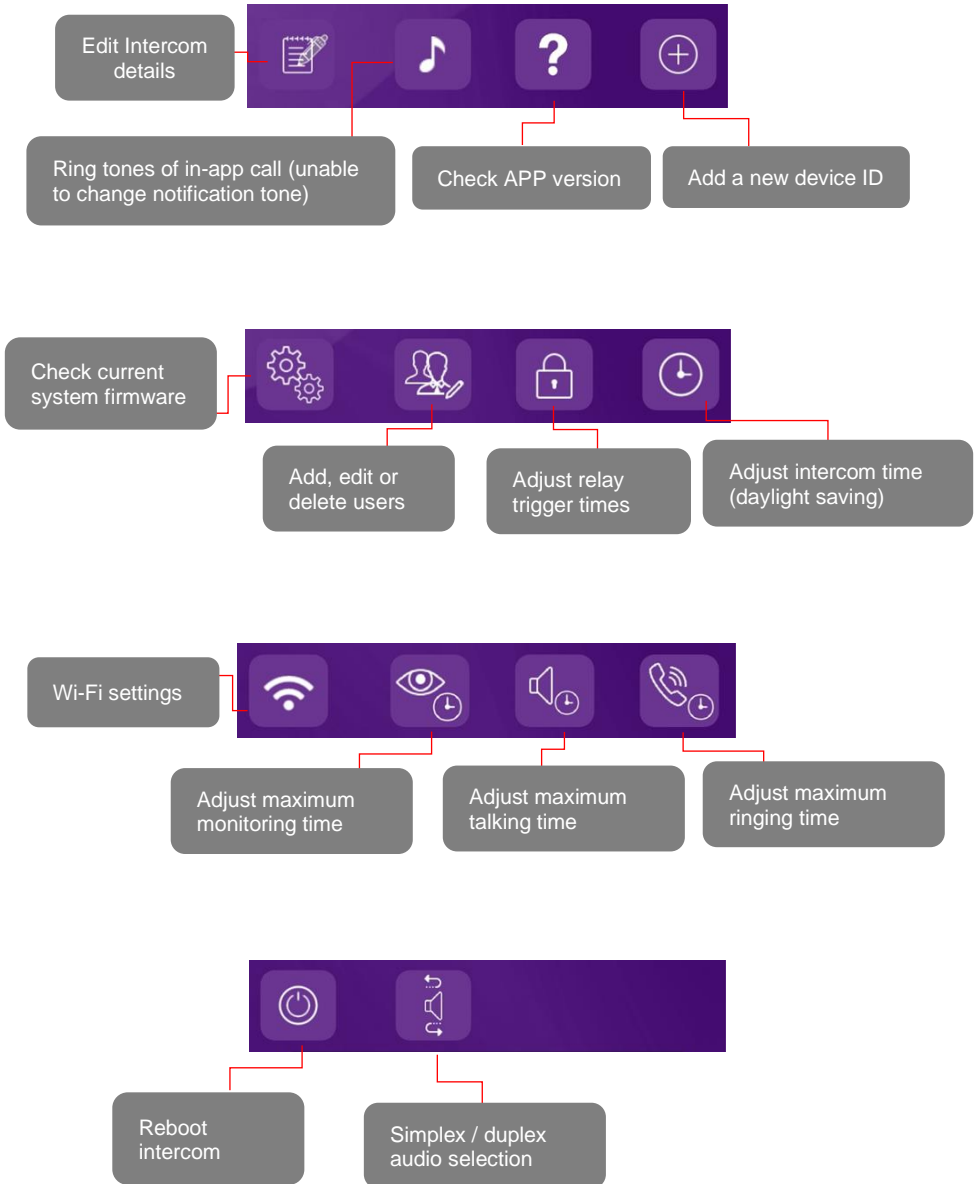

Edit Intercom Details

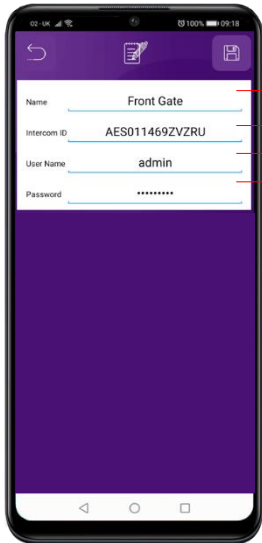

Change the name of the intercom

Intercom ID cannot be changed. Follow the add as a new device steps if ID is incorrect.

Change the username

Change the password

Add a New Device ID

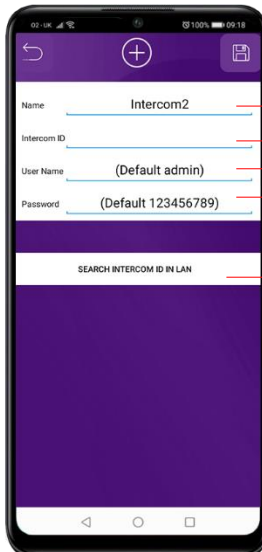

Name the intercom

Intercom ID can be added manually or auto filled by using the 'SEARCH INTERCOM ID IN LAN' button

Enter username, setup by the ADMIN

Enter password, setup by the ADMIN

If you are connected via LAN you can pull the ID via the network

Ringtones of In-app Call

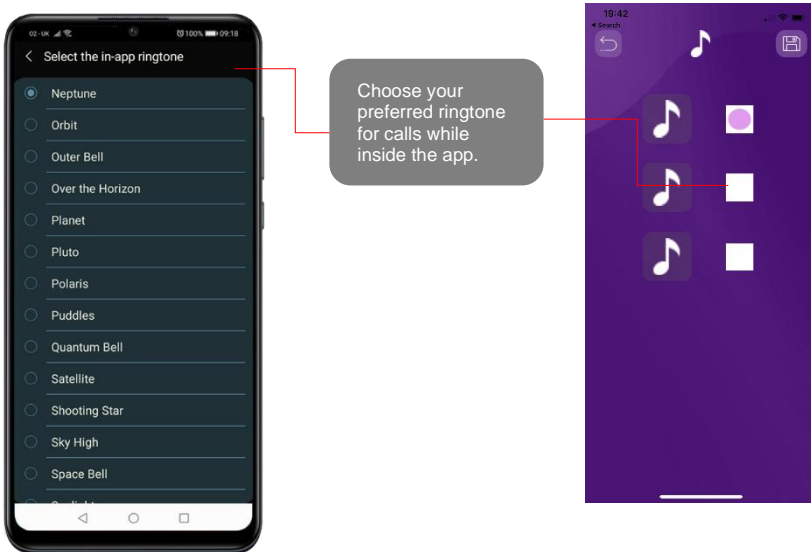

Note: The default call notification tone heard while not in the app cannot be changed.

Check APP version

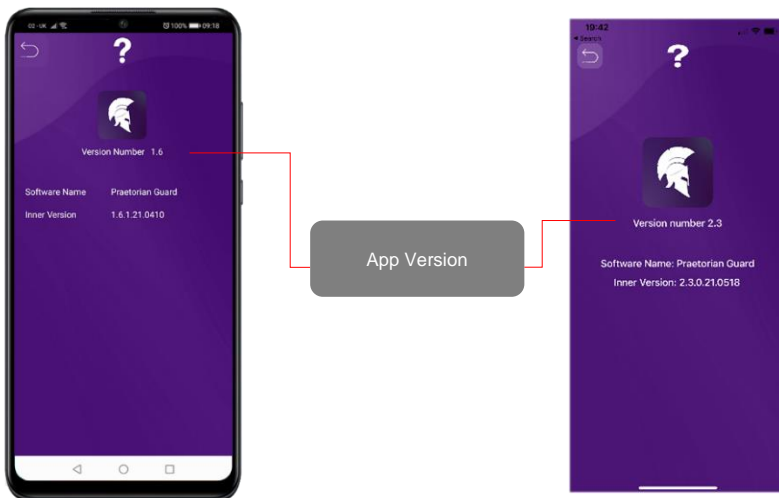

Note: Check the Google Play or the Apple app store to ensure you are using the most recent version.

Check Intercom Firmware



Intercom Firmware Version

Note: See 'Firmware Updates' for more info.

Add, Edit or Delete Users & Logins



Add New User

Edit User

Delete User



Username

Password

Cancel

Save

Note: Administrator account cannot be deleted but the password can be edited by selecting the pencil icon to the user.

Adjust Relay Trigger Times

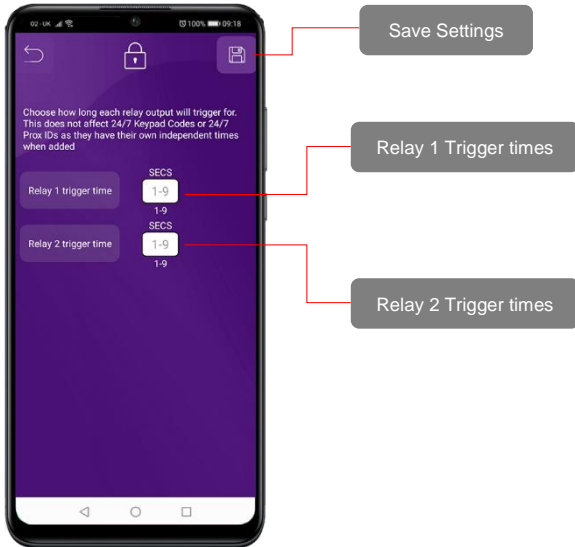

Adjust Intercom Time

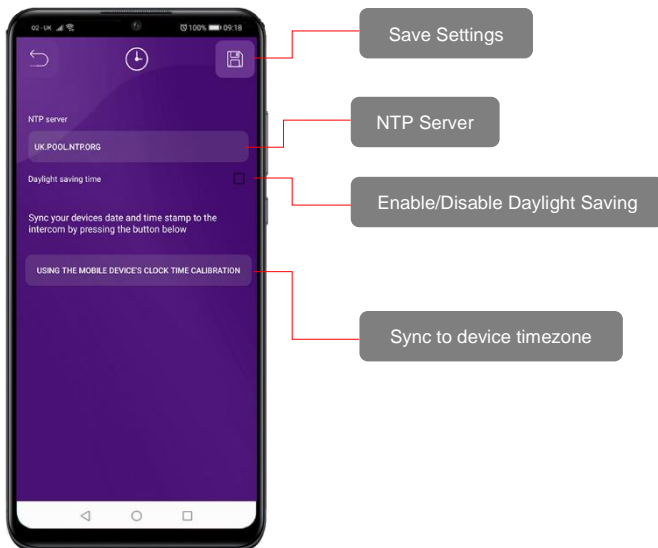

Wi-Fi Settings

*Only applicable if attempting to connect to WIFI directly.
Please follow our IP install manual for more details.

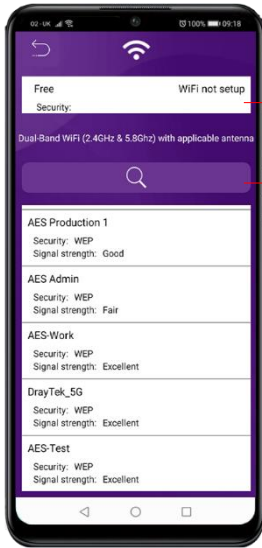

SSID currently connected to

Search for WiFi Networks.
See WiFi Setup for more details

Note: If showing POOR signal level, STOP!
You must reposition the antenna or look at alternative options to connect the intercom to the network.

Adjust Maximum Monitoring Time

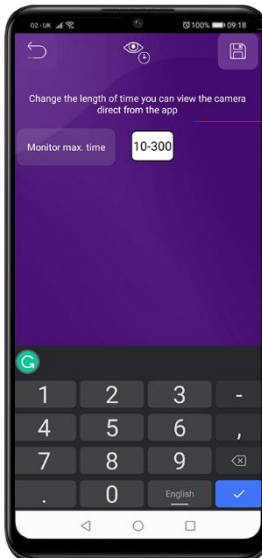

Save Settings

Change the length of time you can view the camera direct from the app

Adjust Maximum Talking Time



Save Settings

Change the length of time you can talk when a call is answered before the call disconnects.

Adjust Maximum Calling Time

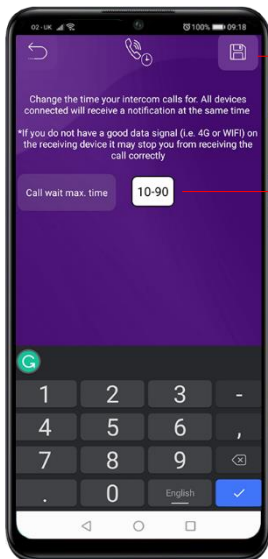

Save Settings

Change the length of time your intercom calls for.

Note: If you do not have a good data signal (i.e. 4G or WIFI) on the receiving device it may stop you from receiving the call correctly.

Note: All devices connected will receive a notification at the same time.

Reboot Intercom

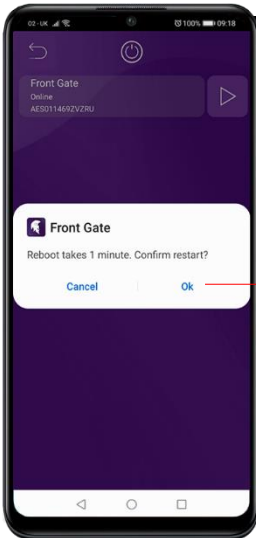

Soft Reboot the intercom

Simplex / Duplex Audio Selection

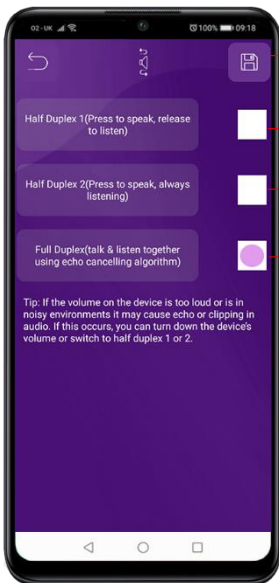

Save Settings

Soft Reboot the intercom

Soft Reboot the intercom

Soft Reboot the intercom

Note: If the volume on the device is too high or is in a noisy environment, it may cause echo or clipping in audio. If this occurs, you can turn down the device's volume or switch to one of the simplex audio options.

Advanced Feature Overview

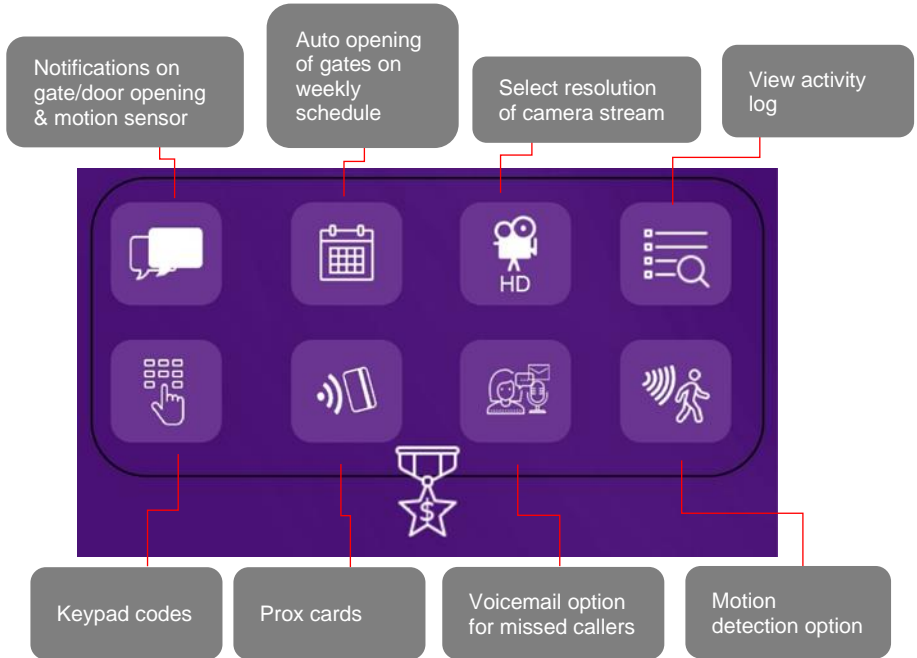

Notifications

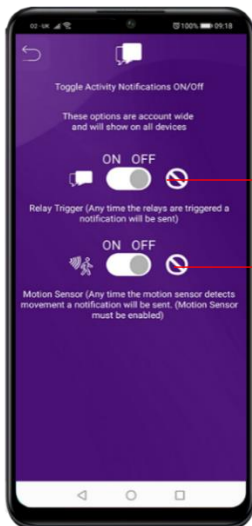

Enable/Disable app push notifications.
(Default = OFF)

Relay Trigger – Anytime the relay is triggered a notification will be sent.

This will affect PROX ID's, Keypad Codes & In-App Relay triggers.
Relay 1 = Entrance 1
Relay 2 = Entrance 2

Motion Sensor – Anytime the motion sensor detects movement a notification will be sent.

Note: Motion Sensor feature needs **Enabled** too for this to work as expected. See Motion Sensor Settings.

Auto opening of gates on weekly schedule

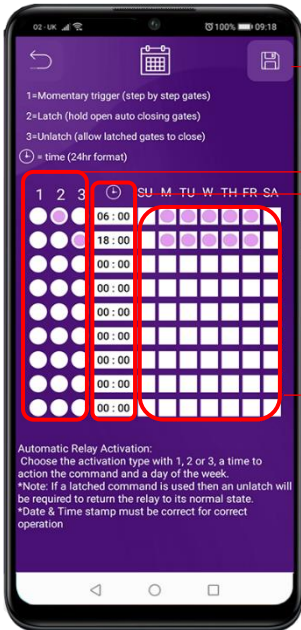

Save Settings

Relay Action

Time of Action

Day(s) for relay action to happen

Note: If a latched command is used then an unlatch will be required to return the relay to its normal state.

Date & Time settings of the intercom must be accurate for correct operation.

Select resolution of camera stream



Choose what resolution to use when your device is connected to WIFI & 4G.

Note: Data charges may apply if you exceed your personal allowance.

Activity Log

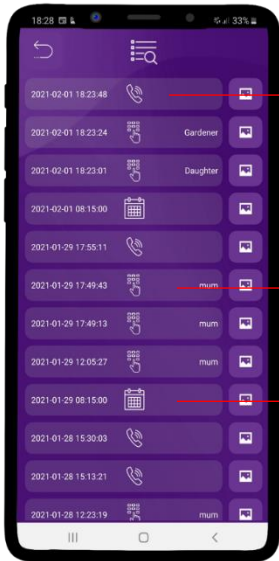

The log shows the most recent events which have occurred on the intercom. Some examples are shown. Some of the events capture images, or video from calls and can be played back by pressing the icons to the right.

Call received.

Keypad code entered.

Timed auto open event.

Note: SD card must be inserted into the slot on the PCB for this feature to operate correctly.

The log will show the last 100 events. Older events can still be retrieved via a microSD reader.

See page 10 for the SD card specifications.

Auto Reboot

This feature makes the intercom reboot every day at midnight. This feature comes enabled by default but can be disabled if you are having offline issues



Enable/Disable Auto reboot feature

Note: We recommend for optimum performance that you keep this feature enabled.

Keypad Codes

*Keypad models only



There are 3 types of keypad code options which can be entered as shown.

1. 24/7 codes which work all of the time. **(max 100)**
2. Time restricted codes which only work on pre-set times and days. **(max 100)**
3. Auto Expire codes which are temporary. **(max 100)**

Note: Press the * button to confirm the keypad code after entering it.

1. 24/7 Codes (max 100)

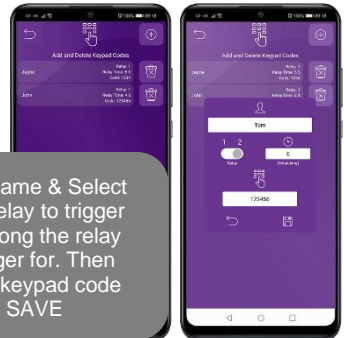

Enter Name & Select which relay to trigger & how long the relay will trigger for. Then enter a keypad code & press SAVE

2. Time Restricted Codes (max 100)

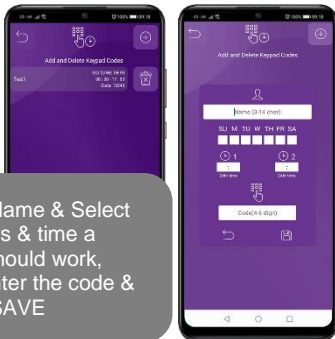

Enter Name & Select the days & time a code should work, then enter the code & press SAVE

3. Auto Expire Codes (max 100)

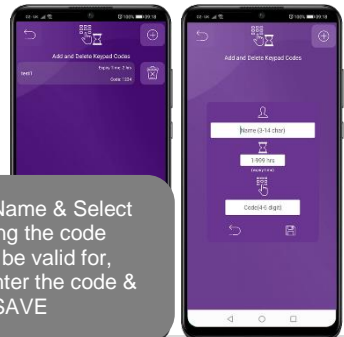

Enter Name & Select how long the code should be valid for, then enter the code & press SAVE

Note: Time Restricted & Auto-Expire options are only available for Relay 1. The relay time is controlled via the main relay settings.

24/7 options have a relay time specific to each code.

PROX Cards/Tag IDs

*PROX models only



There are 3 types of PROX ID options which can be entered as shown.

- 24/7 ID's which work all of the time. **(max 100)**
- Time restricted ID's which only work on pre-set times and days. **(max 100)**
- Auto Expire ID's which are temporary. **(max 100)**

1. 24/7 ID's (max 100)

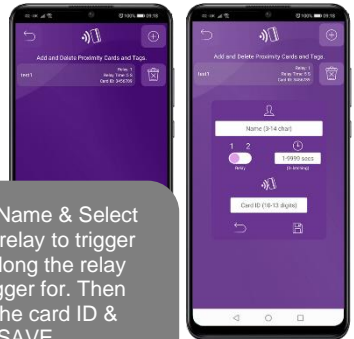

Enter Name & Select which relay to trigger & how long the relay will trigger for. Then enter the card ID & press SAVE

2. Time Restricted ID's (max 100)

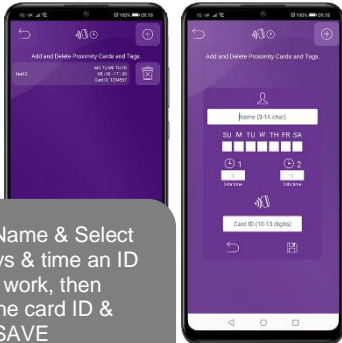

Enter Name & Select the days & time an ID should work, then enter the card ID & press SAVE

Note: Time Restricted & Auto-Expire options are only available for Relay 1. The relay time is controlled via the main relay settings.

24/7 options have a relay time specific to each code.

3. Auto Expire ID's (max 100)

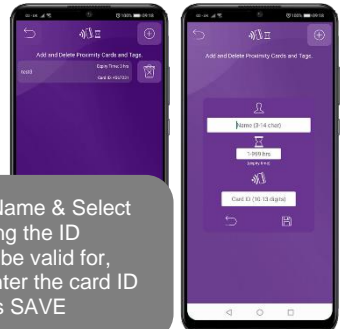

Enter Name & Select how long the ID should be valid for, then enter the card ID & press SAVE

Voicemail option for missed callers



When voicemail is activated if a call is not answered then an audio message will play to ask the visitor to leave a message. A 20 second video recording can be viewed in the events log.

Enable/Disable Voicemail feature

Note: SD card must be inserted into the slot on the PCB for this feature to operate correctly.

The log will show the last 100 events. Older events can still be retrieved via a microSD reader.

Motion Detection Option

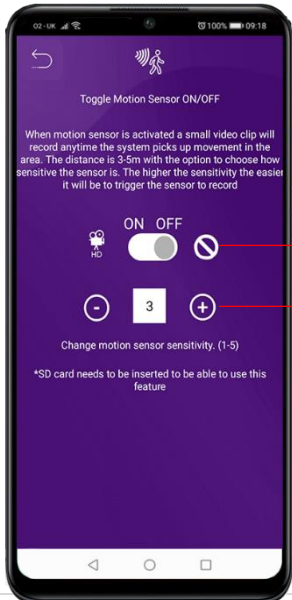

When motion sensor is activated a small video clip will record anytime the system picks up movement in the area.

The distance is fixed at max 5m with the option to choose how sensitive the sensor is. The higher the sensitivity the easier it will be to trigger the sensor to record.

Enable/Disable Voicemail feature

Change sensor sensitivity

Troubleshooting

It is worth remembering that when you install this intercom, you are literally only supplying 25% of the overall system. The other 75% already exists with the customer. Namely the router, the Wi-Fi network, and the phones or devices.

Anything can go wrong with any part of that entire system. Therefore, it is a useful exercise to attempt to prove to the customer that the intercom hardware is working and operational before attempting to diagnose the root cause, especially when connected wirelessly to a network.

If the intercom is connected via Wi-Fi to the network, it is very useful to press and hold the code button on the board, then connect the phone DIRECTLY to the BELL Wi-Fi network (must be within Wi-Fi range of intercom). Open the app and show the customer that when the phone is connected directly to the intercom, there is video and two-way speech. The job is then to find out what part of the installation or overall system is causing the problem since the intercom hardware has been proven as operational.

We can say without doubt that when we do get hardware failures, the above process will not work, and you will not get video and voice to the phone in a direct connection like this.

Below are the most common causes of problems with installs, starting with the most common first.

Symptoms caused	Problem/error	Solution
App showing offline status, video image shows "fetching, long lag on calls, intermittently showing online/offline, delayed push notifications.	4G Router Signal / APN Settings	Connect to the 4G router via LAN cable and test if you can load a web page. If not check the signal levels and APN settings to ensure they match the SIM network.
Delayed push notifications, video lag, voice problems, freezing, relays not opening the gate.	Wrong power cable (too thin) installed from 24v adaptor to the intercom, or power adaptor too far from intercom.	Change the power cable to specifications shown within this manual.
Lagging video or audio, delayed notifications, status showing intermittently online/offline, no or randomly operation of push notifications.	Poor GSM signal	Reboot the router and then try again. Connect to the 4G router via LAN cable and check the signal level. If low check with the coverage via the network providers website.
Can randomly display status "id already in use"	Additional user added incorrectly.	When an additional user was being added, the process was done incorrectly. Additional users MUST be added by the admin device first, with separate usernames created for each. The new usernames and passwords must be used by the new devices as shown in this manual to logon to the intercom.
App shows online when phone is in the same network but offline when phone on 3G/4G or on a	Commercial firewall	This will be a job for the IT provider for the business. A port will need opened to allow P2P

<p>remote Wi-Fi network, App works fine remotely to view gates but push notifications are not working at all.</p>		<p>and PUSH notification traffic to pass through the firewall. Recommended unassigned ports which your network administrator can open are 6806, 6809 and 9123, 9124.</p>
<p>App shows online status locally and when phone is remote, but push notifications may be delayed, or video lag, or showing “fetching” on video screen.</p>	<p>Insufficient upload speed / Poor GSM Signal</p>	<p>Reboot the router and then try again. Connect to the 4G router via LAN cable and check the signal level. If low check with the coverage via the network providers website.</p>
<p>Intercom is online and working even through the application, but I am receiving no notifications even for calls! I have checked my Wi-Fi/Ethernet and the intercom meets minimum requirements</p>	<p>Incorrect time setting on the Intercom.</p>	<p>Cycle to the settings menu and navigate to the clock settings and press “sync phone time” to sync the current time from the cellphone. This should only ever need done once as the time is pulled from the server.</p>
<p>I think my intercom is not functioning correctly.</p>	<p>Firmware/software bug.</p>	<p>Firstly ensure there is no network or site related issues. To do this you can connect directly to the system hotspot while in proximity of the unit and if the system operates fine then the local network and/or site specific issues are causing the problem. If the same issue occurs then a soft reboot can be completed by cycling to the settings menu and navigate to the power icon, pressing this will initiate a soft reboot. This soft reboot will remove any open communications or potential non-functioning features to be re-enabled. If this issue persists a hard reset may need to be performed. Access inside the panel is required and this will delete all current data programmed to the intercom and remove any additional users etc. If this still does not fix the problem this this would suggest a hardware fault. Please contact technical support.</p>

App Updates

We will continually monitor the app's performance and will release updates to enhance the users experience and/or fix any issues that arise overtime. These updates will be available via the iOS app store or the Android Play store.

Firmware Updates

Firmware updates will be released to fix any bugs or to add additional features where possible throughout the products lifetime.

The most recent firmware version your system is using can be found by using the app

The most recent firmware version will be available via the manufacturer website along with details of any changes made. The updates will be sent to all devices when it is released and if your system is ONLINE at the time it will update with no interaction from the user.

If you find your intercom is on an older firmware and may have missed the automatic rollout you can contact the manufacturer technical support via phone or live chat who can perform the update manually via a remote desktop application.

Extra Resources

Find all our support resources on our website or scan the QR code below.



We are constantly working to produce the highest quality documentation for our products. We welcome your feedback. Send us your comments or suggestions about our online Help, printed, or PDF manuals.

Please include the following information with your feedback:

- Product name and version number
- Type of document: printed manual, PDF, or online Help
- Topic title (for online Help) or page number (for printed or PDF manuals)
- Brief description of content (for example, step-by-step instructions that are inaccurate, information that requires clarification, areas where more detail is needed, and so on)
- Suggestions for how to correct or improve the documentation

We also welcome your suggestions for additional topics you would like to see covered in the documentation.

Send email feedback to: docfeedback@aesglobalonline.com

Please keep in mind that this email address is only for documentation feedback and will not be responded to unless we require more details. If you have a technical question, please contact the technical department.

Intercom Maintenance

Bug ingress is a common issue in unit failures. Ensure that all components are sealed accordingly and check occasionally. **(Do not open the panel in the rain / snow unless correctly equipped to keep the internals dry. Ensure the unit is securely closed after maintenance)**



We recommend sealing all entry holes for prevention of insects that can cause issues with a risk of shorting out components.



To maintain the IP55 rating please follow the sealing instructions included. (also available online)

If you have an AB, AS, ABK, ASK callpoint it will have silver edges which are marine grade stainless steel so in normal weather conditions should not rust however it can dull or discolor over time. This can be polished with a suitable stainless-steel cleaner and cloth.

4G Router Maintenance

If using a pre-pay casual SIM card it will need topped up occasionally. It is recommended to register the SIM card on the provider's web site if available. Most major networks allow registration of card payment details for an auto top up feature, which means they will automatically top up your intercom when the balance runs low or in some cases, they offer a low balance reminder to be sent if they do not wish the auto top up feature.

Environmental Information

The equipment that you bought has required the extraction and use of natural resources for its production. It may contain hazardous substances for the environment. In order to avoid the dissemination of those substances in our environment and to diminish the pressure on the natural resources, we encourage you to use the appropriate take-back systems. Those systems will reuse or recycle most of the materials of your end-of-life equipment.

The crossed-bin symbol marked in your device invites you to use those systems.



If you need more information on the collection, reuse and recycling systems, please contact your local or regional waste administration. You can also contact AES Global Ltd for more information on the environmental performances of our products.

Warranty

Please note, by installing this product, you are accepting the following warranty terms:

1. The manufacturer's warranty is a "return to base" 2 year warranty from date of manufacture. This means that any suspected defective components or items are returned to the manufacturer's agent for investigation and diagnosis and returned at the cost of the customer.
2. The warranty does not cover, nor is the manufacturer or agent responsible for any of the following whatsoever: Storm damage, lightning or surge damage, flooding, accidental damage, vandalism or deliberate damage, un-explained corrosion or unusually harsh environments, failure of telephone networks, future un-interoperability between the product and network providers which cause mal-function due to changes implemented by the phone providers after manufacture of the product, or that which is outside of control of the manufacturer (e.g. 2G, 3G switch off, removal or inability to obtain VOLTE service), and damage due to not proper installation.
3. The manufacture in no way accepts liability for any of the following incurred due to a product defect: Cost of attending site, inconveniences, labour rates, time lost, loss to or damage to property, security breaches, late payment clauses or breaches of any contracts between the installer and the client.
4. This is a profession install product only. The product is a component of an overall system. Therefore, it is the responsibility of the installer to certify the safety and compliance of the overall finished system. As soon as this product is fixed to another item, or connected to another third-party device, then the product has been modified, and compliance with local regulations in the country of install is strictly the responsibility of the installer.
5. Re-stocking fees may apply to items returned that are found to be non-defective. Complete units will also attract a re-stocking fee if returned for credit, regardless if a defect is discovered or not. Re-stocking fees may vary depending on the condition of the item being returned, and whether it can be determined as in brand new condition. The warranty terms do not entitle customers to an automatic full refund. For more details on returns procedures and re-stocking fees, contact the agent.
6. Items with physical signs of surge damage are not covered by warranty. Items with visible signs of surge damage will only be covered by warranty if photographic evidence is provided from site, showing surge protection has been installed, as per instructions in the full manual.

Full warranty terms and conditions available upon request to AES Technical Department.

Free Extra 1 Year Warranty



If you register with us within 90 days of purchase and provide proof of purchase, you will be eligible for an extra year of warranty.



SCAN ME

This QR code will take you to the warranty section of our website. You can access the form for the warranty by scrolling to the bottom of the section and pressing the “Extra year warranty” button.

****Only available in selected countries****

**LEFT
BLANK**

**LEFT
BLANK**

**LEFT
BLANK**

EU-RED Declaration of Conformity

FCC ID: 2ALPX-WIFIIBK

Grantee: Advanced Electronic Solutions Global Ltd



This device complies with Part 15E of FCC rules. Operation is subject to the following two conditions:

- (1) this device may not cause harmful interference, and
- (2) this device must accept any interference received, including interference that may cause undesired operation. Output power listed is conducted.

This device must be installed to provide a separation distance of at least 20 cm from all persons and must not be co-located or operating in conjunction with any other antenna or transmitter.

End-users and installers must be provided with antenna installation instructions and transmitter operating conditions for satisfying RF exposure compliance. This device has 20MHz and 40 MHz bandwidth modes.

This product is not a complete product until fully installed. It is therefore considered a component part of an overall system. The installer is responsible to check that the end installation complies with local regulatory requirements. This equipment forms part of a "fixed installation"

NEED MORE ASSISTANCE?

+1 (321) 900 4599

The manufacturer cannot legally offer technical support to non-qualified gate or door installers. End users should employ the services of a professional installation company to commission or support this product!

