

ALL-O-MATIC



BLDC PRO 36V
HEAVY DUTY OPERATORS
INSTALLATION MANUAL



COMMERCIAL



INDUSTRIAL



SL-175DC PRO

SLIDE GATE OPERATOR



SW-375DC PRO

SWING GATE OPERATOR



EACH INCLUDE: Pre-Wired loop Detector Rack | 2 Safety Gate Signs | RED EYE photoeye

The Standard by Which all other Gate Operators are Measured.

SLIDERS | SWINGERS | OVERHEADS

Table of Contents

Safety and Introduction

- Safety Instructions 1–2
- UL 325 Class Types 3
- Operator Specifications 4

Installation

- SL-175DC PRO Concrete Pad Installation 5
- SL-175DC PRO Front & Rear Mount Installation 6-8
- SW-375DC PRO Concrete Pad Installation 9
- SW-375DC PRO Arm Layout and Installation 10-12
- Electrical Connection..... 13
- Wire Size Chart 14
- Gate Opening Direction & Travel Adjustment 15-16

Board Features & Clutch Adjustment

- Dip-Switch Functions 17
- Auto Close Timer Setting & Receiver Wiring 18
- Gate Force Adjustment 19
- Clutch Torque Adjustment 20
- Primary/Secondary Setup & Wiring 21
- Auxiliary Relay & Leaf Delay Setting 22

Accessory Installation

- Entrapment Protection Installation 23–27
- Ground Loop Layout 28-29
- Plug-in Detector Installation 30
- Accessory Wiring 31-32
- Solar Panel Wiring 33-34
- LED Diagnostics 35
- Technical Troubleshooting 36
- AUX Inputs Programming 37
- LCD Display Settings & Diagnostics 38–41

Emergency Release Instructions

- Manual Release – SL-175DC PRO 42

Warranty and Customer Record

- Warranty and Customer Record 43

IMPORTANT SAFETY INSTRUCTIONS

WARNING

TO REDUCE THE RISK OF **INJURY**:

READ AND FOLLOW ALL INSTALLATION INSTRUCTIONS.

Do not start installation until you have read and fully understand these directions. If there is something you do not understand, please call us.

General Safety

- **Never** let children operate or play with gate controls.
- Locate the control station:
 1. Within sight of the gate.
 2. At a minimum height of 5 feet, so small children cannot reach it.
- Install the enclosed **entrapment warning signs** next to the control station and in a prominent location.

Manual Release

- For operators equipped with a manual release:
 - o Instruct the end user on correct operation.
 - o Use the manual release only when the gate is not moving.
 - o It is advised that power be turned off before use.

Operation and Testing

- Always keep people and objects away from the gate.
- **No one should cross the path of a moving gate.**
- The gate operator must be **tested monthly**:
 - o The gate must reverse on contact with a rigid object, or
 - o Stop when an object activates the non-contact sensor(s).
- Always re-test the operator after adjusting the limits and/or force.
- Failure to properly adjust and re-test may cause **severe injury or death**.

Maintenance and Service

- Keep gate(s) properly maintained.
- Have a **qualified service technician**:
 - o Make repairs to gate hardware.
 - o Perform adjustments to the gate operator.
- This gate entrance/exit is for **vehicles only**. Pedestrians must use a separate entrance.
- There is nothing on a gate operator that can be easily repaired or adjusted without training. Call a **qualified gate service technician** who knows your gate operator.

SAVE THESE INSTRUCTIONS

IMPORTANT SAFETY INSTRUCTIONS (CONTINUED)

INSTALL THE GATE OPERATOR ONLY WHEN YOU HAVE READ THE FOLLOWING

BEFORE GATE OPERATOR INSTALLATION

- Confirm that the gate operator being installed is appropriate for the application.
- Confirm that the gate is designed and built according to the current published industry standards.
- Confirm that all appropriate safety features and safety accessory devices are being installed, including all entrapment protection devices.
- Make sure that the gate opens and closes freely (by hand) before installing the operator.
- Repair or replace worn or damaged gate hardware before installing the gate operator.
- Eliminate all gaps in the sliding gate below a 6 foot height that permits a 2 1/4" sphere to pass through any location. This includes the area of the adjacent fence covered when the gate is in the open position
- Eliminate all gaps in a swing gate below a 4 foot height that permits a 4" sphere to pass through any location. This includes the hinge area of the gate.
- Install a proper electrical ground to the gate operator.
- Controls intended for user activation must be located at least 6 feet away from any moving part of the gate, and where the user is prevented from reaching over, under, around, or through the gate to operate the controls.
- Outdoor or easily accessible controls shall have a security feature to prevent unauthorized use.
- The stop and/or reset button must be located in the line of sight of the gate. Activation of the operator reset control shall not cause the operator to move.
- Install a minimum of 2 warning signs, one on each side of the gate where they are easily visible.
- Take pictures of the installation.
- Test all safety features for proper function before placing the automatic vehicular gate in operation.

GATE OPERATOR INSTALLATION

- Operator must be disconnected from the power source before attempting any installation of accessories.
- Install gate operator according to the installation instructions in this manual.
- Adjust the operator clutch or load sensing device to the minimum force setting that will allow for reliable gate operation.
- Install the operator inside the fence line. Do not install the operator on the public side of the fence line.

MAINTENANCE

- Train owners/users on the basic functions and safety features of the gate system, including how to turn off the power and operate the manual disconnect feature.
- Leave safety instructions, product literature, installation manual, and maintenance manual with the owner or end user.
- Explain to the owner or end user the importance of routine service and operator testing on a monthly basis.

UL 325 CLASS TYPES AND OBSTRUCTION SENSING SYSTEMS

Each class must have (2) monitored entrapment protection devices in each entrapment zone to sense and react to obstructions within 2 seconds.

All-O-Matic's gate operators conform to the most rigid Class One.

UL 325 CLASS TYPES

CLASS ONE: RESIDENTIAL

- A vehicular gate operator intended for use in garages or parking areas associated with a residence of one to four single families.

CLASS TWO: COMMERCIAL OR GENERAL PUBLIC ACCESS

- A vehicular gate operator intended for use at a commercial location or building, such as a multi-family housing unit (five or more single family units), hotel, garages, retail stores, or other buildings accessible by or servicing the general public.

CLASS THREE: INDUSTRIAL OR LIMITED ACCESS

- A vehicular gate operator intended for use at an industrial location or building, such as a factory, loading dock area, or other locations not accessible by or intended to service the general public.

CLASS FOUR: RESTRICTED ACCESS

- A vehicular gate operator intended for use at a guarded industrial location or building, such as airport security areas or other restricted access locations not servicing the general public and where unauthorized access is prevented via supervision by security personnel.

THE SIX TYPES OF OBSTRUCTION SENSING SYSTEMS

TYPE A:

- Inherent entrapment protection system. This system must sense and initiate the reverse of the gate within 2 seconds of contact with a solid object.

TYPE B1:

- Non-contact sensor (photoelectric sensor or equivalent). This system shall, upon sensing an obstruction in the direction of the gate travel, reverse the gate within a maximum of 2 seconds.

TYPE B2:

- Contact sensor (edge device or equivalent). This system shall, upon sensing an obstruction in the direction of the gate travel, initiate the reversal of the gate within a maximum of 2 seconds.

TYPE C:

- Inherent force limiting, inherent adjustable clutch, or pressure relief valve.

TYPE D:

- Actuating device requiring continuous pressure to maintain opening or closing motion of the gate.



SPECIFICATIONS

	SL-175DC PRO	SW-375DC PRO
Max Gate Weight	8,000 lbs. (12" per second) 3,000 lbs. (24" per second)	5,000 lbs.
Max Gate Length	100 feet	30 feet
Warranty	5 year commercial	3 year commercial
Motor	36 VDC brushless motor	36 VDC brushless motor
Gate Speed	12" or 24" per second (specify when ordering)	Adjustable 14-27 seconds per 90° opening
Power Options	115/230/480 VAC single phase and 36 VDC solar panel	115/230/480 VAC single phase and 36 VDC solar panel
Duty Cycle	Continuous	Continuous
Temperature Range	-40° to 160°	-40° to 160°
Gearbox Ratio	30:1 with internal disconnect	Large gearbox - 30:1 Small gearbox - 10:1
Width X Length X Height	19.5" W X 20" L X 27.5" H	19" W X 31" L X 25" H
Shipping Weight	320 lbs.	435 lbs. + 110 lbs. arm and wrench
Emergency Release	Mechanical foot pedal release	5/8" bolt to remove arm
Belt Size	4L-370 (Ax35) x2	4L-230 (AX21)
Main Sprocket Size	40B18X1-3/8	60A45X5
Chain Size	50NP (30' included)	60NP
Gearbox Sprocket	N/A	Top: 60B23X1.5 Bottom: 50B18X1.125 and 50B20X7/8
Limit Shaft Sprocket	40B18X5/8	N/A
Breaker Requirement	20 amp dedicated	20 amp dedicated
Gearbox Pulley	2AK49 with 3/4" bore	5" with 5/8" bore
Motor Pulley	2AK30 with 5/8" bore	2" with 5/8" bore
UL Classes	II, III & IV	II, III & IV

SL-175DC PRO CONCRETE PAD

TOP VIEW

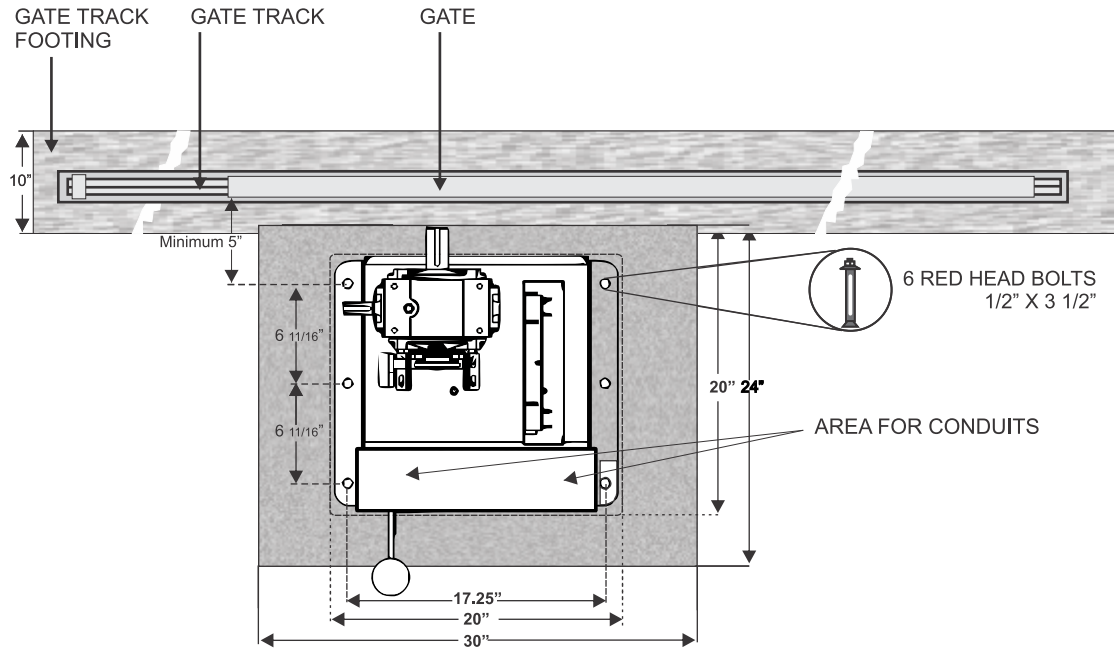

FRONT VIEW

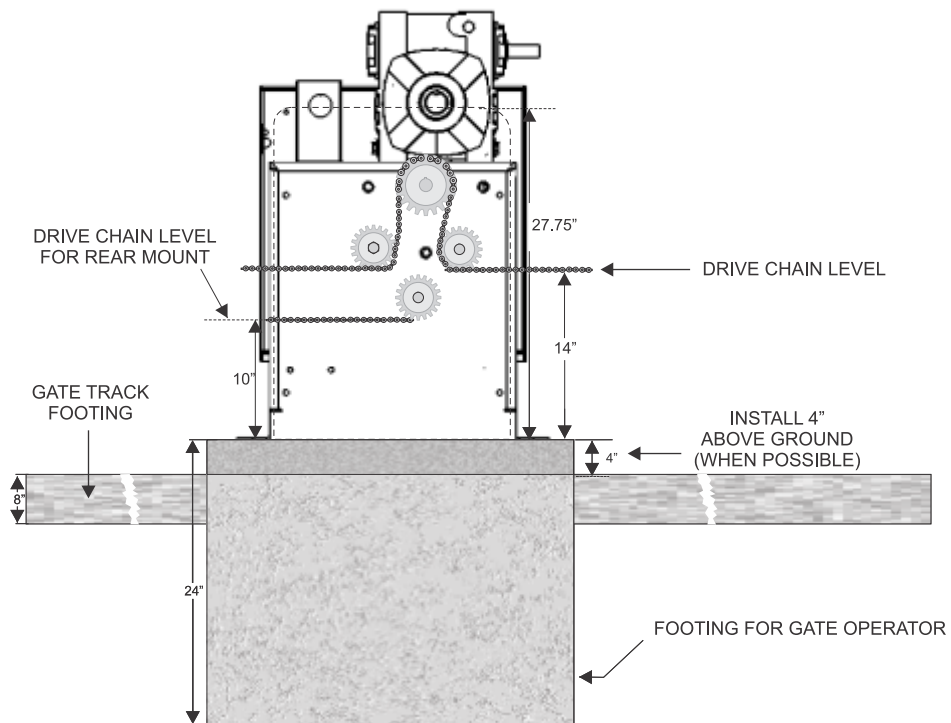

SL-175DC PRO FRONT MOUNT INSTALLATION

FRONT VIEW

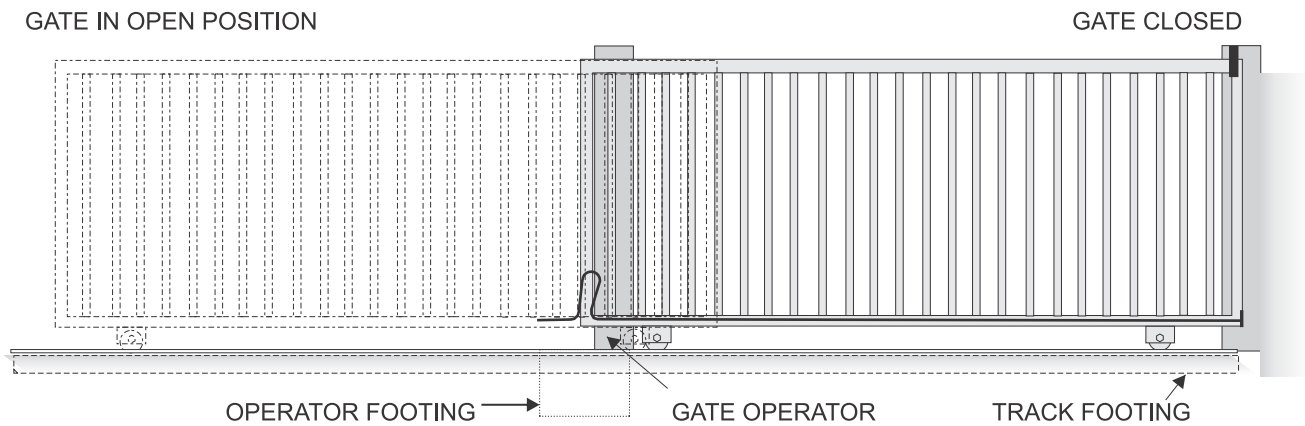

OVERHEAD VIEW

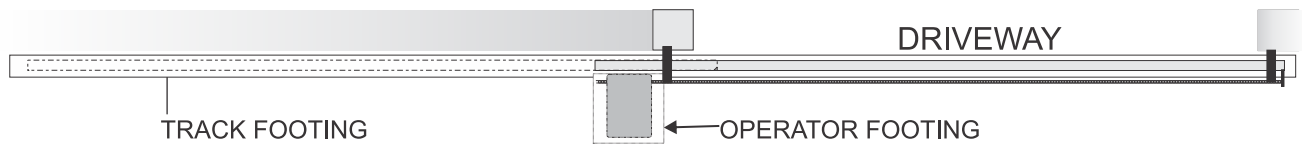

SL-175DC PRO FRONT MOUNT INSTALLATION (CONTINUED)

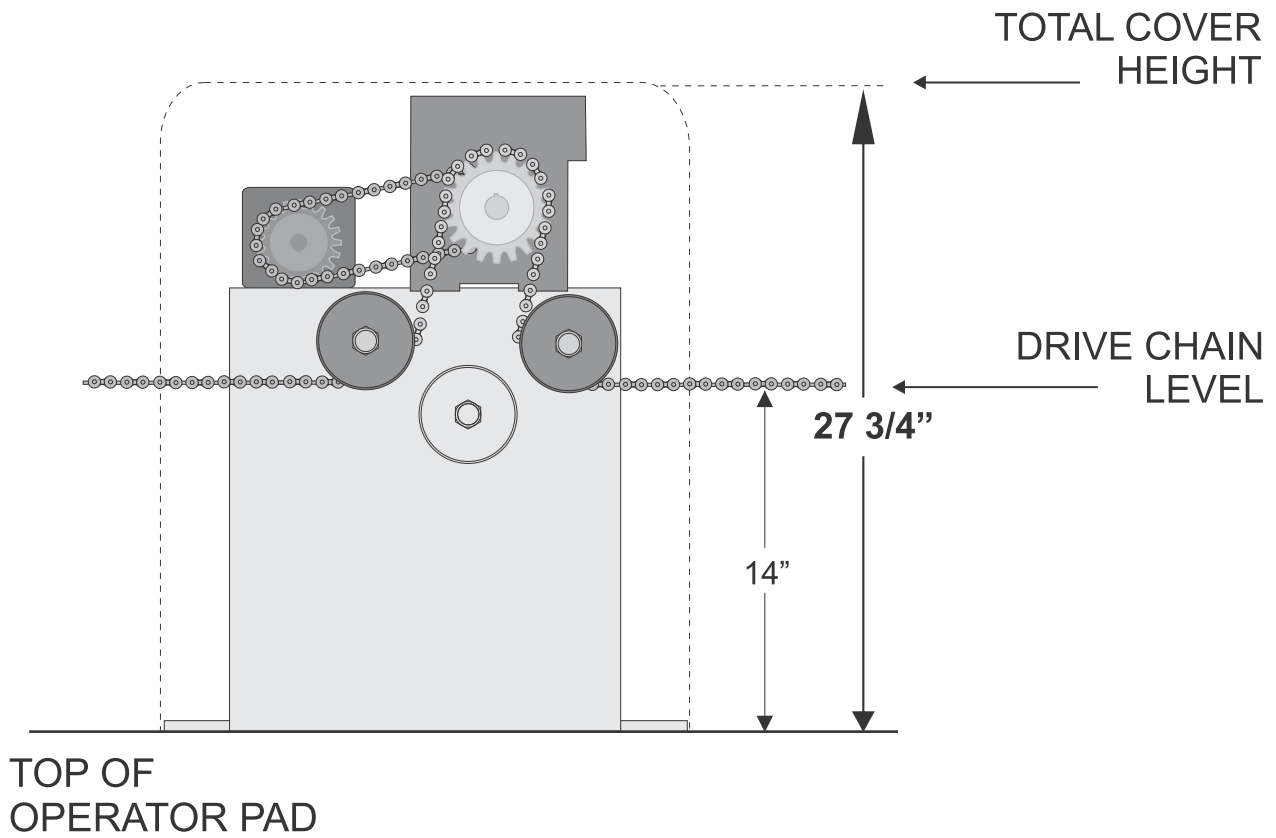

SL-175DC PRO REAR MOUNT INSTALLATION

FRONT VIEW

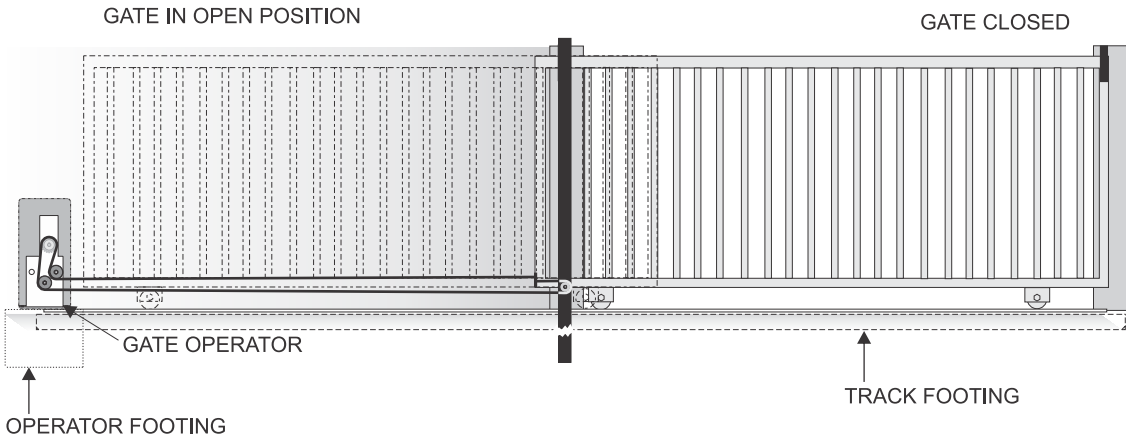

OVERHEAD VIEW

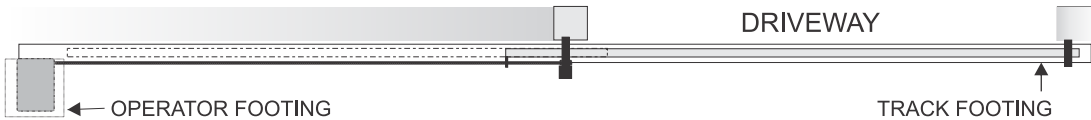

CHAIN CONNECTION TO GATE

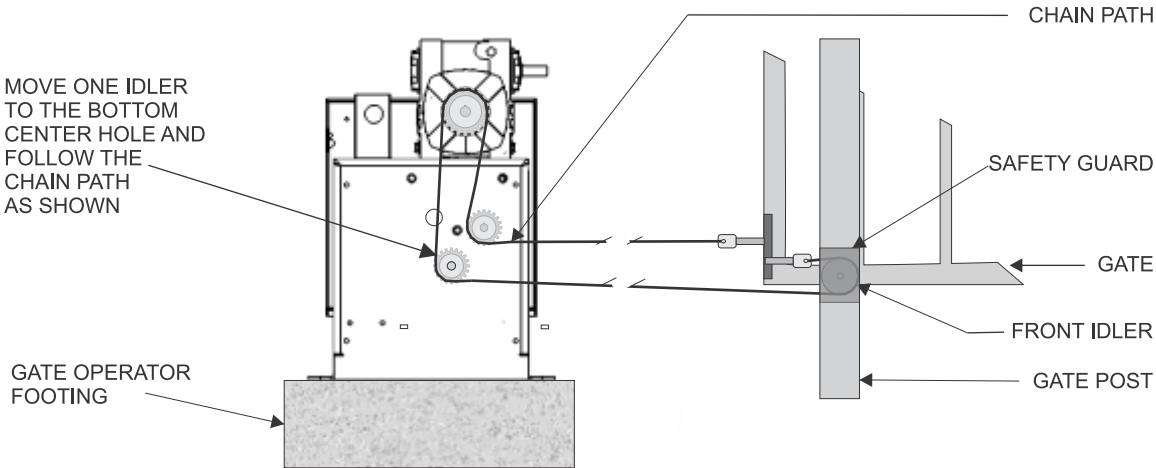

SW-375 DC OPERATOR AND ARM DIMENSIONS

Please refer to the chart and drawing below for operator and arm dimensions.

- A: The distance between the center of the gate bracket and the center of the hinge point.
- B: The distance between the gate hinge point and the edge of the operator concrete pad.
- C: The distance from the gate in the open position to the center of the operator shaft.
- D: The distance from the center of the gate hinge to the center of the operator shaft.
- Minimum distance: The minimum distance required behind an open gate and an obstruction (ie: wall, bush, etc).
If this distance is between 20" and 33", refer to the compact installation page.

SW-375 DC Dimensions Chart

Gate length	A	B	C	D	Minimum Distance
Less than 12'	36"	32"	13"	46"	34"
13'-15'	42"	38"	13"	52"	37"
16'-22'	48"	44"	13"	58"	40"

NOTE: The 2" distance shown above is from the gate in the open position (90 degrees) to the edge of the concrete pad. If the gate must open more than 90 degrees, the concrete pad and distance "C" need to move back accordingly. The distance between the open gate and the concrete pad needs to remain 2".

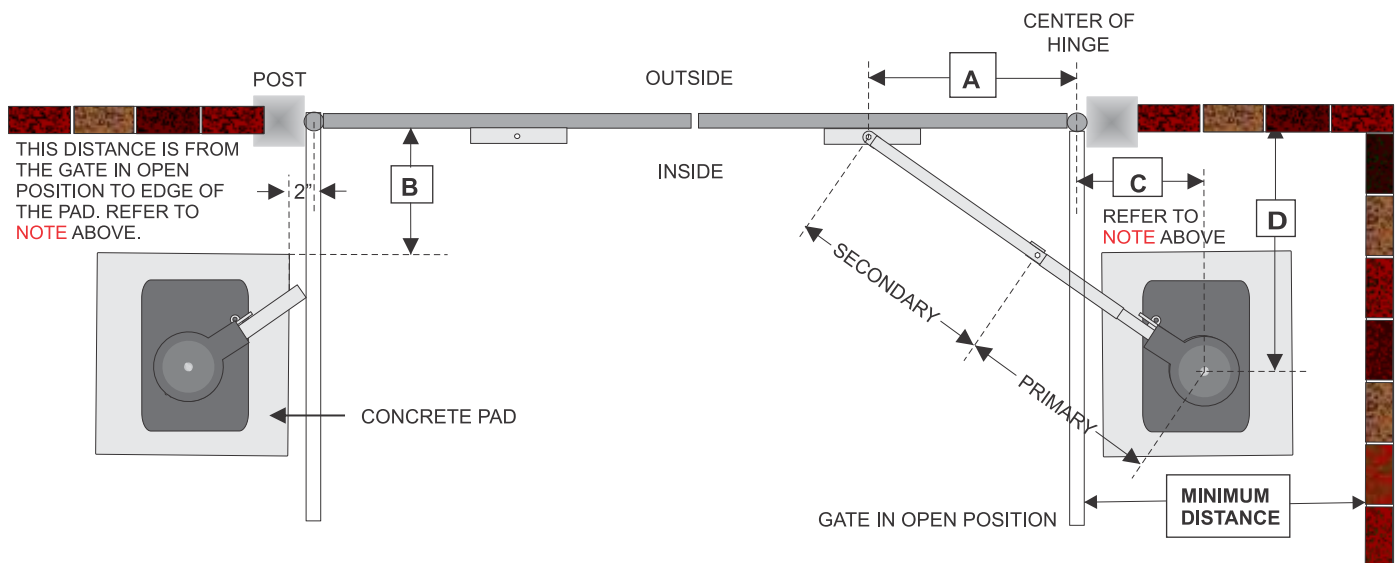

SW-375 DC OPERATOR PLACEMENT AND ARM LAYOUT (CONTINUED)

Step 3:

- Measure the distance between point **Y** and point **Z**. Divide this number in half.
- This number is length of the primary arm section in the next step.
- **Please be exact.**

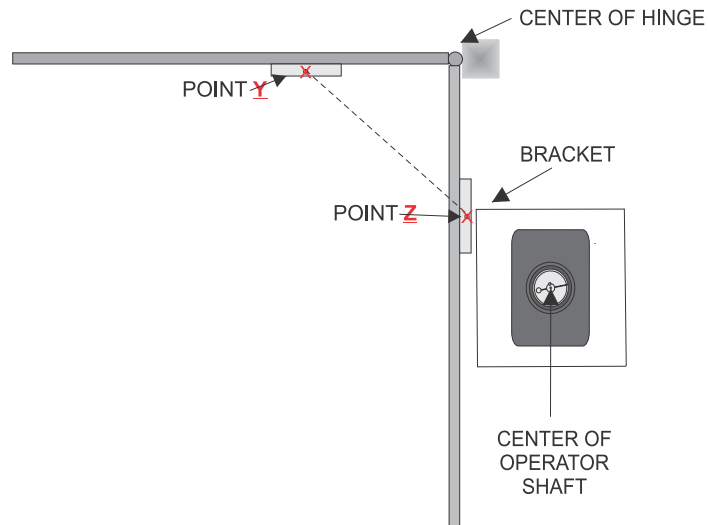

Step 4:

- Cut the primary arm section the measurement you recorded in Step 3 (half the distance between point **Y** and point **Z**).
- The secondary arm makes up the rest of the arm length to the gate bracket and does not need to be measured exactly.

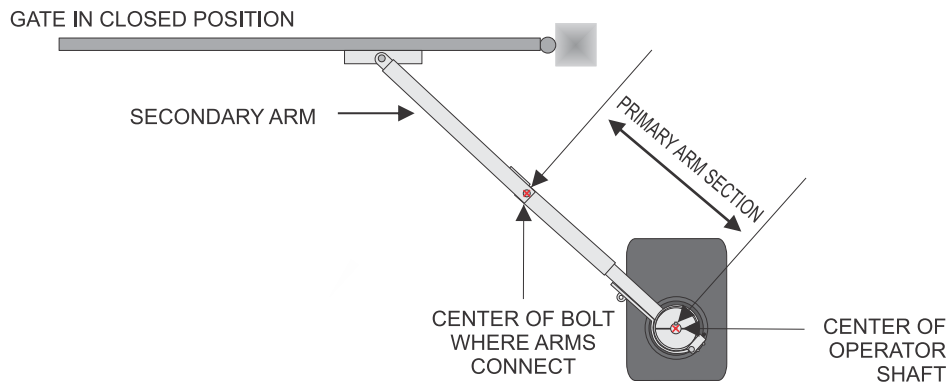

SW-375 DC OPERATOR PLACEMENT AND ARM LAYOUT

Step 1:

- With the gate in the closed position, mark the ground directly below the center of the gate bracket. This will be point **Y**.
- With the gate in the open position, mark the ground directly below the center of the gate bracket. This will be point **Z**.

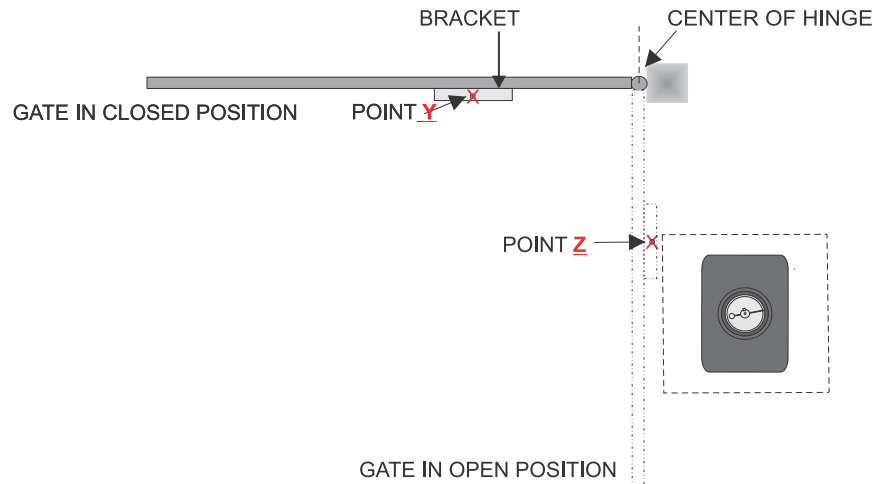

Step 2:

- Chalk out a line connecting point **Y** and going past point **Z** as shown in the drawing below.
- The center of the operator shaft goes on this line. Bolt down operator.

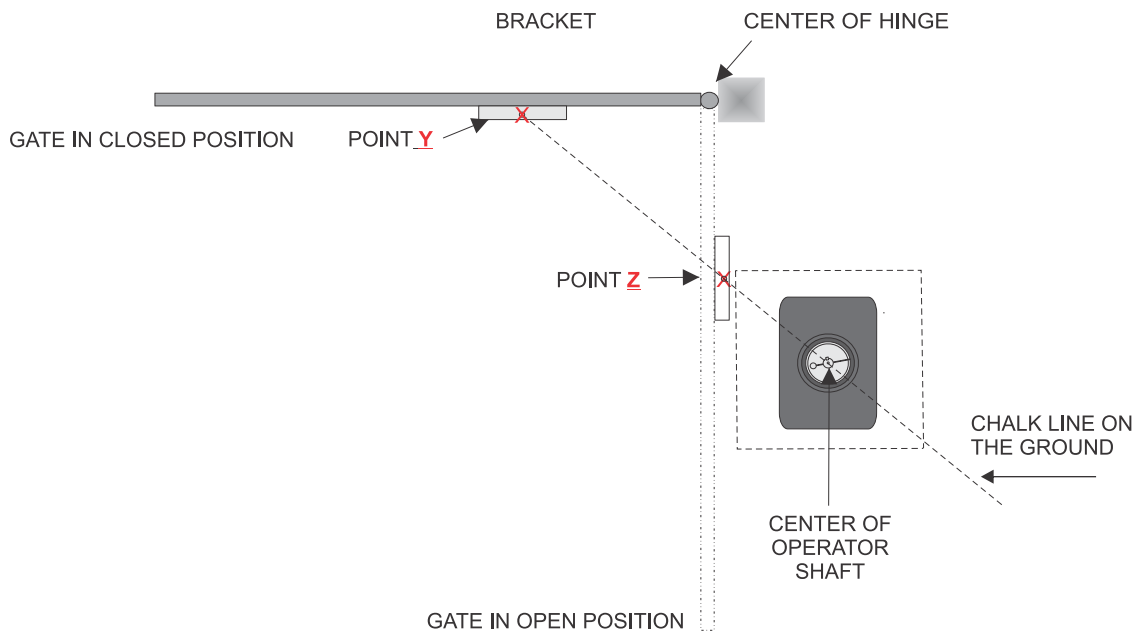

ELECTRICAL CONNECTION

⚡ OPERATORS MUST BE PROPERLY GROUNDED! ⚡

Grounding

- **All gate operators MUST be properly grounded.**
Proper grounding minimizes or prevents damage caused by electrical charges, such as lightning strikes or static discharge.
- Use a **single, continuous ground wire.**
 - **Do not splice** two wires together.
 - If the ground wire is cut or broken, replace it with a new single-length wire.
 - **Never use two separate wires** for the ground.
- Check local city code for:
 - Approved earth ground rod type.
 - Proper grounding procedures.
Correct grounding is critical for lightning protection on the control board.

Power Wiring

- Use **UL-listed conduit** for enclosing all power wires.
- Operators can be powered from **115VAC or 230VAC single phase.**
 - On the EMI board, use the **voltage selector switch** to match the correct voltage option.
 - Refer to the **wiring table** below for incoming power connections.
- Provide a **dedicated 20A minimum circuit** for each operator.
- Refer to the **current draw table** to determine the proper power wire size.

DC PRO Gate Operators	Current Draw @120VAC	Current Draw @208/240VAC
SL-175DC PRO	11 Amps	6 Amp
SW-375DC PRO	11 Amps	6 Amp

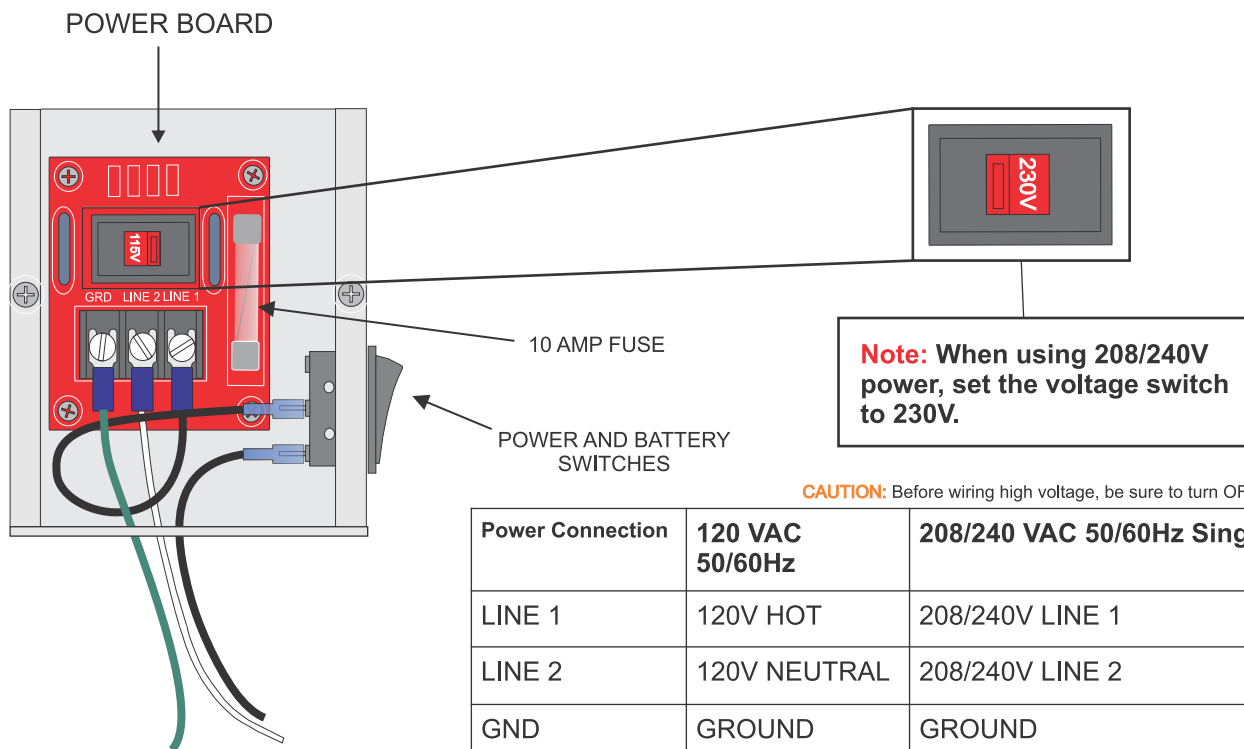

AC POWER ELECTRICAL WIRING (cont.)

Power Wire Sizing & Neutral Connection

Wire Sizing

Use the **operator current draw table** (previous page) along with the **wire size tables** (below) to calculate the correct power wire size for your installation.

 **It is critical to use the proper wire size** to avoid excessive voltage drop and ensure safe, reliable operation.

Important Neutral Connection Notice

Because these operators support **dual voltage (120VAC / 208/240VAC single phase)**, the receptacle neutral is handled differently:

- **120VAC Operation**
 - The **white receptacle neutral wire** must be connected to the **neutral wire of the EMI board**.
- **208/240VAC Operation**
 - **Do not connect** the receptacle white neutral wire.
 - Connecting it in this mode will cause damage to devices plugged into the receptacle.

Use below table to select the correct power wire size for the power run. It is important to use the correct size wire, as it is crucial to avoid voltage drops.

Max Wire Feet @ 120 Volts, 1 Phase, 2% Max Voltage Drop						
Operator model	Volt-Amps	#14	#12	#10	#8	#6
SL-175DC PRO	1200	50	75	120	180	280
SW-375DC PRO	1200	50	75	120	180	280

Max Wire Feet @ 208/240 Volts, 1 Phase, 2% Max Voltage Drop						
Operator model	Volt-Amps	#14	#22	#10	#8	#6
SL-175DC PRO	1200	100	150	240	375	575
SW-375DC PRO	1200	100	150	240	375	575

Gate Opening Direction



LED indicators will indicate opening or closing when the gate is in motion

Use the **OPEN L/R dip-switch (#8)** to change the operator's opening direction.

- The opening direction is determined **while standing behind the gate operator**.
- LEDs will display the **opening** and **closing** direction when the gate is moving.

Dip-Switch Settings

- **OPEN L/R OFF** – Left-hand opening
- **OPEN L/R ON** – Right-hand opening

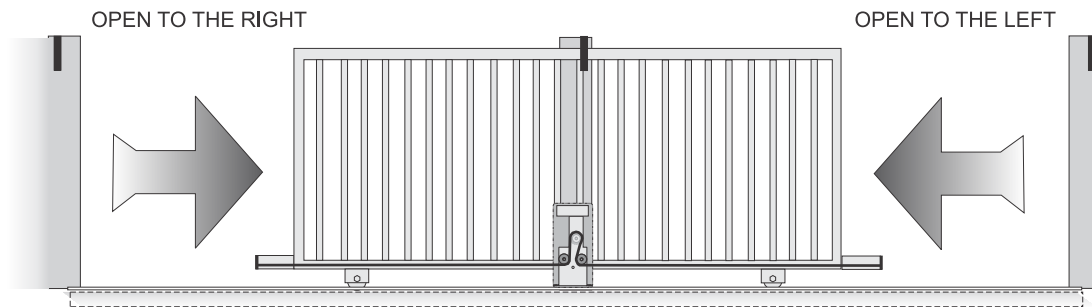

LIMIT TRAVEL ADJUSTMENT

Locate the limit switches (limit switches will be in the limit box on SL-150DC PRO) and follow the steps below:

- 1: Turn the power **OFF** on the operator.
- 2: Pull the limit lock plate outward (on the SL-175DC PRO)
- 3: Turn the limit nut toward the switch to **DECREASE** travel and away from the switch to **INCREASE** travel.
- 4: Place limit plate back to its locked position. (**MUST** be done for gate to hold its limits)
- 5: Turn the power **ON** to the operator.
- 6: Run the gate operator open and close. If additional adjustment is needed, repeat the steps.
- 7: When limits are set, move the gate to the closed position. Press and release "RESET" on the circuit board and run the gate one uninterrupted cycle (full open and full close) to learn the slow down.

SL-175DC PRO

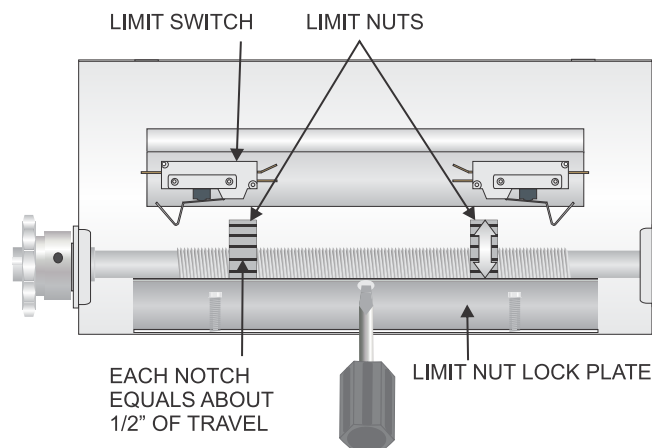

GATE DIRECTION ADJUSTMENT

- Use OPEN L/R” dipswitch (#8) to change the opening direction of the operator.
- The direction of gate opening is determined from behind the gate operator.
- LEDs will show opening and closing direction when the gate is moving.
- OPEN L/R switch “OFF” is for left hand opening
- OPEN L/R switch “ON” is for right hand opening

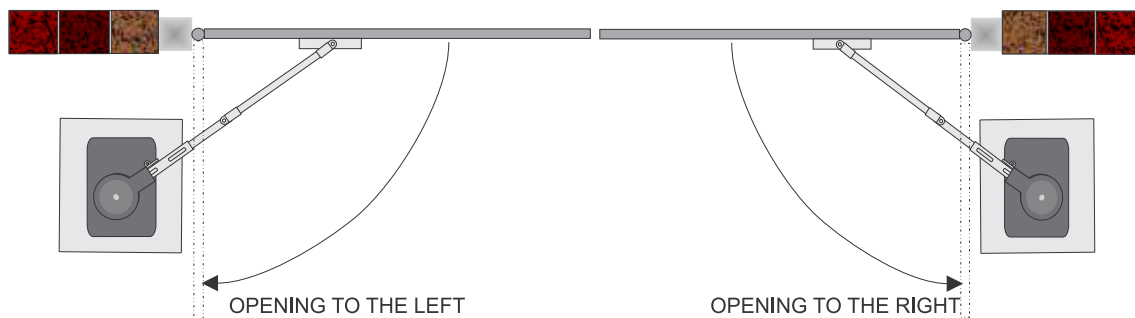
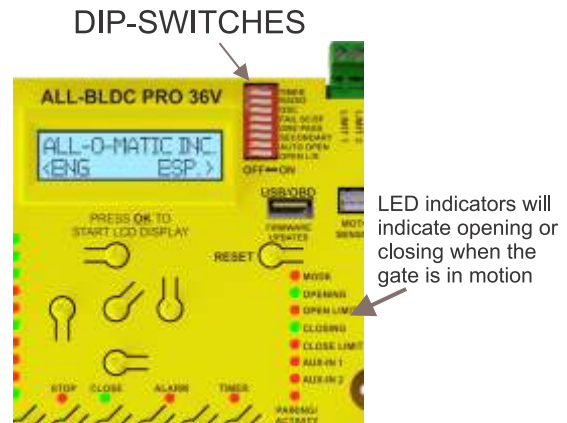

GATE TRAVEL ADJUSTMENT

After locating the limit switches and identifying which switch is for open and close, follow the steps below to adjust the gate travel:

1. Turn the power OFF on the gate operator.
2. Use a screwdriver to loosen up the limit cams and turn the limit cams in the desired direction.
3. Tighten the phillips screw.
4. Turn the power ON.
5. Run the gate operator.
6. Repeat the steps if more adjustment is required.
7. When limits are set, move the gate to the closed position. Press and release “RESET” on the circuit board and run the gate one uninterrupted cycle (full open and full close) to learn the slow down distance.

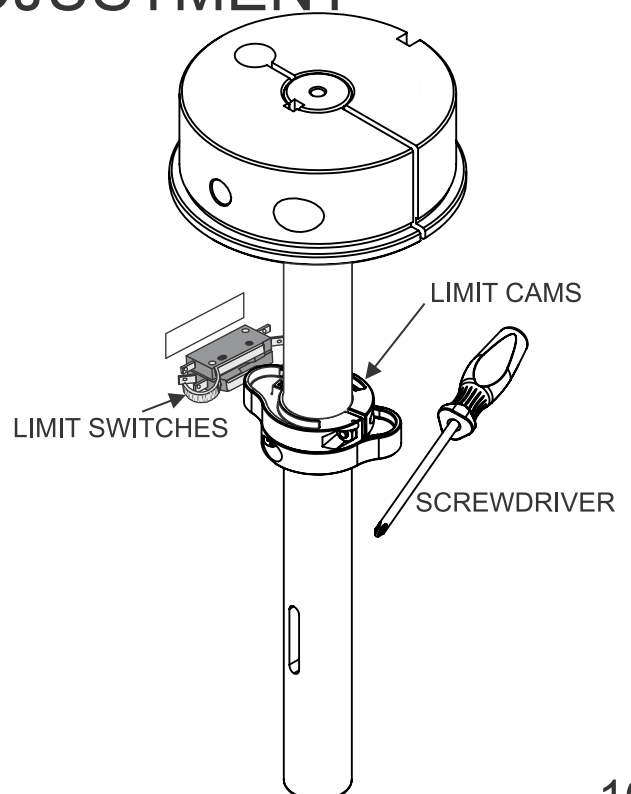

DIP-SWITCHES FUNCTION

TIMER

- **ON** – Activates the automatic close timer. (See *TIMER* page for details.)

RADIO

- **ON** – Allows the radio receiver to override the automatic close timer. (See *TIMER* page for details.)

OSC (Open/Stop/Close)

- **ON** – Allows the radio receiver to stop and reverse the gate at any point.
 - First signal: **Stops** the gate.
 - Second signal: **Reverses** the gate.

FAIL SC / SF

- **ON (Fail-Safe):** On power failure, the board monitors battery voltage to ensure the gate opens before the battery drains completely.
- **OFF (Fail-Secure):** On power failure, the gate runs until the battery is low, then locks closed.

1-PASS

- **ON** – Enables one-pass anti-tailgating using a safety loop.
 - Gate opens and immediately closes once vehicle clears Safety loop.
 - Gate stops if a second vehicle is detected. Waits until vehicle clears the Safety loop, then continues to close.
 - A second vehicle must present valid credentials before entry.

SECONDARY

- For **dual gate applications:**
 - **ON** – Set on the **secondary operator** only. (all other dip-switches OFF, except OPEN L/R).
 - **OFF** – Set on the **primary operator**

AUTO OPEN

- **ON** – Automatically opens the gate after a power interruption. (Required in some fire department jurisdictions.)
- Includes a **45-second delay** between power loss and gate opening.

OPEN L/R

- **ON** – Right-hand opening.
- **OFF** – Left-hand opening.

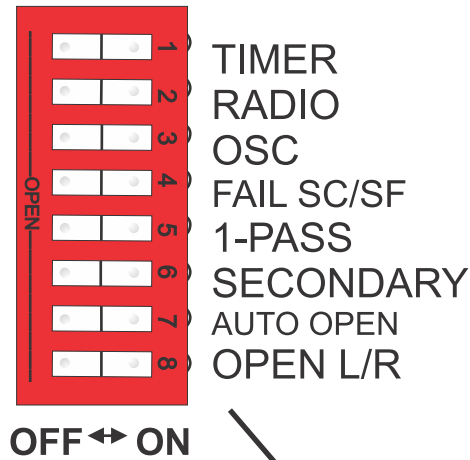

NOTE: After making any changes to the dip-switches, press the **MAIN RESET** button to apply and recognize the changes.

AUTO CLOSE TIMER SETTING AND RADIO RECEIVER CONNECTION

TIMER

- **ON** – Automatic close timer active. Adjustable **1–120 seconds (up to 2 minutes)**.
- **OFF** – Gate operates by command only: *Push button to open, push button to close.*

RADIO

- **ON** – Overrides the timer and allows the transmitter to close the gate before the auto-close timer expires.

OSC (Open/Stop/Close)

- **ON** – Remote/transmitter controls the gate like a garage door opener:
 1. Press once → Gate starts moving.
 2. Press again → Gate stops.
 3. Press a third time → Gate reverses.

Timer Adjustment Procedure

1. Set the **TIMER dip-switch** to **ON**.
2. Press the **TIMER push button** to open the **TIMER adjustment** in the LCD display.
3. Use the **UP/DOWN buttons** to set the number of seconds (1–120) the gate remains open before closing automatically.
4. Press **OK** to save the setting.

TIMER, RADIO & OSC dip-switches



TIMER quick access button

Radio Receiver Connections

There are **two types of receivers: 3-wire and 4-wire.**

3-Wire Receiver

- Mounts directly on the **radio receiver terminal strip** located outside of the control box.

4-Wire Receiver

- **Relay Contact Wires**
 - Connect to **Terminal 1 (COMMON)** and **Terminal 2 (RELAY/RADIO)** — one wire on each terminal.

Power Wires

- Connect **black (negative)** wire to **Terminal 1 (COMMON)**.
- Connect **red (positive)** wire to **Terminal 3 (+12/24VDC)**.

(See diagram below for reference.)

Related Dip-Switch

- **RADIO ON** – Allows the radio receiver to override the **automatic close timer**.
(See *TIMER adjustment* section above for details.)

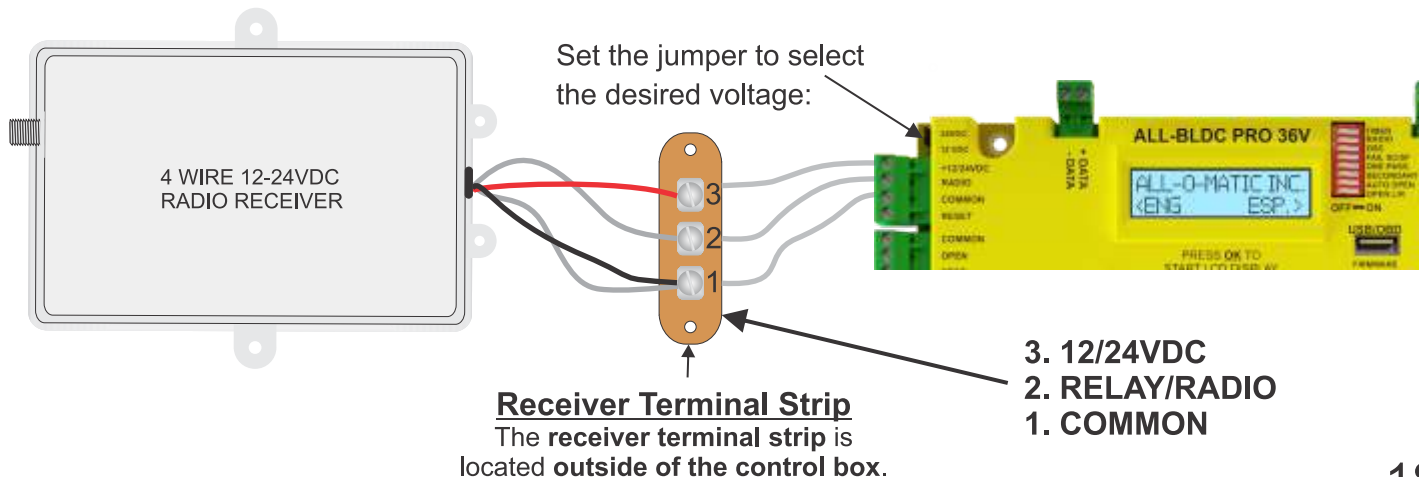

ELECTRONIC REVERSING DEVICE (ERD) ADJUSTMENT

Electronic Reversing Device (ERD)

All **BLDC PRO** boards are equipped with an **Electronic Reversing Device (ERD)**. This feature causes the gate to **reverse direction when it comes into contact with an obstruction**.

Force Setting

- The reversing force depends on the **ERD force setting**.
- If the gate **reverses without obstruction**, the ERD force is set **too low**.
- If the gate **does not reverse on obstruction**, the ERD force is set **too high**.

Safety Requirement

- ERDs **must be adjusted** for reliable and safe operation.
- A **qualified technician** shall test and adjust the ERDs **every six months**.

Adjustment Access

- Quick-access buttons are provided for **OPEN ERD** and **CLOSE ERD** adjustments.
- These open directly to the adjustment menu — no need to navigate through the LCD menus.

Adjustment Procedure

1. Adjust OPEN ERD

- While the gate is **opening**, press and release the **OPEN ERD** button.
- The **OPEN ERD adjustment** will appear on the LCD display.
- Use the **DOWN** button to decrease force until the gate stops and reverses.
- Increase the setting by **30% above that point**.
 - Example: If reversal occurred at **20%**, increase to **50%**.
 - This provides a buffer for reliable operation and safety.

2. Adjust CLOSE ERD

- While the gate is **closing**, press and release the **CLOSE ERD** button.
- The **CLOSE ERD adjustment** will appear on the LCD display.
- Use the **DOWN** button to decrease force until the gate stops and reverses.
- Increase the setting by **30% above that point**.
 - Example: If reversal occurred at **20%**, increase to **50%**.
 - This ensures reliable closing and obstruction response.

Factory Setting

- From the factory, **OPEN ERD** and **CLOSE ERD** are set to **50%**.



ERD quick access buttons

Torque Limiter Adjustment

Tools Required

- 3/4 in. wrench

Procedure

1. The torque limiter is shipped loose and must be adjusted during installation.
2. Use a 3/4 in. wrench to tighten the three torque limiter bolts.
3. Turn **each bolt 1/2 turn at a time**, alternating between bolts to keep pressure even on the spring washers.
4. Continue tightening until the **clutch does not slip** during normal operator run.
5. Test the setting by running the gate and applying resistance by hand to confirm the **torque limiter does slip** under load.
6. Readjust in small, equal increments if needed.

Important

This is a critical adjustment. Ensure it is completed correctly before placing the operator into service.

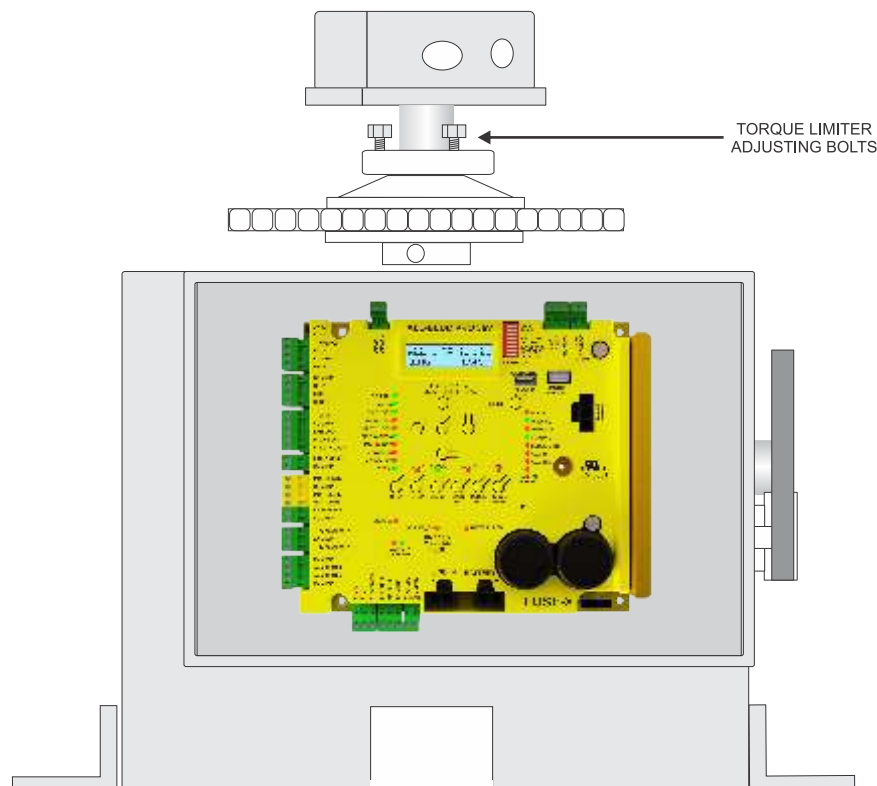

Primary/Secondary Communication Setup

⚠ Important: Complete these steps **before linking Primary/Secondary communication.**

Preparation

1. **Adjust the ERDs and limit switches** on each operator individually as stand-alone machines. (See *ERD and Limit Switch Adjustment* sections for details.)
2. On the **secondary controller**:
 - o Set the **SECONDARY dip-switch to ON.**
 - o Press the **RESET** button.

The **ALL-BLDC PRO controller** supports two types of Primary/Secondary communication: **Wireless** and **Hard-Wired**. Accessories can be connected to **either the Primary or Secondary operator.**

Wireless Setup

1. On the first operator:
 - o Press and hold the **UP** button.
 - o While holding, press and release the **RESET** button.
 - o Continue holding **UP** until the LCD displays:
 - § A message prompting to **SETUP the other unit**, and
 - § The default channel (**Channel 1**).
 - o Release the **UP** button.

2. Repeat step 1 on the **second operator**.
 - o Confirm both units display the **same channel.**
 - o Ensure the **SECONDARY dip-switch is ON** for the secondary operator.
3. Once both units show the same channel and correct dip-switch settings, the operators will link.
 - o The **P/S LINK LED** will turn **ON.**

Hard-Wired Setup

1. On the first operator:
 - o Press and hold the **DOWN** button.
 - o While holding, press and release the **RESET** button.
 - o Continue holding **DOWN** until the LCD displays **WIRED MODE.**
2. Repeat step 1 on the **second operator**.
 - o Ensure the **SECONDARY dip-switch is ON** for the secondary operator.
3. Wire the two operators according to the diagram:
 - o Connect **DATA+ to DATA+** and **DATA- to DATA-.**
4. After wiring is complete, the operators will link.
 - o The **P/S LINK LED** will turn **ON.**

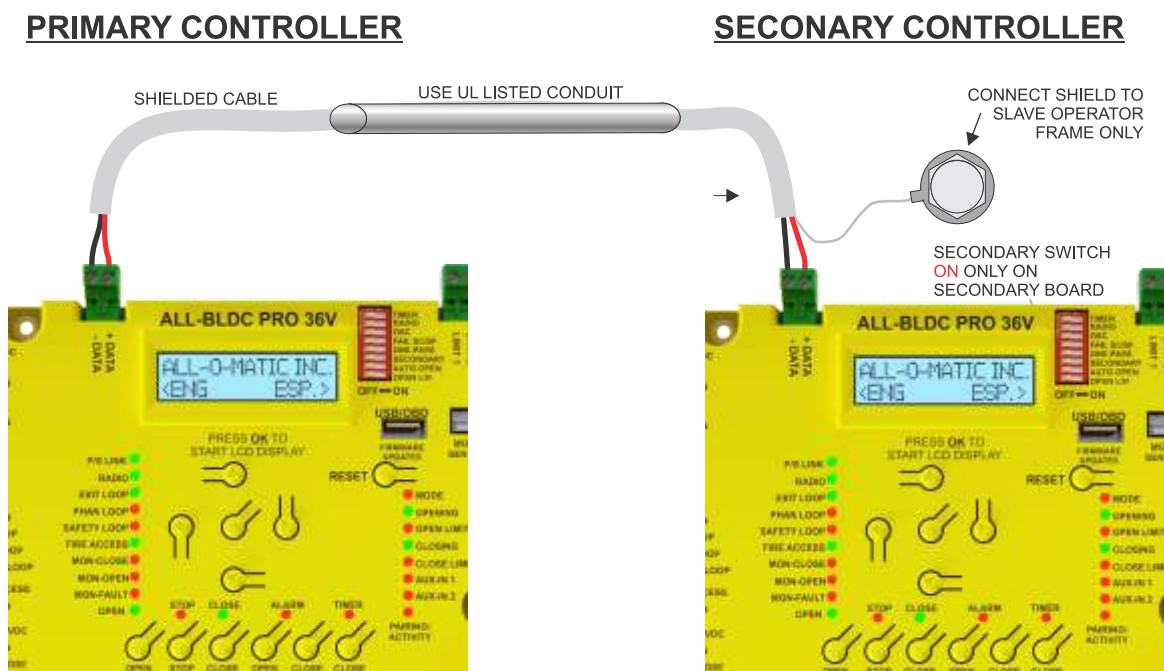

Relay Programming and Gate Leaf Delay

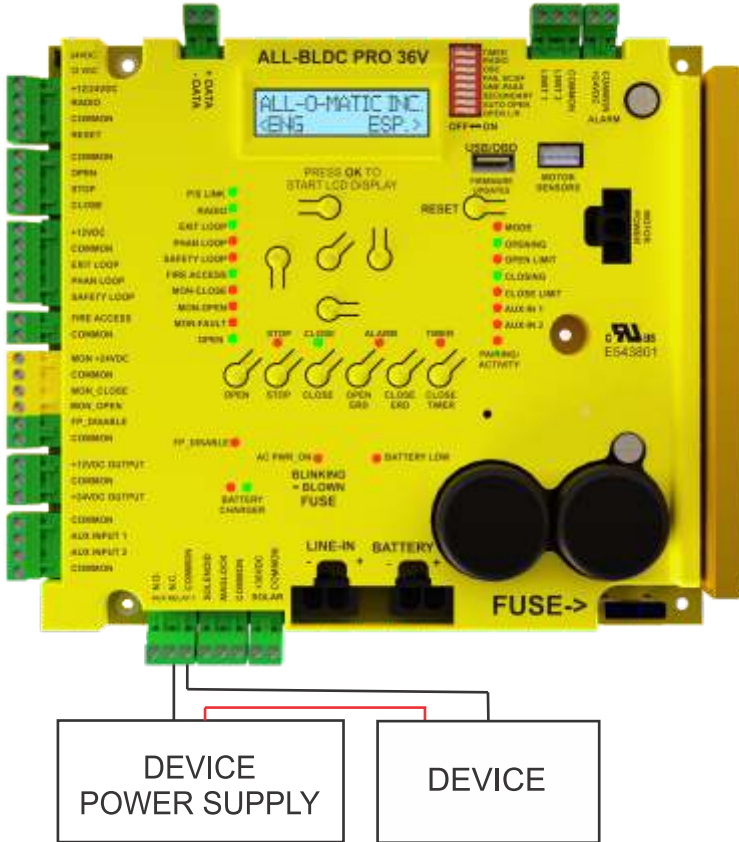

Entering the LCD Display Menu

1. **Wake the Display** – Press the OK button twice.
 - o A startup message will appear on the screen.
2. **Select Language** – Press the LEFT button to start the English menu.
3. **Access Settings** – Highlight **SETTINGS** and press OK.
 - o Here you will find options such as **AUXILIARY RELAY** and **LEAF DELAY**.

Navigation Controls

- **UP/DOWN buttons** – Scroll through menu items.
- **LEFT button** – Return to the previous menu.

Relay-1 Settings

The **ALL-BLDC PRO** includes a programmable relay (N.O. or N.C.) with four configurable options.

Navigation

From the LCD menu:

English → **SETTINGS** → **AUXILIARY RELAY** → **OK**

Options

(an * will be displayed to the right of the selected option.)

1. **PRE-WARN SIGNAL** – Activates a strobe or alarm before the gate moves. A delay can be set.
2. **MOVING SIGNAL** – Activates whenever the gate is in motion (no delay).
3. **OPENED SIGNAL** – Activates when the gate is fully open (indicator for gate position).
4. **CLOSED SIGNAL** – Activates when the gate is fully closed (indicator for gate position).

Delay Settings

The **ALL-BLDC PRO** also provides a delay option for open or close cycles, commonly used in swing gate applications.

Navigation

From the LCD menu:

English → **SETTINGS** → **LEAF DELAY** → **OK**

Adjustment

1. **Direction** – while cursor at **DELAY CLOSE**, press **OK**, then use **UP** to toggle between **CLOSE** and **OPEN**. Press **OK** to confirm.
2. **Time** – Scroll to **DELAY**, press **OK**, then use **UP/DOWN** to set the delay (in seconds). Press **OK** to save.
3. **Secondary Operator** – If used, repeat the process on the secondary operator, but set the delay in the **opposite direction**.

⚠ **Important:** Only one direction (OPEN or CLOSE) can have a delay.

SL-175DC PRO ENTRAPMENT PROTECTION INSTALLATION

Minimum Devices

- A minimum of **two (2) monitored entrapment protection devices** are **required** for each entrapment zone.

Definition

- An **entrapment zone** is any location where a person can become trapped between a **moving gate** and a **rigid object**.

Built-In Protection

- The operator includes an **inherent entrapment protection system (ERD)**.

External Protection

- The gate operator also **requires external monitored entrapment protection devices** for each entrapment zone before operation.

- Approved devices include:

- **Non-contact photoelectric sensors**
- **Contact edges**

Monitoring Function

- The operator cycles power to the external entrapment devices and verifies proper signals.
- If correct feedback is **not received**, the gate will **not operate**.

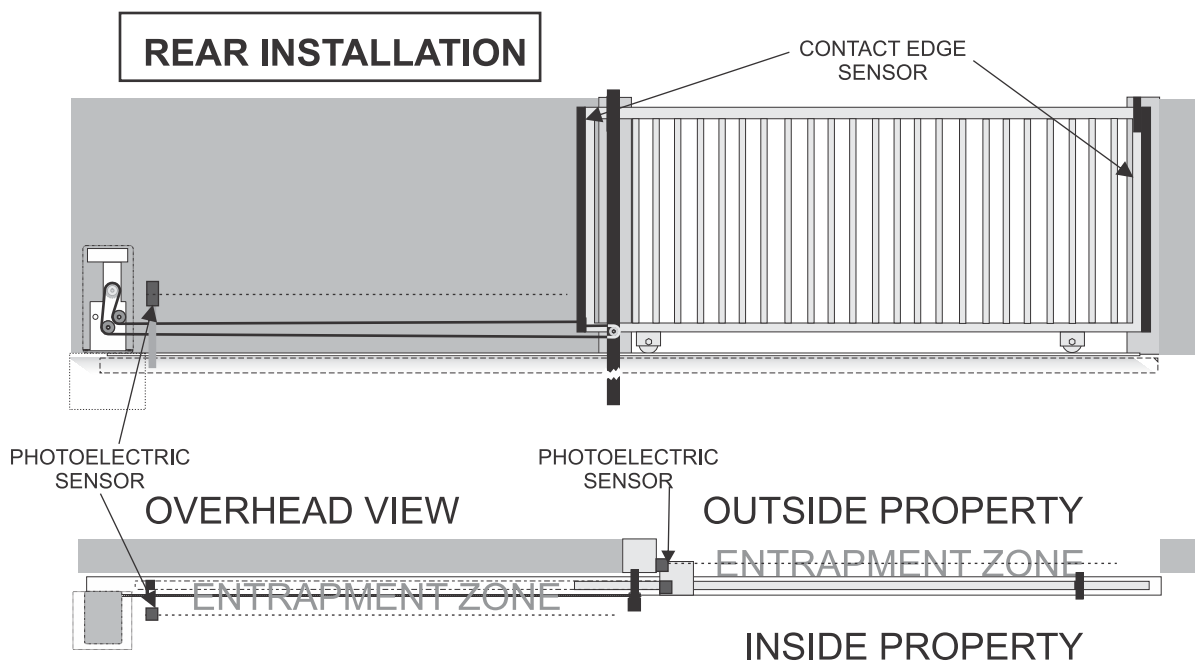
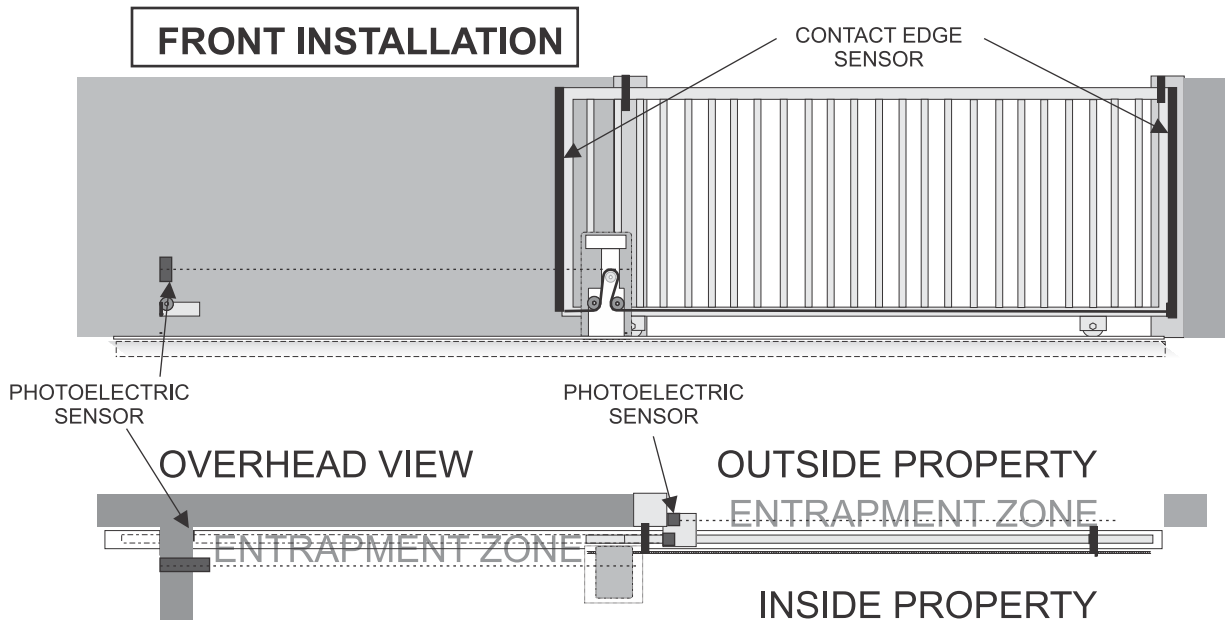

SW-375DC PRO ENTRAPMENT PROTECTION INSTALLATION

Minimum Devices

- A minimum of **two (2) monitored entrapment protection devices** are **required** for each entrapment zone.

Definition

- An **entrapment zone** is any location where a person can become trapped between a **moving gate** and a **rigid object**.

Built-In Protection

- The operator includes an **inherent entrapment protection system (ERD)**.

External Protection

- The gate operator also **requires external monitored entrapment protection devices** for each entrapment zone before operation.

- Approved devices include:

- **Non-contact photoelectric sensors**
- **Contact edges**

Monitoring Function

- The operator cycles power to the external entrapment devices and verifies proper signals.
- If correct feedback is **not received**, the gate will **not operate**.

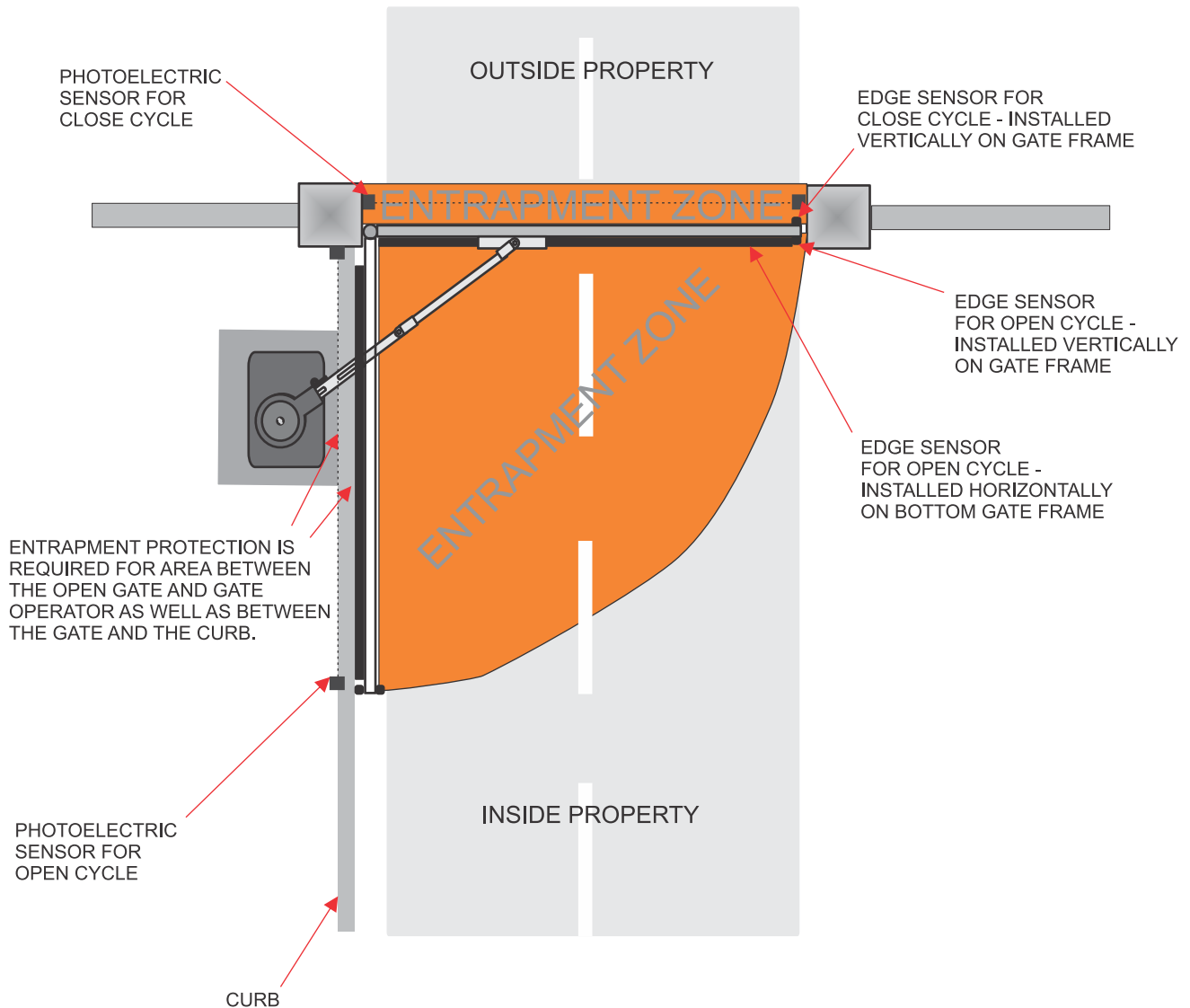

Monitored Entrapment Protection: Wiring Instructions

OVERHEAD VIEW OF DRIVEWAY

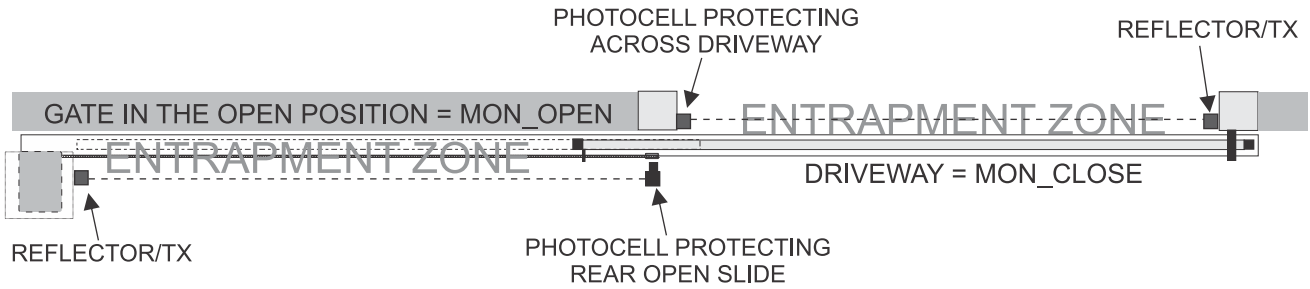

Wiring Entrapment Device to Control Board

MON-CLOSE: Wiring a Device Across the Driveway (Close Direction)

Wiring the **AOM-RED-EYE** to the Control board (Included with Operator)

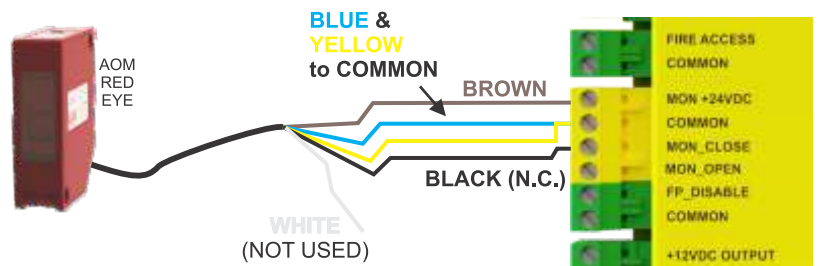

MON-OPEN: Wiring a Device Across the Driveway (Open Direction)

Wiring the **AOM-RED-EYE** to the Control board (Included with Operator)

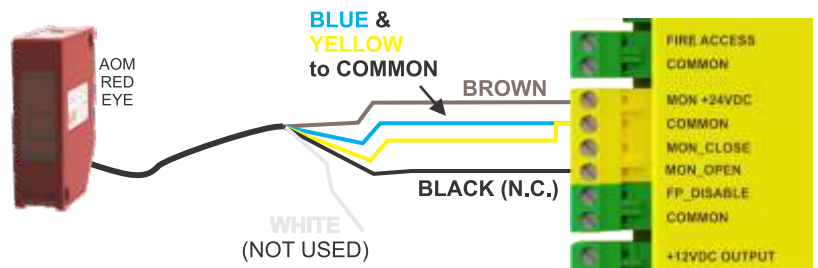

10K Termination Option

The ALL-BLDC PRO supports a 10K termination alternate option.

- Connect the **10K sensor contacts** to **COMMON** and **MON-OPEN** or **MON-CLOSE**, as shown below.

Close contact edge with 10K termination

Open contact edge with 10K termination

Auxiliary Inputs for Entrapment Protection

- AUX INPUT 1** and **AUX INPUT 2** can be used to connect additional entrapment protection devices (10K or N.C. termination).
- For **N.C. devices**, power must be connected to **MON +24VDC**.
- For **10K devices**, power may be connected to **+12VDC** or **+24VDC** if the device requires power.
- Refer to the **LCD Display section** for input programming details.

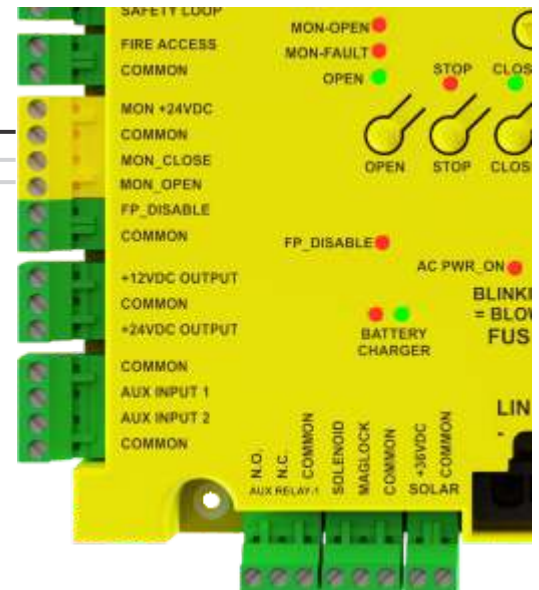

3RD PARTY MONITORED ENTRAPMENT PROTECTION DEVICE CONNECTIONS

• Monitored Entrapment Protection Devices

Sensor Types

To comply with **UL 325 monitored entrapment requirements**, the operator supports two sensor types:

- **Non-contact sensors** (photo eyes)
- **Contact sensors** (edge sensors)

Wiring Instructions

Monitored entrapment protection devices require **4 wires**:

1. From the device, connect **Relay Common** → **Board COMMON**.
2. Connect **Normally Closed (N.C.) relay contact** → **MON-OPEN or MON-CLOSE input**.
3. Use **MON +24VDC** and **COMMON** to power the device and enable monitoring.

Important Notes

- ⚠ **10K Termination** – The **ALL-BLDC PRO** also supports 10K termination devices. (See previous page for wiring details.)

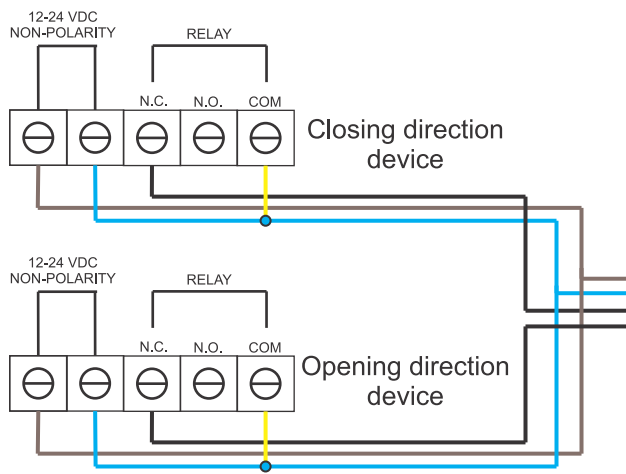

- **Power Behavior** – The **MON +24VDC** terminal is **off** when the gate is at rest.

- It is normal to see the **MON-OPEN** and **MON-CLOSE** LEDs **ON** when the gate is closed.
- The same applies if the auto-close timer is **OFF** and the gate is resting in the open position.
- If no devices are connected, both LEDs will remain ON.

- **Manufacturer Guidance** – Always follow the **device manufacturer's wiring instructions**, using **N.C.** wiring directions unless otherwise specified.

- **Expansion** – If more than one entrapment protection device is required for each direction, use **AUX INPUT 1** or **AUX INPUT 2** as monitored input expansion. (See **LCD Display AUX input** section for programming the inputs as **MON-OPEN** or **MON-CLOSE**)

MON-CLOSE

(LED indicates obstruction or missing device)

- Used for the **monitored entrapment device in the close direction**.
- When closing, the gate will:
 - **Reopen fully** if an obstruction is detected.
 - **Reset the auto-close timer**.
- Has no effect during opening.
- If no device is connected or a fault is detected (**MON_FAULT LED ON**), the operator will only run with a **constant pressure switch**.
- Once the obstruction is cleared, normal operation resumes.

MON-OPEN

(LED indicates obstruction or missing device)

- Used for the **monitored entrapment device in the open direction**.
- When opening, the gate will:
 - **Reverse for 2 seconds and stop** if an obstruction is detected.
- Has no effect during closing.
- If a device is connected but a fault is detected (**MON_FAULT LED ON**), the operator will only run with a **constant pressure switch**.
- Once the obstruction is cleared, normal operation resumes.

ALTERNATE UL APPROVED MONITORED ENTRAPMENT PROTECTION DEVICE WIRING

Edge Sensors:

Miller Edge Inc (FDDR2/8.E147902):
Models RB-G-K10, MGO20

EMX Industries Inc (FDDR2/8.E315703):
Models WEL-200

BBC Bircher (FDDR2/8/E526858):
Model XL-CP series – For use only with the Bircher XRF wireless transmission system only.

Transmission System:

BBC Bircher (FDDR2/8/E526858):
Model XRF-R.2, XRF-TI.

Refer to the device manufacturer’s wiring instructions when installing.

MON-CLOSE – Protects across the driveway during **closing**.

MON-OPEN – Protects the rear slide during **opening**.

Photoeyes:

EMX Industries Inc (FDDR2/8.E315703):
Models IRB-RET2, IRB-MON2

Miller Edge Inc (FDDR2/8.E147902):
Models TG-R, OG-T

Expansion Module:

Miller Edge Inc (FDDR2/8.E147902):
Models MIM62Wireless

OMRON E3K-R10K4-NR		
SWITCH	CONTACT	BOARD TERMINAL
LIGHT ON	N.O.2	MON_CLOSE OR MON_OPEN
	C.2	COMMON
	24 TO 240 VAC	COMMON
	24 TO 240 VAC	MON_12/24VDC

EMX NIR-50-325	
WIRE	BOARD TERMINAL
BLACK	MON_CLOSE OR MON_OPEN
WHITE	COMMON
BLUE	COMMON
BROWN	MON_12/24VDC

EMX IRB-MON		
SWITCH	CONTACT	BOARD TERMINAL
SW1 - OFF	N.C.	MON_CLOSE OR MON_OPEN
SW2 - OFF	COM	COMMON
SW3 - ON	POWER/VRX	COMMON
SW4 - OFF	POWER/VRX	MON_12/24VDC

EMX IRB-325	
CONTACT	BOARD TERMINAL
N.C.	MON_CLOSE OR MON_OPEN
COM	COMMON
POWER	COMMON
POWER	MON_12/24VDC

EMX IRB-RET/2		
SWITCH	CONTACT	BOARD TERMINAL
SW1 - OFF	N.C.	MON_CLOSE OR MON_OPEN
SW2 - OFF	COM	COMMON
SW3 - OFF	POWER/VRX	COMMON
SW4 - ON	POWER/VRX	MON_12/24VDC

EMX WEL-200	
CONTACT	BOARD TERMINAL
RELAY CLOSE (NC) RELAY OPEN (NC)	MON_CLOSE MON_OPEN
RELAY CLOSE (COM) RELAY OPEN (COM)	COMMON COMMON
POWER	COMMON
POWER	MON_12/24VDC

MILLER EDGE RBAND 6 WIRES FOR 1 EDGE - 8 WIRES FOR 2 EDGES		
SWITCH	CONTACT	BOARD TERMINAL
SW 1 - ON	N/C N/C	MON_CLOSE MON_OPEN
SW 2 - ON	COM COM	COMMON COMMON
SW 3 - ON	COM A.TEST	COMMON MON_12/24VDC
SW 4 - ON	12/24 (+) AC/DC	24-VDC GROUND

SL-175DC PRO LOOP LAYOUT

- Below is a typical loop layout. When connecting to an All-O-Matic circuit board, use the following:
 - Safety Loop - Normally Closed (N.C) Contacts
 - Exit Loop - Normally Open (N.O.) Contacts
- Wires **MUST** be twisted from the exit point of the loop saw cut to the gate operator.
- Twist loop wires 6 turns per foot, as shown below. Improper twisting of wires can cause loop issues.
- When using an inside and outside safety loop, loops must be **WIRED IN SERIES**.

OUTSIDE PROPERTY

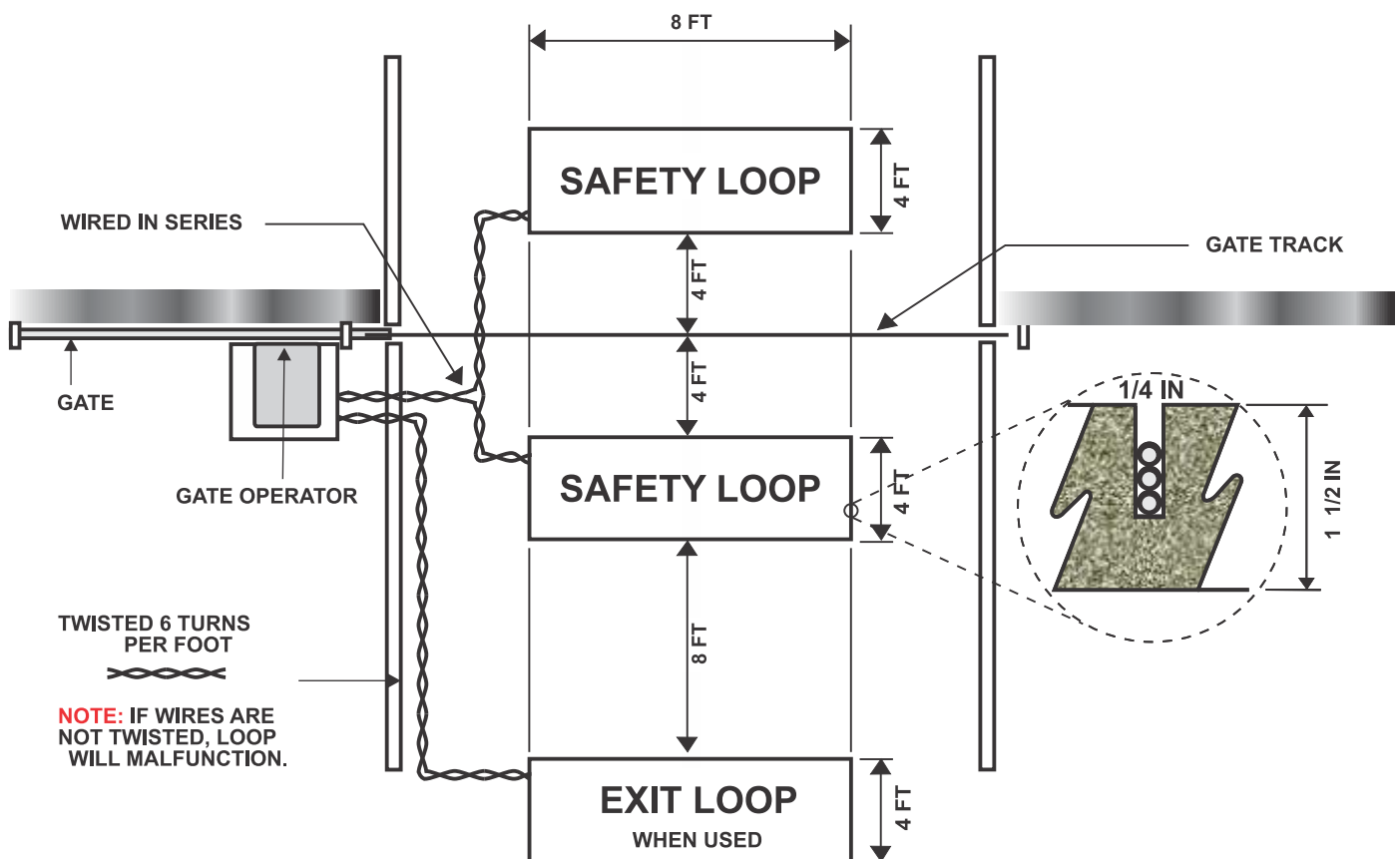

INSIDE PROPERTY

SW-375 DC LOOP LAYOUT

- Below is a typical loop layout. When connecting to an All-O-Matic circuit board, use the following:
 - Safety Loop - Normally Closed (N.C) Contacts
 - Exit Loop - Normally Open (N.O.) Contacts
- Wires **MUST** be twisted from the exit point of the loop saw cut to the gate operator.
- Twist loop wires 6 turns per foot, as shown below. Improper twisting of wires can cause loop issues.
- When using an inside and outside safety loop, loops must be **WIRED IN SERIES**.

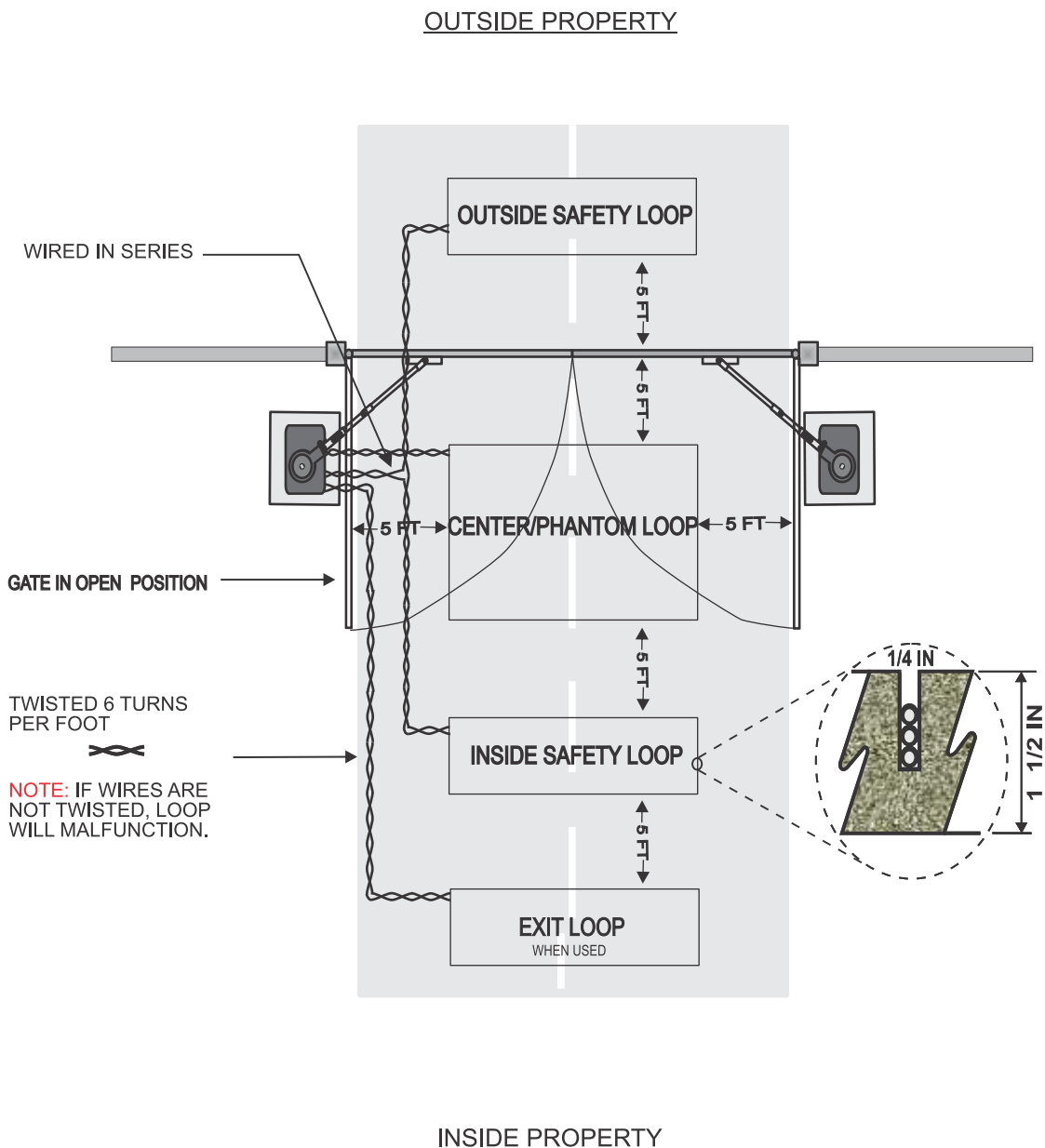

PLUG-IN DETECTOR INSTALLATION

- The SL-175DC PRO, SW-375DC PRO models come equipped with the pre-wired LPR-2 loop rack for safety phantom and exit plug in loop detectors, making installation quick and efficient.
- Hardwired loop detectors with harnesses can also be installed. The circuit board has 12 VDC and 24 VDC terminals to power the detector of your choice. See “Accessory Connections” page for wiring instructions.
- Wire one or more safety devices in series with the loop rack wires. To do this, remove the white wire (N.C) from the loop rack off of the SAFETY terminal on the circuit board and wire nut to the COM of the additional device. The N.C. contact of the additional device will now go on the SAFETY terminal of the board.
- **IMPORTANT:** Use different frequencies for each loop detector to eliminate interference.

LOOP RACK	DC BOARD	WIRE COLOR
+V	+12VDC	RED
-V	COMMON	BLACK
EXIT LOOP	EXIT LOOP	GREEN
PHAN	PHAN LOOP	BROWN
SAFETY	SAFETY LOOP	WHITE

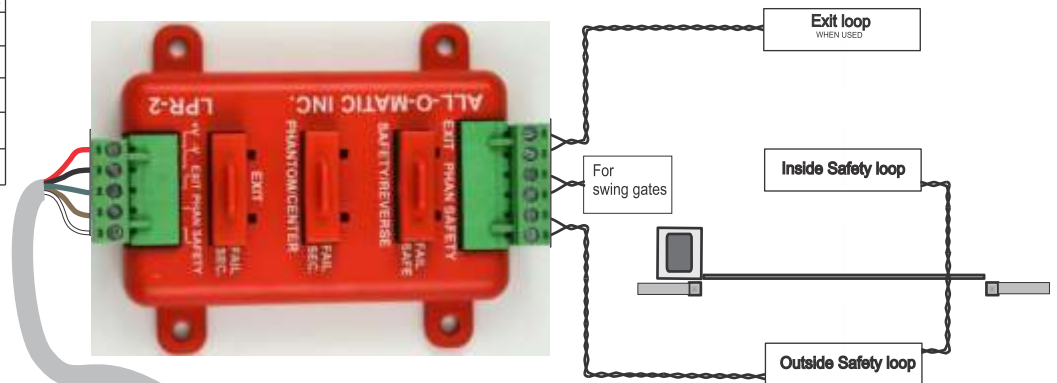

Remove Safety loop wire jumper when a SAFETY LOOP detector is installed.

STOP	P/S LINK
CLOSE	RADIO
+12VDC	EXIT LOOP
COMMON	PHAN LOOP
EXIT LOOP	SAFETY LOOP
PHAN LOOP	FIRE ACCESS
SAFETY LOOP	MON-CLOSE
FIRE ACCESS	MON-OPEN
COMMON	MON-FAULT
	OPEN



PRIME-VD1 VEHICLE DETECTOR

INDICATORS:
RED - DETECT
GREEN - PWR/LOOP FAIL

SETTINGS

SENSITIVITY	SW1	SW2
LOW	OFF	OFF
MEDIUM LOW	ON	OFF
MEDIUM HI	OFF	ON
HIGH	ON	ON

FREQUENCY	SW5	SW6
HIGH	OFF	OFF
MEDIUM HI	ON	OFF
MEDIUM LOW	OFF	ON
LOW	ON	ON

GREEN LED BLINKING
INDICATE LOOP FAIL:
1 BLINK - OPEN LOOP
2 BLINKS - LOOP SHORTED

OUTPUT	SW3
FAIL-SECURE	OFF
FAIL-SAFE	ON

USE FAIL-SAFE FOR SAFETY/
REVERSE LOOP, FAIL-SECURE
FOR EXIT OR PHANTOM LOOPS.

PRESS RESET AFTER CHANGING SENSITIVITY
AND FREQUENCY SETTINGS

IMPORTANT: Dip switch **SW3** on PRIME-VD1 must be set when installing the detector in order for it to work properly.

Use chart to set the output of the detector either **FAIL-SECURE** (N.O.) or **FAIL-SAFE** (N.C.).

OFF will set the output as **FAIL-SECURE** and **ON** will set output as **FAIL-SAFE**. See chart below.

OUTPUT	SW3
EXIT/PHANTOM	OFF
SAFETY	ON

ACCESSORY WIRING

Auxiliary Power & Inputs

- **Accessory Power** – +12VDC (750 mA) and +24VDC (750 mA) available. Use a **separate power supply** if accessory draw exceeds these limits.
- **Factory Jumpers** – Remove jumpers when wiring:
 - Safety loop: **COMMON** ↔ **SAFETY LOOP**
 - Stop button: **STOP** ↔ **COMMON**
- **Aux Inputs (1 & 2)** – Programmable as **N.O.**, **N.C.**, or **10K** for entrapment devices. See **LCD Display** section for setup.

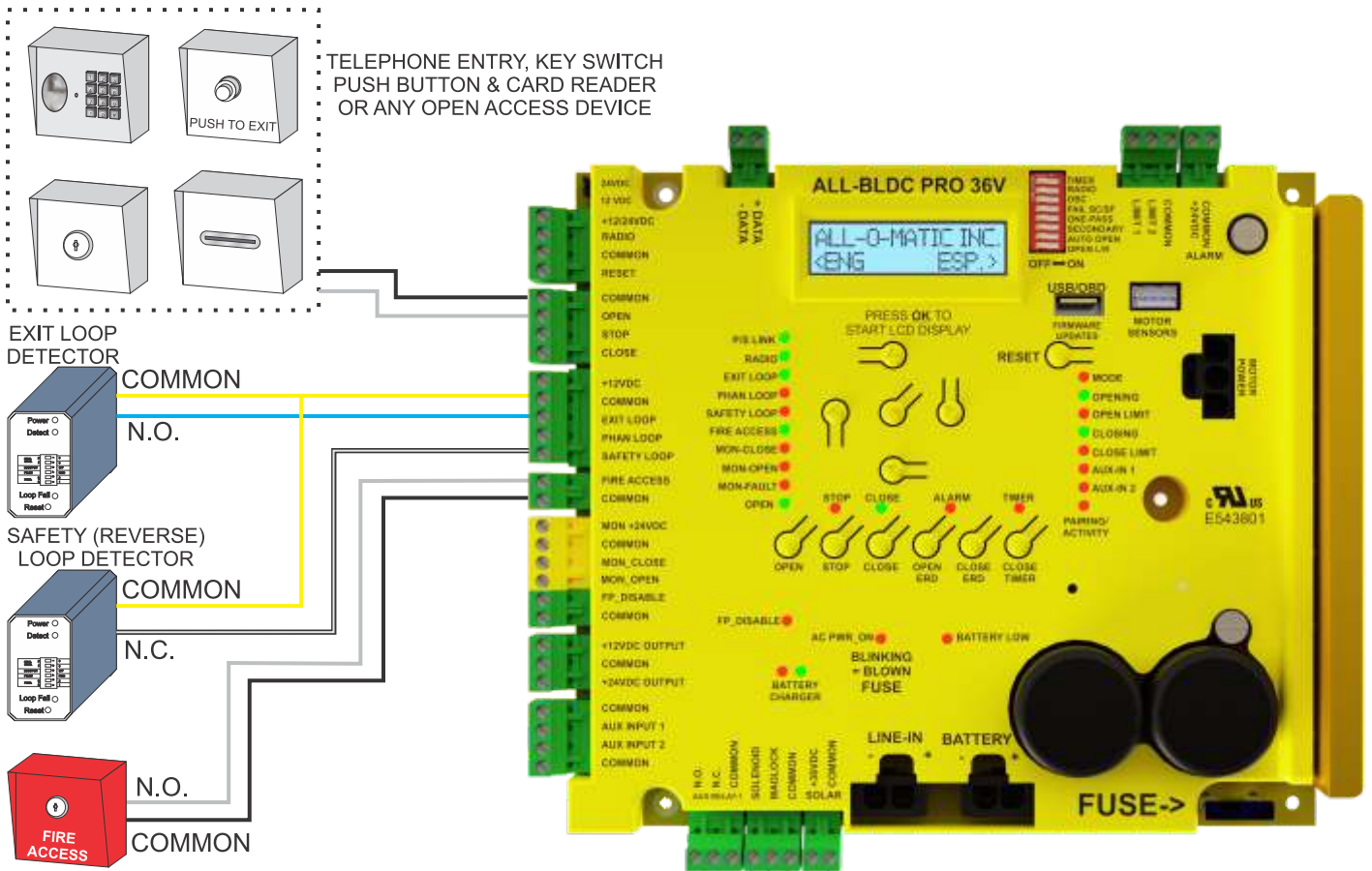

Lock Release Delay

- The **ALL-BLDC PRO** includes a **0.5s built-in delay**.
- Some locks may require a **longer delay** to release.
- Adjust delay under **Auxiliary Relay & Leaf Delay settings**.
- ⚠ Delay can be set on either **Primary** or **Secondary** operator.

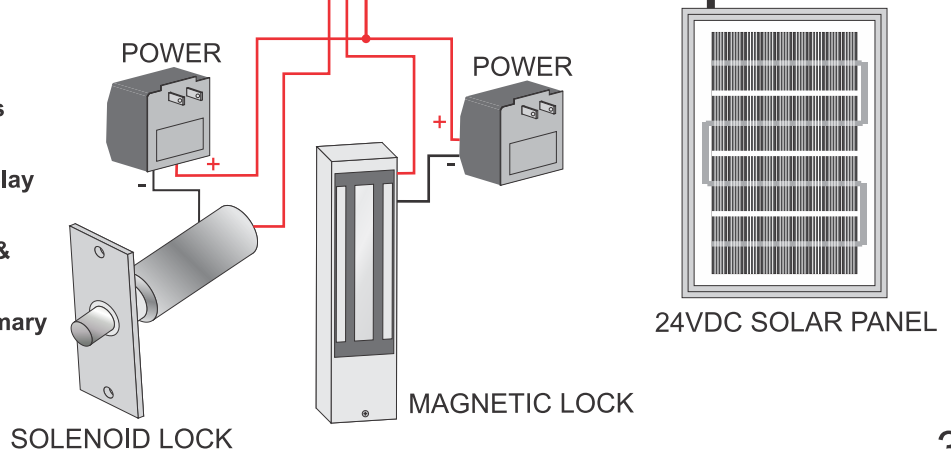

ACCESSORY WIRING (CONT.)

Three-Button Station

- The control board includes an **integrated 3-button station** and **RESET button** for limit and ERD adjustments.
- An **external 3-button station** may also be installed. (See wiring diagram below.)
- **Important:** Remove the **STOP jumper** when installing an external 3-button station.

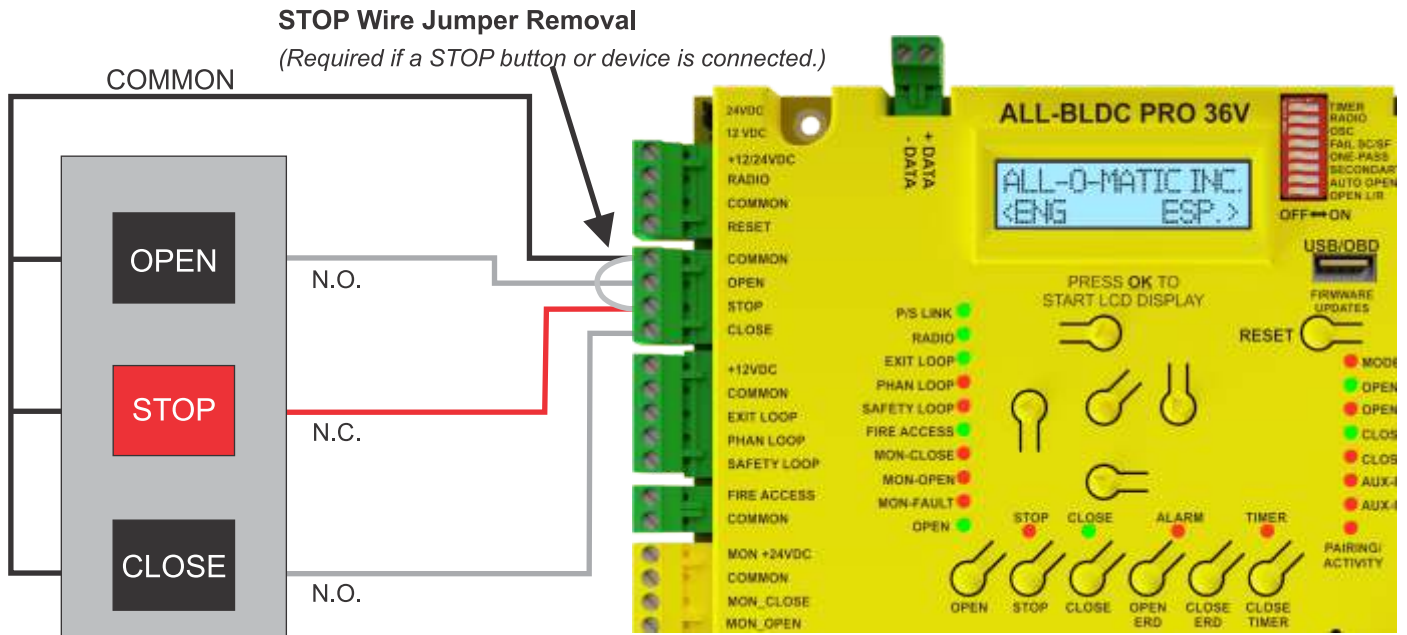

Magnetic & Solenoid Lock Installation

- **Power Requirement** – A **step-down transformer** with the correct voltage is required for the lock accessory.
 - Most operators include a **120VAC outlet** for the transformer.

Connections

1. Plug the **transformer** into the 120VAC outlet receptacle.
2. From the transformer's low-voltage side:
 - Connect one wire directly to the **lock device**.
 - Connect the second wire to the board's **Lock Relay COMMON terminal**.

Lock Wiring

- **Magnetic Lock** → Connect the second lock wire to the **MAGLOCK terminal** on the relay.
- **Solenoid Lock** → Connect the second lock wire to the **SOLENOID terminal** on the relay.

(See wiring diagram for reference.)

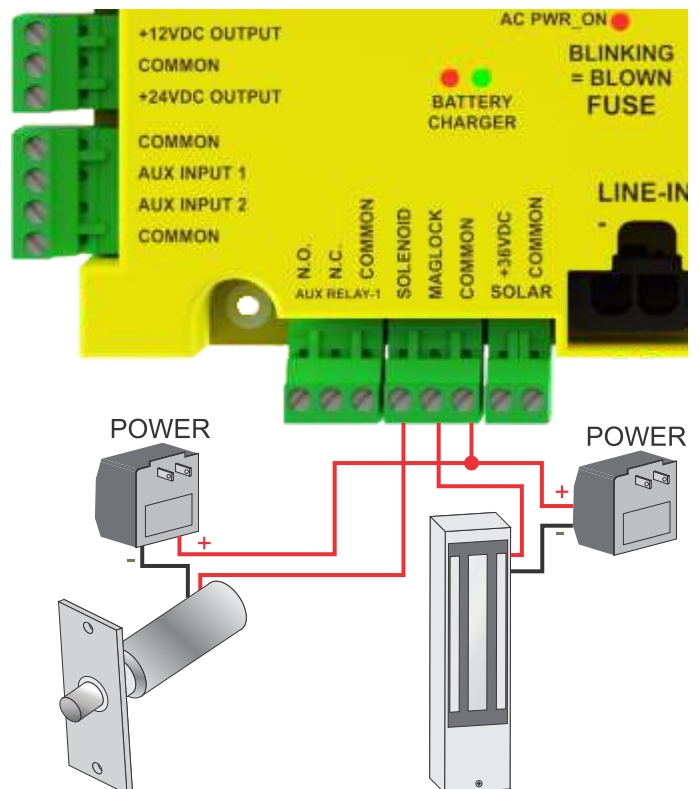

SOLAR PANEL CONNECTION

Solar Panel Requirements

- **Panel Size** – Minimum **48VDC, 40W** panel required.
- **Capacity** – Charging circuit supports up to **80W**.
- With **(3) 14Ah 12VDC batteries**, a receiver, and **(2) monitored entrapment devices**, operators can provide about **20 cycles/day**.

Installation Notes

- Always use the **SOLAR input** for solar panels.
- The onboard regulator includes **MPPT technology** for higher efficiency.
- For heavier use, upgrade to **larger batteries**.
- If more than **80W solar power** is required, use an **external charge controller/regulator**. (See next page for details.)

Additional Information

For solar applications (panel sizing, battery capacity, etc.), contact **All-O-Matic**.



MPPT ON BOARD
REGULATOR
90+% EFFICIENCY

CONNECT BATTERY
HARNESS TO BATTERY
PLUG ON THE BOARD

CONNECT 48V PANEL
INTO **SOLAR**
INPUT
ON CIRCUIT BOARD.

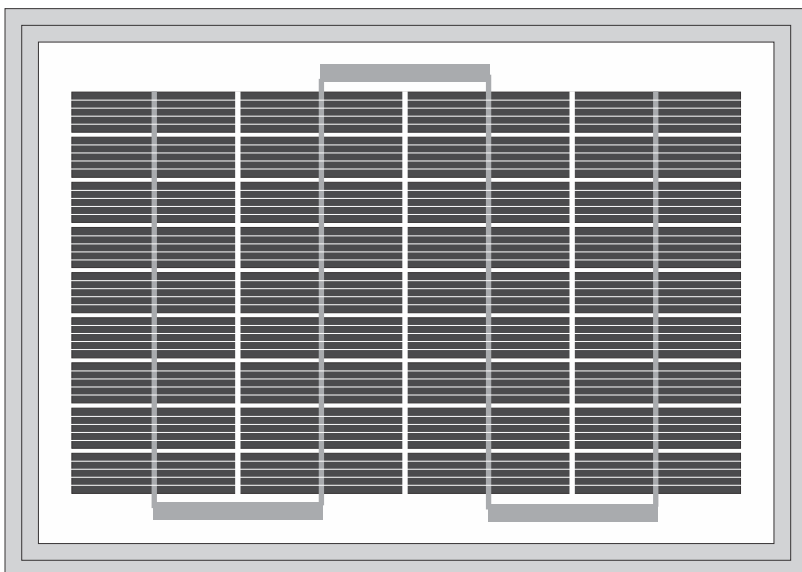

EXTERNAL SOLAR SYSTEM INSTALLATION

External Solar Package

- Connect **batteries directly to the BATTERY input**.
- Batteries must be **upgraded to match application requirements**. (See *wiring diagram below*.)

Important Wiring Notes

- If more than **two solar panels** are used, special wiring precautions are required to avoid battery or regulator damage:

- **24VDC panels** → wire in **series** to make 48VDC.
- **48VDC panels** → wire in **parallel**.

Additional Information

For details on solar panel sizing, battery capacity, and application planning, contact **All-O-Matic**.

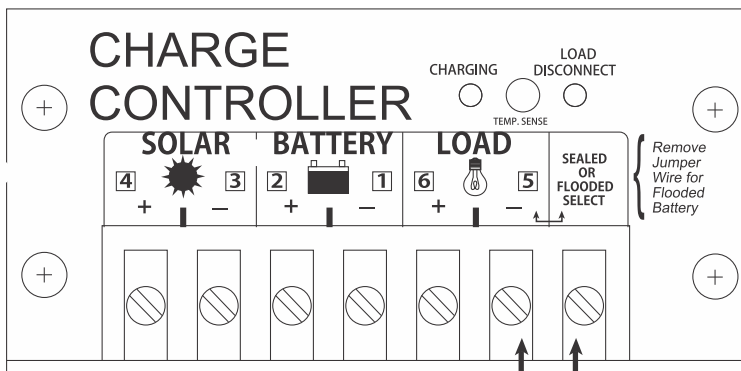

CONNECT BATTERY PLUG INTO BATTERY ON CIRCUIT BOARD

3 Batteries wired in series to make 36VDC

LED Indicator Reference

Communication & Control

- **P/S LINK** – ON when Primary/Secondary communication is active.
- **RADIO** – ON when the RADIO input is activated (closed to COMMON).
- **EXIT LOOP** – ON when the EXIT input is activated (closed to COMMON).
- **PHANTOM LOOP** – ON when the PHANTOM LOOP input is activated (closed to COMMON).
- **SAFETY LOOP** – ON when the SAFETY LOOP input is activated (open to COMMON).
- **FIRE ACCESS** – ON when the FIRE ACCESS input is activated (closed to COMMON).

Monitored Inputs

- **MON-CLOSE** – ON when the MON-CLOSE input is activated (open to COMMON) or if no device is installed.
- **MON-OPEN** – ON when the MON-OPEN input is activated (open to COMMON) or if no device is installed.
- **MON-FAULT** – ON if a fault is detected on MON-OPEN or MON-CLOSE devices (device missing or malfunctioning).

Manual Controls

- **OPEN** – ON when OPEN input or push button is activated (closed to COMMON). Can be ON with other inputs.
- **STOP** – ON when STOP input or push button is activated (open to COMMON).
- **CLOSE** – ON when CLOSE input or push button is activated (closed to COMMON).

Alarms & Timers

- **ALARM** – Turns ON for 5 minutes when operator shuts down after hitting an

obstruction (ERD) twice before closing.

- **TIMER** – Blinks every 0.5s while counting down for auto-close.
- **MODE** –
 - 1 blink / 2s = motor sensor feedback problem.
 - 2 blinks / 2s = motor overload.
 - 3 blinks / 2s = gate jammed.

Gate Position

- **OPENING** – ON while gate is opening.
- **OPEN-LIMIT** – ON when the open limit switch is activated.
- **CLOSING** – ON while gate is closing.
- **CLOSE-LIMIT** – ON when the close limit switch is activated.

Auxiliary & Other Inputs

- **AUX-IN 1** – ON when AUX INPUT 1 is activated (closed to COMMON).
- **AUX-IN 2** – ON when AUX INPUT 2 is activated (closed to COMMON).
- **FP-DISABLE** – ON when the foot pedal is pressed.

Power Status

- **AC/PWR ON** – ON when AC power is present. Blinks every 0.5s if the main board fuse is blown.
- **LOW-BATTERY** – ON when batteries are low, off, or disconnected.

Tips

- When troubleshooting, **always note which LEDs are ON** — they indicate board activity and active inputs.
- When calling **All-O-Matic Technical Support**, have the list of active LEDs ready. This will **speed up diagnosis** and help restore operation quickly.

TECHNICAL TIPS

Operator Symptom	Solutions (diganose)
Opening or closing LEDs are on, but gate doesn't move	If AC PWR_LED is blinking, replace the fuse at bottom right corner of the board. After replacing the fuse and before a signal is given, inspect the gate and make sure it's not bound up and that the limit switches are set correctly. If gate still doesn't run, check motor harness and make sure it is plugged in correctly and no wires are loose.
Radio receiver doesn't work	Jumper at top left corner by factory is set on 12VDC. If the receiver requires 24VDC, move the jumper to 24VDC.
AC PWR_ON LED is off	Make sure main high voltage power is connected and AC power switch is in the ON position. If that is fine, check 10Amp fuse in EMI board in the power box. If it's blown, check rectifier, it may also be damaged and need to be replaced along with the 10Amp fuse.
Gate opens very slow	Check limit switch adjustment. Usually when gate opens very slow it is due to gate hitting the receiving post or positive stop before close limit swith activates. Check the variable speed setting to be sure it's set at 100%. Check that the AC power is turned ON and that the AC PWR_ON LED is lit. Also, make sure limit learning has been done. See below.
Learning the limits for soft stop function.	Set the gate in closed position with the close limit activated. Press and release the RESET button on board. Run the gate a full cycle (full open and full close) without interruption. The first cycclle will be slower while learning the distance between limits. It will run full speed once limits have been learned.
Gate does not run and ALARM LED is ON	Gate is in Shut down mode due to obstruction detection. Press red RESET button outside control box next to radio connector. Run the gate and inspect gate is not bound up or jammed. Test ERD sensivity. See ERD adjusment page for details on the adjustment.
Gate does not run and FP_DISABLE is ON	Check foot pedel and make sure it's up. Foot pedal has a kill switch and when it's down, it disables the operator.
Gate does not run and STOP LED is ON	Check STOP input device and make sure it is not activated. Remember, this input is N.C. and LED will stay on if the wrong contact is used.
Gate does not run and MODE LED blinks	See LED DIAGNOSTICS for details on the meaning of the blinks.
Gate doesn't close	Check LEDs, any of the following input LEDs will prevent gate from closing. Check inputs for LEDs that are ON: RADIO, OPEN, STOP, EXIT LOOP, PHAN LOOP, SAFETY LOOP, FIRE ACCES, MON-CLOSE (check wiring and alignment), FP_DISABLE, (AUX INPUT 1 & 2, depending on programmed function). Also, check if AC PWR_ON LED is OFF(if it's OFF and dip-switch 4 or 7 are ON, gate will remain open).
Gate doesn't open	Check LEDs, any of the following input LEDs will prevent gate from opening. Check inputs for LEDs that are ON: STOP, CLOSE, MON-OPEN, FP-DISABLE and AUX INPUT 1 or 2 (depending on programmed fuction). Also, check if AC PWR_ON LED is OFF (if it's OFF and dip-switch 4 is OFF, gate will remain closed if battery is low)
Gate stops and reverses before reaching limits	Check ERD. If no obvious obstruction is present, it may need to be adjusted and increase the force for the direction it is stopping. See ERD adjustment page for details.
Gate stops and reverses open	Check LEDs and see if any of them turn ON when gate reverses. It may be that the gate movement might be activating that device. See above the devices that prevents gate from closing.

AUX INPUT 1 & 2 PROGRAMMING

AUX INPUT 1 & 2 can be programmed to do different functions. Below are the options

1. AUX INPUT 1

- 1. EMERGENCY OPEN** (factory default)
Devices connected to the input in this function, will open the gate and will override MON-OPEN devices. Use N.O. contact.
- 2. PARTIAL OPEN** (set partial open in %)
Devices connected to this input in this function, will open the gate partially to set opening %. Use N.O. contact from device relay.
- 3. OPEN-CMD**
Devices connected to this input in this function, will open the gate. Use N.O. contact from device
- 4. CLOSE-CMD**
Devices connected to this input in this function, will close the gate. Use N.O. contact.
- 5. MON-OPEN**
In this function, this input is an expansion for open direction entrapment protection devices. N.C. or 10K termination can be used on device.
IMPORTANT: If N.C. termination is used, must use MON +24VDC to power device.
- 6. MON-CLOSE**
In this function, this input is an expansion for close direction entrapment protection devices. N.C. or 10K termination can be used on device.
IMPORTANT: If N.C. termination is used, must use MON +24VDC to power device.
- 7. STOP-CMD**
Devices connected to this input in this function, will stop the gate. Use N.C. contact.

2. AUX INPUT 2

- 1. EMERGENCY CLOSE** (factory default)
Devices connected to the input in this function, will close the gate and will override MON-CLOSE devices. Use N.O. contact.
- 2. PARTIAL OPEN** (set partial open in %)
Devices connected to this input in this function, will open the gate partially to set opening %. Use N.O. contact from device relay.
- 3. OPEN-CMD**
Devices connected to this input in this function, will open the gate. Use N.O. contact from device
- 4. CLOSE-CMD**
Devices connected to this input in this function, will close the gate. Use N.O. contact.
- 5. MON-OPEN**
In this function, this input is an expansion for open direction entrapment protection devices. N.C. or 10K termination can be used on device.
IMPORTANT: If N.C. termination is used, must use MON +24VDC to power device.
- 6. MON-CLOSE**
In this function, this input is an expansion for close direction entrapment protection devices. N.C. or 10K termination can be used on device.
IMPORTANT: If N.C. termination is used, must use MON +24VDC to power device..
- 7. STOP-CMD**
Devices connected to this input in this function, will stop the gate. Use N.O. contact.

See next page on details on how to navigate through LCD display menu to program desired function on AUX INPUT 1 & 2.

Connect device relay contacts to these two terminals. Relay COMMON to board COMMON. RELAY N.O., N.C. or 10K to AUX INPUT 1. The relay contact depends on the function. See above for contact options.

Connect device relay contacts to these two terminals. Relay COMMON to board COMMON. RELAY N.O., N.C. or 10K to AUX INPUT 2. The relay contact depends on the function. See above for contact options.

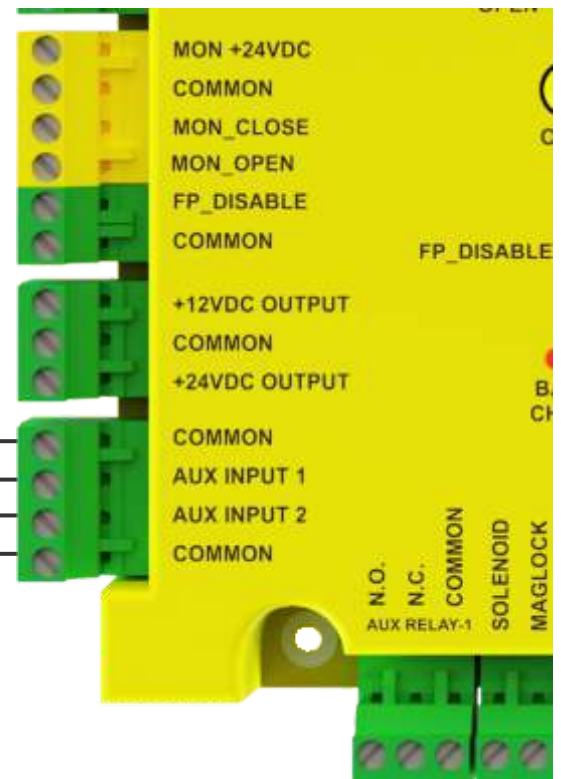

LCD SETTINGS AND DIAGNOSTICS

These instructions will take you through the ALL-BLDC PRO board LCD display menu.

Press OK a few times to wake the display until the options <ENG> and <ESP> appear. Select English with the left button or Spanish with the right button. After choosing a language, scroll to Settings or Diagnostics and press OK to enter. Use the up and down buttons to scroll, left and right to move the cursor, and press OK to save or select items.

SETTINGS

1. TIME/DATE

- **1.1 TIME (XX:XX AM/PM)**
 1. Press **OK** when the cursor is on **TIME**.
 2. Use **Left/Right** to move between hour, minutes, and AM/PM.
 3. Use **Up/Down** to adjust values.
 4. Press **OK** to save.
- **1.2 DATE (MM/DD/YYYY)**
 1. Press **OK** when the cursor is on **DATE**.
 2. Use **Left/Right** to move between month, day, and year.
 3. Use **Up/Down** to adjust values.
 4. Press **OK** to save.

2. SPEED

- **2.1 MAX SPEED (100%)**
Adjusts the motor's maximum running speed.
- **2.2 ACCELERATION (FST)**
Adjusts how quickly the motor ramps up to speed.
- **2.3 SLOW DOWN (2 FEET)**
Adjusts the distance for when the motor begins slowing down as it approaches the limit switch.

3. POWER

- **3.1 CURR. SENSE (PRGV)**
Adjusts how responsive the ERD is. Options are **Progressive** and **Threshold**, with **Threshold** being the most sensitive.
- **3.2 ERD**
 - o **OPEN ERD** – Adjusts opening ERD force (also accessible with the quick-access **OPEN ERD** button).
 - o **CLOSE ERD** – Adjusts closing ERD force (also accessible with the quick-access **CLOSE ERD** button).

4. 7-DAY TIMER

- **4.1 EVENTS (1–10)**
Each event allows you to program an **Action** with an **Activate Time**, a **Deactivate Time**, and specific **Days of the Week**. Up to 10 events can be programmed.

Technician's Note: Run a full gate cycle before programming events to ensure proper operation.

- **4.2 EVENT ACTION OPTIONS**
(an * will be displayed to the right of selected action.)
 - o **OPEN** – Opens gate and holds it open.
 - o **CLOSE** – Closes gate and holds it close.

- o **AUXILIARY RELAY** – Activates the auxiliary relay.

4.3 PROGRAMMING AN EVENT (Step-by-Step)

i. Select an Event (1–10):

Scroll to the desired event number and press **OK**.

ii. Choose Action: Use **Up/Down** to select **OPEN**, **CLOSE**, or **AUXILIARY RELAY**, then press **OK**.

iii. Set Activate Time:

1. Cursor appears on the hour field.
2. Use **Left/Right** to move between hours, minutes, and AM/PM.
3. Use **Up/Down** to adjust values.
4. Press **OK** to confirm.

iv. Set Deactivate Time:

1. Follow the same process as above for the deactivate time.
2. Press **OK** to confirm.

v. Enable Days:

1. Scroll through days of the week (Mon → Sun).
2. Toggle each day **ON** or **OFF** using **Up/Down**.
3. After setting all days to the desired state, press **OK** to confirm.

vi. Save Event:

Once all steps are completed, the event is saved and ready to run.

5. LEAF DELAY

5.1 DELAY TYPE

Select whether the delay applies to **OPEN** or **CLOSE**. This function is mainly used for swing gates that overlap.

5.2 DELAY TIME (00.0 SEC)

Set the delay duration in seconds. Use **Up/Down** to adjust the value and press **OK** to confirm.

6. PRE-WARN ALARM

(Uses the built-in audible alarm to warn before the gate starts moving.)

6.1 ALARM ON/OFF

Enable or disable the alarm. Set to **ON** to activate, or **OFF** to deactivate.

6.2 DELAY TIME (00.0 SEC)

Adjust the number of seconds the alarm sounds before gate movement. Range: **0–12 seconds**. Use **Up/Down** to adjust the value, then press **OK** to confirm.

LCD SETTINGS AND DIAGNOSTICS (CONT.)

7. AUXILIARY RELAY

(Options for relay activation.)

7.1 RELAY MODES

Select one of the following functions for the auxiliary relay: (an * will be displayed to the right of selected mode.)

1. **OFF (INACTIVE)*** – Default setting; relay is disabled.
2. **PRE-WARN SIGNAL** – Activates before gate movement; functions similar to the Pre-Warn Alarm.
3. **MOVING SIGNAL** – Activates while the gate is moving.
4. **OPENED SIGNAL** – Activates when the gate is fully open.
5. **CLOSED SIGNAL** – Activates when the gate is fully closed.
6. **PULSE ON OPEN** – Sends a 1-second pulse when the open limit is reached.

8. AUXILIARY INPUT

(Input 1 defaults to EMERGENCY OPEN, and Input 2 defaults to EMERGENCY CLOSE.) See auxiliary input page for more details.

8.1 INPUT MODES (1–2)

Each auxiliary input can be configured with one of the following functions: (an * will be displayed to the right of selected mode.)

1. **EMERGENCY OPEN / CLOSE*** – Overrides monitored inputs and forces the gate to fully open or close.
2. **PARTIAL OPEN** – Opens the gate partially, based on the programmed percentage setting.
3. **OPEN_CMD** – Functions the same as a standard open input.
4. **CLOSE_CMD** – Functions the same as a standard close input.
5. **MON-OPEN** – Expansion of the monitored open input.
6. **MON-CLOSE** – Expansion of the monitored close input.
7. **STOP_CMD** – Functions the same as the STOP input.

9. RADIO LATCH

(Used to temporarily hold the gate open using the radio receiver.)

9.1 ACTIVATION

1. In the **SETTINGS** list, scroll to **RADIO LATCH** and press **OK**.
2. Use **Up** to turn the function **ON**, then press **OK** to confirm.

9.2 FUNCTION

1. When **ON**, activating the radio receiver will open the gate.
2. Once the gate is fully open, press the remote button again to enable **Hold Open** mode.
3. To release **Hold Open**, press the remote button once more. The gate will then time out and close.

4. While active, the display will show: **RADIO LATCH MODE ACTIVE**. This indicates the gate is held open by this function. To allow closing, press the remote button once; the gate will time out and close.

10. MON-INPUT

(Used to set the 10K device as either Safety Edge or Photo Eye.)

10.1 SETTINGS

1. Scroll to **MON-INPUT** in the menu and press **OK** twice.
2. Select **10K EDGE** or **10K PHOTO EYE**, then press **OK** to confirm.

10.2 FUNCTION

- o **10K EDGE** – Assigns the input to a safety edge device.
- o **10K PHOTO EYE** – Assigns the input to a photo eye sensor, preventing false alarms or shutdowns when detecting obstructions.

11. SERVICE CYCLE

(Provides a planned service reminder based on run cycles.)

11.1 SETTINGS

1. Scroll to **SERVICE CYCLE** in the menu and press **OK**.
2. Program the number of cycles the gate should run before the next preventive maintenance service call.
3. Press **OK** to confirm.

11.2 FUNCTION

- o The control board begins counting down from the programmed number.
- o When the count reaches zero, the board will beep to alert the end user that it's time to schedule service.
- o The cycle count can be reset by a technician in the **Diagnostics** → **Cycle Count** menu.

11.3 COUNT (00000)

1. Use **Left/Right** to move the cursor between tens, hundreds, thousands, and ten-thousands positions.
2. Use **Up/Down** to adjust the value.
3. Press **OK** to confirm.

12. AUTO CLOSE TIMER

(See timer page for more details on this)

12.1 SETTINGS

1. Scroll to **AUTO CLOSE TIMER** in the menu and press **OK**, or press the quick-access **TIMER** button.
2. Use **Up/Down** to set the delay (0–120 seconds).
3. Press **OK** to confirm.

LCD SETTINGS AND DIAGNOSTICS (CONT.)

13. SETTINGS CHG LOG

(Keeps a record of the last three times settings were changed.)

13.1 ENTRIES

01-03. SETTINGS CHG – XX/XX/XX 00:00 AM

Shows the saved date and time of the changes

14. FIRMWARE UPDATE

(Allows firmware to be upgraded in the field.)

14.1 UPDATE PROCESS

1. Obtain the firmware **BIN** file from AOM (provided via email).
2. Copy the file to a thumb drive formatted to **FAT, FAT16, or FAT32**.
3. Plug the thumb drive into the board's **USB port**.
4. Follow on-screen instructions to complete the update.

15. WIRELESS SETUP

(For wireless PRIMARY/SECONDARY setup. Assign unique channels if other systems are nearby. 8 channels available.)

15.1 WIRELESS CHANNEL

1. Ensure both operators in a pair are set to the **same channel**.
2. If other systems are nearby, select a different channel to avoid conflict.

16. SET TO DEFAULT

(Restore individual settings, or all settings, to factory defaults.)

16.1 OPTIONS

1. **DEFAULT ALL** – Restores all settings.
2. **DEFAULT SPEED** – Restores speed settings.
3. **DEFAULT POWER** – Restores power settings.
4. **DEFAULT 7/D TMR** – Restores 7-Day Timer settings.
5. **DEFAULT LEAF DLY** – Restores leaf delay settings.
6. **DEFAULT PRE ALRM** – Restores pre-warn alarm settings.
7. **DEFAULT AUX RLY** – Restores auxiliary relay settings.
8. **DEFAULT AUX INS** – Restores auxiliary input settings.
9. **DEFAULT RADIO LA** – Restores radio latch settings.
10. **DEFAULT MON 10K** – Restores mon-input settings.
11. **DEFAULT SVC CYC** – Restores service cycle settings.
12. **DEFAULT AUTO CLS** – Restores auto close timer settings.
13. **DEFAULT WIRELESS** – Restores wireless setup settings.

DIAGNOSTICS

1. GATE STATUS

Displays whether the gate is **CLOSED**, **OPENED**, or **STOPPED**.

2. COMMUNICATION

(Displays the current communication mode.)

1. **Wireless**
2. **Wired**

3. 7/D TMR STATUS

Displays if the gate is being held open or if the relay is active by the 7-Day Timer.

4. METER

(Provides real-time voltage readings.)

1. **BATT VOLTAGE** – Displays battery voltage.
2. **LINE IN VOLTAGE** – Displays line input voltage.

5. MOTOR

(Displays motor speed and gate travel as a percentage.)

- **5.1 MOTOR SPEED**
Shows the current operating speed of the motor.
- **5.2 TRAVEL**
Displays the percentage of gate travel completed.

6. LAST EVENT

(Displays the most recent event recorded by the system.)

- **6.1 EVENT NAME**
Example: **50. (LAST LOGGED EVENT NAME)**
- **6.2 EVENT DATE & TIME**
Example: **XX/XX/XX 00:00 PM**

8. EVENT LOG

(Stores up to 50 special events.)

- **8.1 LOGGED EVENTS**
Displays entries **1–50** in the event log.

9. CYCLE COUNT

(Displays the unit's cycle counts, including service cycles if programmed.)

- **9.1 LIFE CYCLES**
Total number of cycles since installation.
- **9.2 MONTH CYCLES**
Total cycles for the current month.
- **9.3 DAY CYCLES**
Total cycles for the current day.
- **9.4 SERVICE CYCLES**
Displays the programmed service cycle count.
If the count reaches zero, the option to reset will appear.

LCD SETTINGS AND DIAGNOSTICS (CONT.)

10. EXPORT TO USB

(Allows settings and diagnostic data to be exported for review on a smartphone or PC. The thumb drive must be formatted to FAT, FAT16, or FAT32.)

10.1 EXPORT PROCESS

Insert a formatted thumb drive into the USB port to export data and follow the prompt.

EVENT LOG – POSSIBLE FAULTS AND DEFINITIONS

(The event log records up to 50 events, including system faults. Review these entries during diagnostics to identify and correct issues.)

General Notes:

1. Inputs that remain active for more than 5 minutes should be investigated. This may be intentional, but it could also indicate a phantom issue that intermittently holds the gate open or closed.
2. Logged inputs showing ON/OFF changes help diagnose the cause of gate malfunctions.
3. **P/S LINK OFF** and **P/S LINK ON** events indicate intermittent communication issues.
 - o For hard-wired systems, check communication cable connections.
 - o For wireless systems, check for possible sources of interference in the environment.

FAULT DEFINITIONS

- **EXIT IN >5m** – Exit loop input active for more than 5 minutes.
- **SAFE IN >5m** – Safety loop input active for more than 5 minutes.
- **P/S LINK OFF** – Communication between Primary/Secondary operators lost.
- **P/S LINK ON** – Communication between Primary/Secondary operators established.
- **AC PWR OFF** – AC power lost.
- **AC PWR ON** – AC power detected.
- **BATTERY OFF** – Battery power lost.
- **BATTERY ON** – Battery voltage detected.
- **FUSE BLOWN** – Motor fuse blown. Replace fuse on main board.
- **STOP CMD ON** – Stop command input activated, gate stopped. Check FP_DISABLE input.
- **STOP CMD OFF** – Stop command input deactivated.
- **RADIO IN >5m** – Radio input active for more than 5 minutes.
- **EDGE IN ON** – Edge 10K input triggered.
- **CLOSE IN >5m** – Close input active for more than 5 minutes.
- **CLOSE ERD** – Close ERD tripped. Inspect gate and adjust ERD if necessary.
- **OPEN ERD** – Open ERD tripped. Inspect gate and adjust ERD if necessary.
- **PHANTOM >5m** – Phantom loop input active for more than 5 minutes.
- **AC VOLT LOW** – AC voltage drop detected. Inspect main power connections.
- **AC VOLT HIGH** – High AC voltage detected. Check power supply.
- **MOTOR OL** – Motor overload. Check gate hardware and operator capacity.
- **EEPROM ERROR** – Processor error. Replace board.
- **MON-OPEN FLT** – Fault on monitored open input. Check entrapment device alignment/function.
- **MON-CLOSE FLT** – Fault on monitored close input. Check entrapment device alignment/function.
- **FIRE IN >5m** – Fire access input active for more than 5 minutes.
- **OPEN IN >5m** – Open input active for more than 5 minutes.
- **AUX1 OPEN >5m** – Aux1 Open input active for more than 5 minutes.
- **AUX2 OPEN >5m** – Aux2 Open input active for more than 5 minutes.
- **AUX1 CLOS >5m** – Aux1 Close input active for more than 5 minutes.
- **AUX2 CLOS >5m** – Aux2 Close input active for more than 5 minutes.
- **AUX1 PARTIAL OPEN >5m** – Aux1 Partial Open input active for more than 5 minutes.
- **AUX2 PARTIAL OPEN >5m** – Aux2 Partial Open input active for more than 5 minutes.
- **AUX1 FORCE OPEN >5m** – Aux1 Emergency Open input active for more than 5 minutes.
- **AUX2 FORCE CLOSE >5m** – Aux2 Emergency Close input active for more than 5 minutes.
- **AUX1 STOP ON** – Aux1 STOP input activated, gate stopped.
- **AUX1 STOP OFF** – Aux1 STOP input deactivated.
- **AUX2 STOP ON** – Aux2 STOP input activated, gate stopped.
- **AUX2 STOP OFF** – Aux2 STOP input deactivated.
- **MOTOR SF** – Motor sensor fault. Check motor harness connections.
- **STOP-IN ON** – STOP input activated.
- **STOP-IN OFF** – STOP input deactivated.

SL-175DC PRO EMERGENCY RELEASE

Procedures to manually open Gate :

1. Turn operator power "OFF"
2. Push foot pedal down and move to the left to lock pedal in down position
3. Push gate open



WARRANTY AND RECORD

MANUFACTURER'S LIMITED WARRANTY

ALL-O-MATIC INC warrants the SL-175DC PRO gate operator for a period of five (5) years in commercial installations. The SW-375DC PRO will have warranty period of three (3) years in commercial installations. The above operators, within their warranty period, are to be free from defects in circuitry, motor, gearbox and workmanship. This warranty begins from the date of purchase to the original owner. Warrantor will repair or, at its option, replace any device which it finds to require service. This device must be sent to the warrantor at the consumer's expense to:

**ALL-O-MATIC INC.
7658 HASKELL AVE.
VAN NUYS, CA 91406**

The warrantor will return the repaired or replaced unit to the customer at the consumer's expense. Labor charges for dealer service or replacement are the responsibility of the owner. These warranties are in lieu of all other warranties either expressed or implied, and ALL-O-MATIC INC shall not be liable for consequential damage. All implied warranties of merchantability and or fitness for a particular purpose are hereby disclaimed and excluded. This limitation is not valid in jurisdictions which do not allow limitation of incidental or consequential damages or limitation of warranty periods. In order to obtain this policy, please complete the registration card and send it by mail within 30 days of purchasing from ALL-O-MATIC INC. or your installer. If product is not registered, only a one year warranty on all parts will be provided.

CUSTOMERS RECORD

Customer Name _____

Address _____

Purchased from (Installation Co.) _____

Date ____/____/____

Model Number _____

Serial Number _____ - _____

ALL-O-MATIC[®]

MANUAL

