



# 1500 PRO

**FAIL SECURE**  
High-traffic Commercial  
Brushless DC Slide Gate Operator  
The Maximum Level of Gate Control



**5-YEAR WARRANTY**  
PLEASE READ  
WARRANTY POLICY

**TRUE SECURITY... DSP MOTION CONTROL... HIGH PERFORMANCE**  
**SAFETY SENSORS REQUIRED FOR UL 325 2018**



## **MECHANICAL SPECIFICATIONS**

- Max 1500 PRO Slide Gate Operator dimensions (14.5" W x 19" D x 25.5" H) 7.5" chain height
- Heavy-duty direct drive gear box Size 50, 30:1 gear ratio
- ✔ Max 1500 PRO capacity 1500 lbs /50 ft long gate speed 12" per second for class I II, III and IV
- ✔ Independent Opening and Closing speed controls for primary and secondary
- Direct gear drive (no internal chains, belts, or pulleys)
- Corrosion protection with gold zinc coating and electrostatic powder coating
- ✔ Continuous cycle at extreme temperature ranges—overheating not possible
- ✔ Intelligent ramp-up and ramp-down for smooth operation
- Selectable short or long ramp-down
- Shipping weight of Max Slide Gate Operator: Max 1500 PRO (152 lbs)
- ✔ Programmable virtual OPEN & CLOSE limit (Limits auto-set in the event of a total power loss)

## **ELECTRICAL SPECIFICATIONS**

- ✔ Electronic Release: Jog switch at front cover sliding window
- ✔ Brushless DC motor equivalent to 1/2 HP AC motor
- ✔ Programmable gate speed controls, 16 selectable speeds
- ✔ Automatic gate position reset requires optional magnets and sensors or when using virtual limits, positive stops on both gate directions
- Modular system designed for ease of service
- Switchable 115/230 voltage selection
- Adaptive DSP control for advanced brushless DC motion control
- ✔ Real time performance analyzer and event log (OBD PORT and Black Box) 8000 events including the history of error failure
- ✔ LCD display that report past and recent errors
- Low voltage wiring capabilities for remote power up 500 ft (no battery needed)
- ✔ 'Solar Ready' battery module with built-in advanced solar regulator
- ✔ Intelligent power management system with energy saver mode
- ✔ Built-in 12V DC and 24V DC outputs
- Gold contact input connections and automobile grade connectors
- Selectable open timer 0 to 60 seconds with 'timer-off' option
- ✔ -4F to 165F (-20C to +74C) operational temperature range including battery performance without needing a heater
- Robust lightning protection up to 20K Volts and 10K Amps on all inputs and outputs (44 channels) including loop detector input connections

✔ = Unique to Max Slide Gate Operator Series

- ✔ Motor overcurrent safety shut-off for additional protection
- ✔ This operator includes a battery backup module providing on average 200 cycles in case of power failure
  - Three modes of selectable battery backup functions
  - State machine designed electronics with ultra-fast microprocessor
  - On-board three button station

## ***SECURITY SPECIFICATIONS***

- ✔ High-traffic intuitive loop management system for better security
- ✔ Advanced security features with built-in audible and remote alarms
  - Magnetic lock control relay outputs with selectable delay times
- ✔ Tamper-alert relay output triggers "ON" if gate is forced open
- ✔ Audible alarm if gate is tampered with or ERD is triggered for higher security
- ✔ Gate partial open recorder. Programmable inputs allow partial open cycles for high-traffic gates while providing complete open cycles for emergency vehicles
  - Lockable cover with key-lock release to prevent intruders and vandalism
- ✔ Built-in transaction buffer for high security 8000 events as well as error messaging file
- ✔ Gate status outputs for gate monitoring
- ✔ Advanced anti-tailgate feature provides higher security
- ✔ Optional Chain Drop Sensor detects unauthorized chain drops when using magnets option
- ✔ Fire Department Compliance allows gate to auto-open upon loss of AC power or battery depletion

## ***SAFETY SPECIFICATIONS***

- ✔ Adaptive obstruction sensor for much better gate safety system. 16 selectable sensitivity settings
- ✔ UL 325/991 compliant Class I, II, III, and IV. CSA approved
- ✔ Dynamic magnetic brake system stops the gate immediately to prevent damage to obstructions
  - Built-in advanced entrapment protection and alarm output
  - Built-in "gate-in-motion" alarm for industrial applications
- ✔ Optional normally close or 10K safety inputs (most safety inputs in the industry)

✔ = Unique to Max Slide Gate Operator Series

OPTIONAL

# MAX CLOUD APP

Affordable and unique APP control solution for the residential and commercial gate operator market.  
Compatible with Max Operators except Phantom F6 and 2000 Plus



  Smartphone · Tablet



## VIRTUAL TRANSMITTER:

- To open or close a gate from anywhere in the world - via Max Cloud App
- Supports >10,000 virtual transmitters



## QUICK & RELIABLE APP COMMANDS:

- App uses a dedicated cloud server to issue gate OPEN & other commands within a second.
- Cellular data connectivity is more reliable than WiFi due to range limitations.
- Cloud based app does not use text messaging which has unpredictable delays.



## MANAGE GATE SITES USING MAX CLOUD APP:

- Add Admin users that can manage the gate site database.
- Add users with optional time restrictions
- Issue temporary Guest Passes for visitors
- With Max Keypad option: Program keypad key codes, Wiegand key codes for card readers, radio receivers and transponders with time restrictions
- Setup Auto Open / Close Timer for Max operators
- Retrieve Event log
- Retrieve Operator Diagnostics info: Error log



## MULTIPLE GATE SITES SUPPORTED BY MAX CLOUD APP

- Gate sites can be controlled and monitored individually via app



## SIMPLE AND SECURE APP LOGIN :

- Securely login to app using Cloud based authentication code. This avoids the need to remember passwords



## USER FRIENDLY MENUS:

- Easy to program App Users & Guest passes with time restrictions.
- All programming is done on Max Cloud App - not a website portal

# MAX 1500 PRO

## High-traffic Commercial Brushless 24V DC Slide Gate Operator

- Continuous duty cycle
- Gate speed 12" per second
- 5-year warranty
- 1-year warranty on Battery
- Gate capacity 50 ft long 1500 lbs
- UL 325 class of operation I, II, III, IV
- Built-in battery backup; providing a minimum of 100 cycles
- Includes cover door
- Includes a 25 ft nickel plated chain & brackets

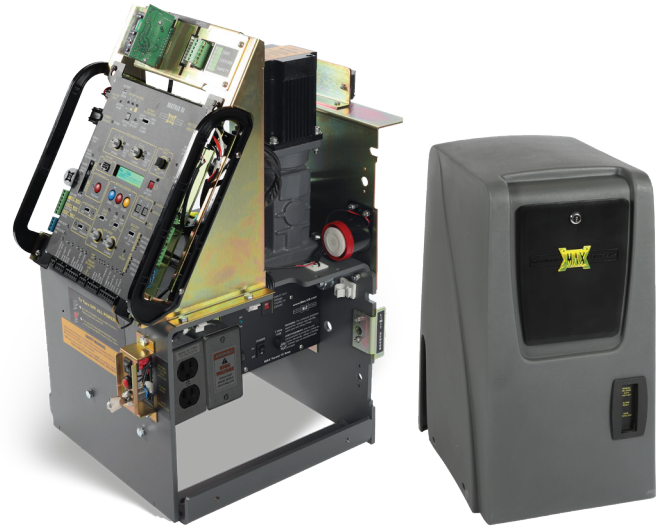

**Input AC Power/Amps** - Switchable: 115V AC / 6 Amp, Single Phase or 230V AC / 2 Amp, Single Phase



**OPTIONAL**

## **Heavy Duty Steel Cover for Max 1500 PRO**

- 15 gauge steel, gold zinc plated and powder-coated, heavy duty hasp for secure locking
- Sold only with purchase of any slider
- Special order, not sold separately

# MAGNETIC LIMIT SENSING TECHNOLOGY

The typical gate operator tends to lose its set position after a period of time, but Max Sliders employ technology that eliminates this problem.

The open/close limit placement for the Max Slide Operator works using magnetic sensing technology. Limit Sensor Activators (magnets) are placed on both sides of the chain to indicate the gate's "open" and "closed" position. The magnets trigger the sensors when they align.

The advantage of this method of limit sensing includes precise position sensing regardless of chain slack as well as eliminating many mechanical moving parts.

Max Slide Gate Operators' magnetic sensing technology is not the operator's sole method of determining gate limit positions. Once the open/close positions are set via Limit Sensor Activators, the primary method the operator recognizes open/close positions is with its Brushless DC Hall Effect magnetic sensing.

Hall Effect sensors, which reside in the motor, identify over thirty precise rotational positions during every inch of gate travel, utilizing the Limit Sensor Activators as an additional resource. Simultaneously employing the Hall Effect with the Limit Sensor Activators ensures the gate to open/close in the same position it was set to for years to come.

## OPTIONAL FEATURE

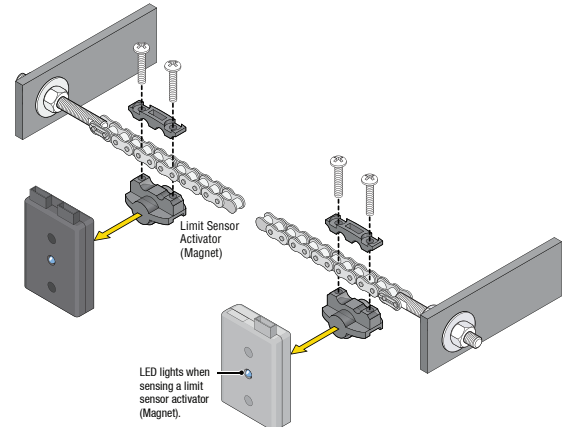
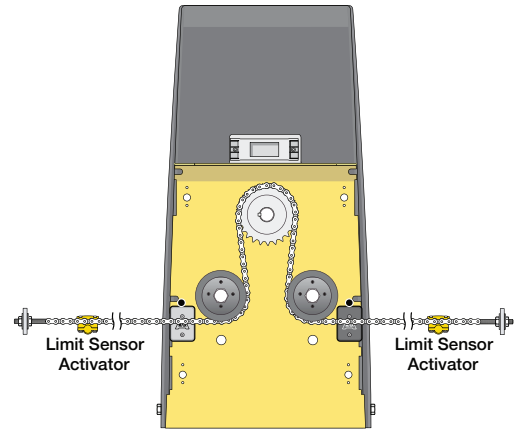

## JOG SWITCH

- If the Battery Backup is set to one time open or leave open, the operator's braking system will be released allowing the gate to be pushed back in case of catastrophic failure.
- The Electronic Gate Open / Close is used to disengage the operator's braking system for 15 minutes with local key or remote key-switch wired into the jog inputs on the motor controller.

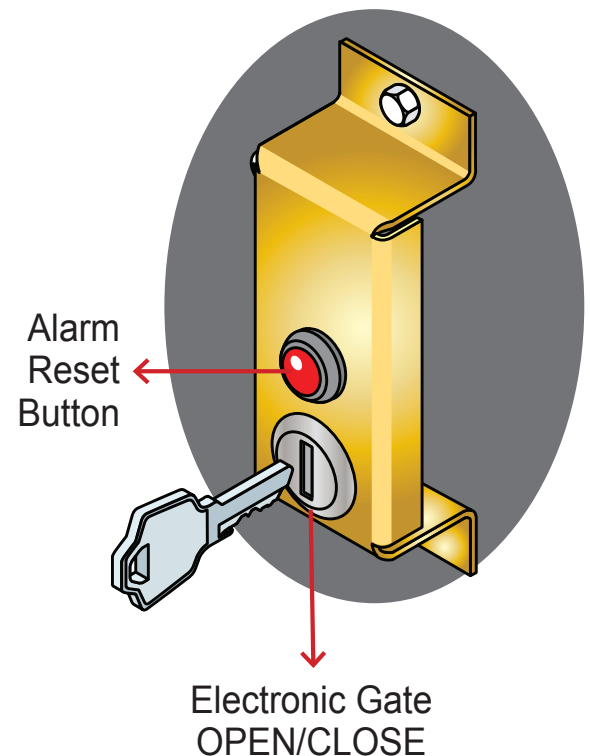

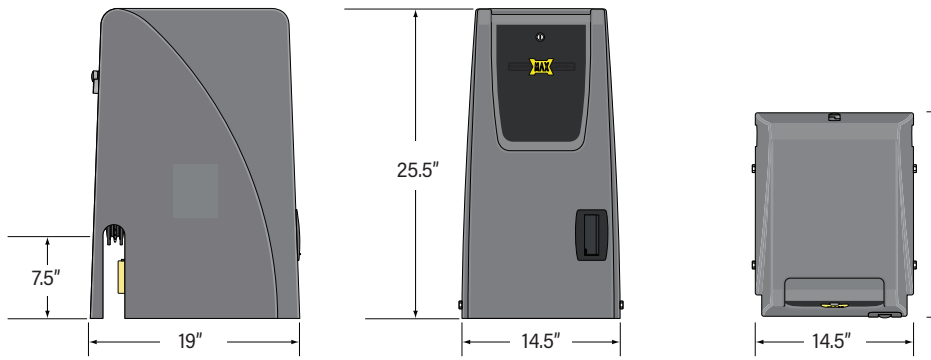

Brushless DC Motor is Equivalent to 1/2 HP AC Motor  
 6 Million Cycle  
 35,000 hours of Life Expectancy  
 Integrated Hall Effect Encoder

Heavy-duty Gear Box  
 Constant Lubrication  
 Using Special Gear Oil

Advanced Matrix III  
 Controller

Heavy-duty 1/4\"/>

AGM Battery Back-up  
 Can Operate the Gate for a  
 Minimum of 100 Cycles





## GEARBOX

The Max Slide Gate Operator Series implements 3 various gear boxes depending on the model.

**Max 1500 PRO: Size 50, 30 to 1, High Efficiency, Heavy-duty Cast Iron Gearbox.**

The Max 1500 PRO gate operator gearbox is highly efficient; producing maximum torque, maintaining a low amperage draw by reducing resistance, and providing super silent operation.

The rugged cast iron housing, bronze gears, and double sealed heat-treated solid shafts have been designed by a team with over 40 years of experience in the gearbox industry. High speed ball bearings and a synthetic oil bath keep the operator functioning flawlessly through extreme temperature ranges without need for belts, chains or pulleys—which are subject to wear—raising maintenance issues. We invite you to compare Maximum Controls' gearboxes to any other gate operator manufacturer.

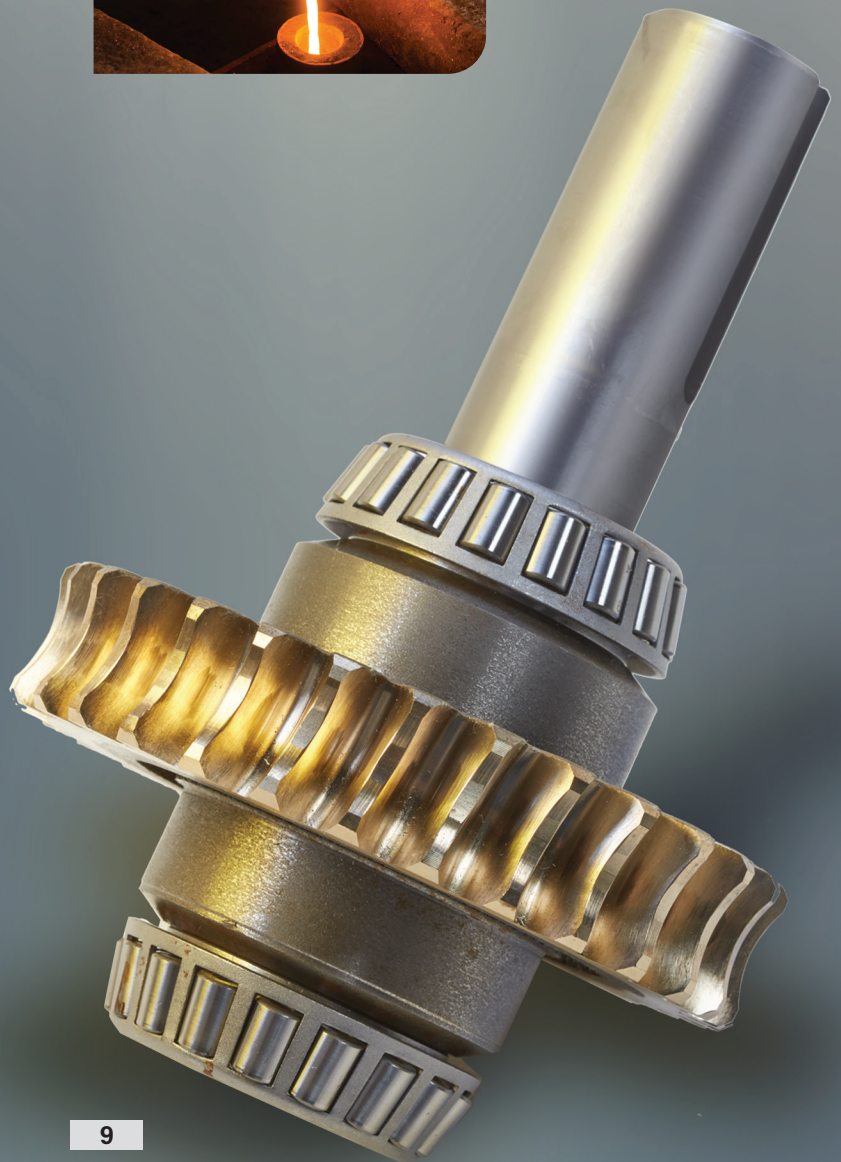

## BRUSHLESS DC MOTOR

The brushless DC motor in the Max 1500 PRO Slide Gate Operator uses "Hall Effect" magnetic sensing to identify precise rotational positions during gate movement; that's over 30 samples per inch of gate travel. Using this positional feedback, intelligent ramp-up and ramp-down of the gate speed is employed to minimize stress on all mechanical components.

Hall Effect Sensors are utilized to identify the position of the gate at any given moment, synchronizing the gates to open and close at the same speed. This technology is combined with a dynamic magnetic brake system which stops the gate instantly when colliding with an obstacle.

Our brushless DC motors can withstand and operate in extreme high temperatures up to 165F (+74C); this surpasses any other motor technology we know of in the market today.

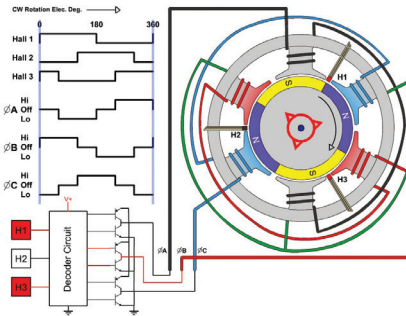

The Max brushless DC motor's torque is equivalent to a 1/2 HP (Max 1500) and can operate approximately 35,000 hours, which is about 6 million cycles. This means the motor can last for decades to come and is the reason Maximum stands behind our motors with a 5-year warranty.

Brushless motors controlled by DSP is the same motor technology used in advanced robotics for automobile assembly.



## MOTOR CONTROL TECHNOLOGY

Maximum Controls' brushless DC motor controller enables precision movement that traditional brushed motors cannot replicate. For example, with our motors there is not over-coasting. This ability is crucial in bi-parting slide gates on the same track, as well as catching posts or columns that can't be avoided.

Another advantage of precise gate control is the ability to stop the gate instantly. In an emergency situation, this is critical. When a safety edge is struck, stopping the gate instantly to reduce risk of injury or damage to equipment is imperative. Our motor control technology is absolutely the most advanced on the market.

## **ADVANTAGES OF BRUSHLESS DC MOTOR**

FEATURE	BRUSHED DC MOTORS	BRUSHLESS DC MOTOR MAX
Commutation	Mechanical	Electrical
Maintenance	High	Very Low
Electronic Noise EMI	High	Super Low
Life	Short	Much Longer 6,000,000 Cycles
Speed/Torque Characteristics	Moderately Flat	Flat (Enables Operation at All Speeds)
Efficiency	Medium	High
Motor Speed	Limited Speed Control	Variable Speed Control
Audible Noise	High at High Speeds Because of Brushes	Super Quiet
Drive Complexity	Inexpensive	Advanced DSP Control
Loss of Torque Due to Aging	Yes	No
Energy Consumption	Higher	Lower
Magnetic Hall Sensors	No	Yes (30 samples per inch of gate travel)

## POWER SUPPLY

Max Slide Gate Operator's power supply utilizes a 15 Amp toroid and power management board. The power supply is designed such that it is not overstressed under any extreme load or temperature conditions. The power supply input accepts 115 or 230 voltage via selection switch. During gate operation, the battery is not utilized while AC is present, thus preserving the life of the battery.

### **Input AC Power/Amps -**

Switchable: 115V AC / 6 Amp, Single Phase  
or 230V AC / 2 Amp, Single Phase

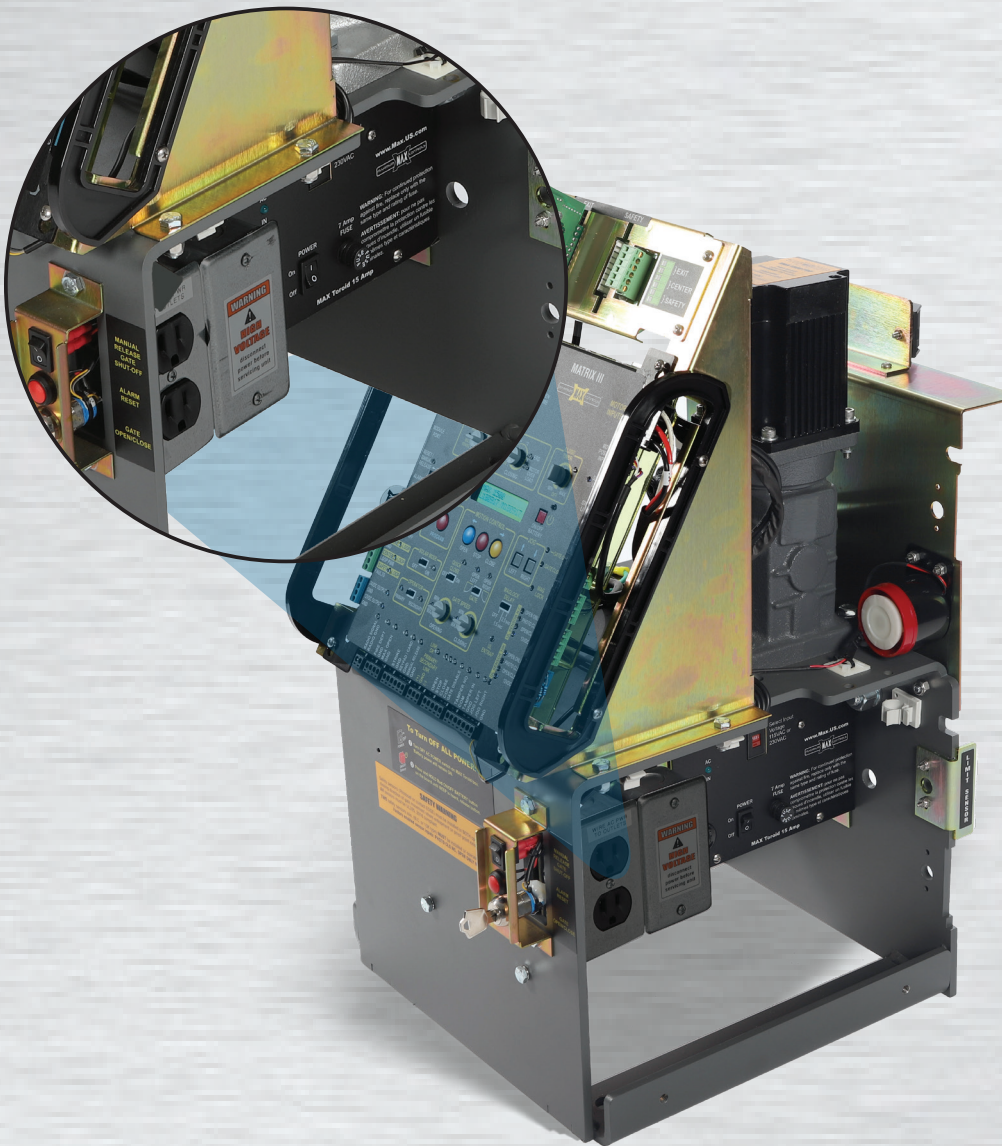

# BLACK BOX, USB DIAGNOSTICS

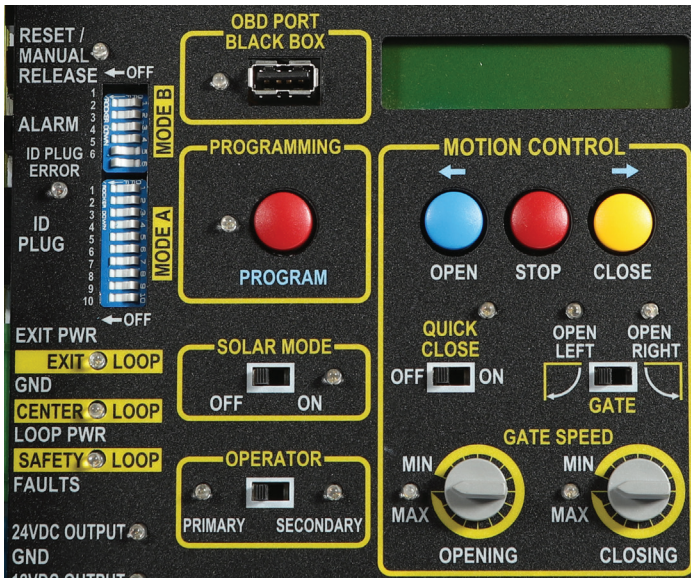

One of the primary goals of the Max 1500 PRO is to provide the most secure, easiest to maintain gate operator with higher gate speed motion and advanced loop management.

Max 1500 PRO uses non-volatile memory to continuously log performance characteristics and input/output events. A service technician can access this data via USB port to download the event history, quickly diagnosing complex or intermittent problems that traditionally have been very difficult to isolate and repair.

By plugging in a USB thumb drive into the USB port, all the diagnostic history will download, working as a "Black Box" to diagnose what occurred. The event history is stored as a .TXT document which can be emailed to the factory for, if necessary, on-site diagnosis. The .TXT file is a log of the most recent 8000 events reported by each module to the central logger.



## ADVANCED SECURITY FEATURES:

### Tamper Alert and Gate Disable

Maximum Controls' patented Tamper Alert triggers a relay when an unauthorized entry attempt by chain-drop or gate movement has occurred. It's simple, if someone cuts the chain the magnet falls off the sensor and the Tamper Alert relay activates. The relay command can trigger an audible alarm, a burglar alarm system or other devices with relay inputs such as a security cameras.

Unique to all Maximum Controls gate operators is the Gate Disable feature which disables normal open commands from devices like a keypad box or exit loop. Gate Disable prevents someone from breaking into a property by tampering with the inputs in a keypad box or triggering the exit loop with a piece of metal to open the gate. The Gate Disable feature is useful when a gated area needs to be secured from all BUT emergency vehicles and/or other authorized vehicles. When Gate Disable is turned ON it gives the occupants 3 minutes BEFORE arming, allowing enough time to leave the property. If there is an attempt to open the gate in an unauthorized manner, the gate will not open but will sound an alarm and trigger the Tamper Alert relay.

**GATE DISABLE** prevents breaking into a keypad box and trying to trigger the wires to get the gate to open.



**GATE DISABLE** prevents trying to trigger the exit loop to get the gate to open.

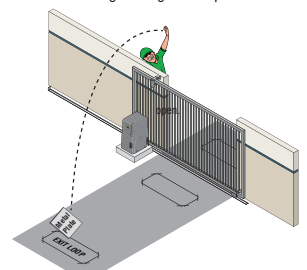

**EXIT LOOP**  
Gate Disable can be activated with a key-switch or a 7-day timer. Examples for using Gate Disable would be: during vacation time at a residential home or when a business is closed and no one is available to monitor the property.

# CONTROL FEATURES AND CONNECTIONS

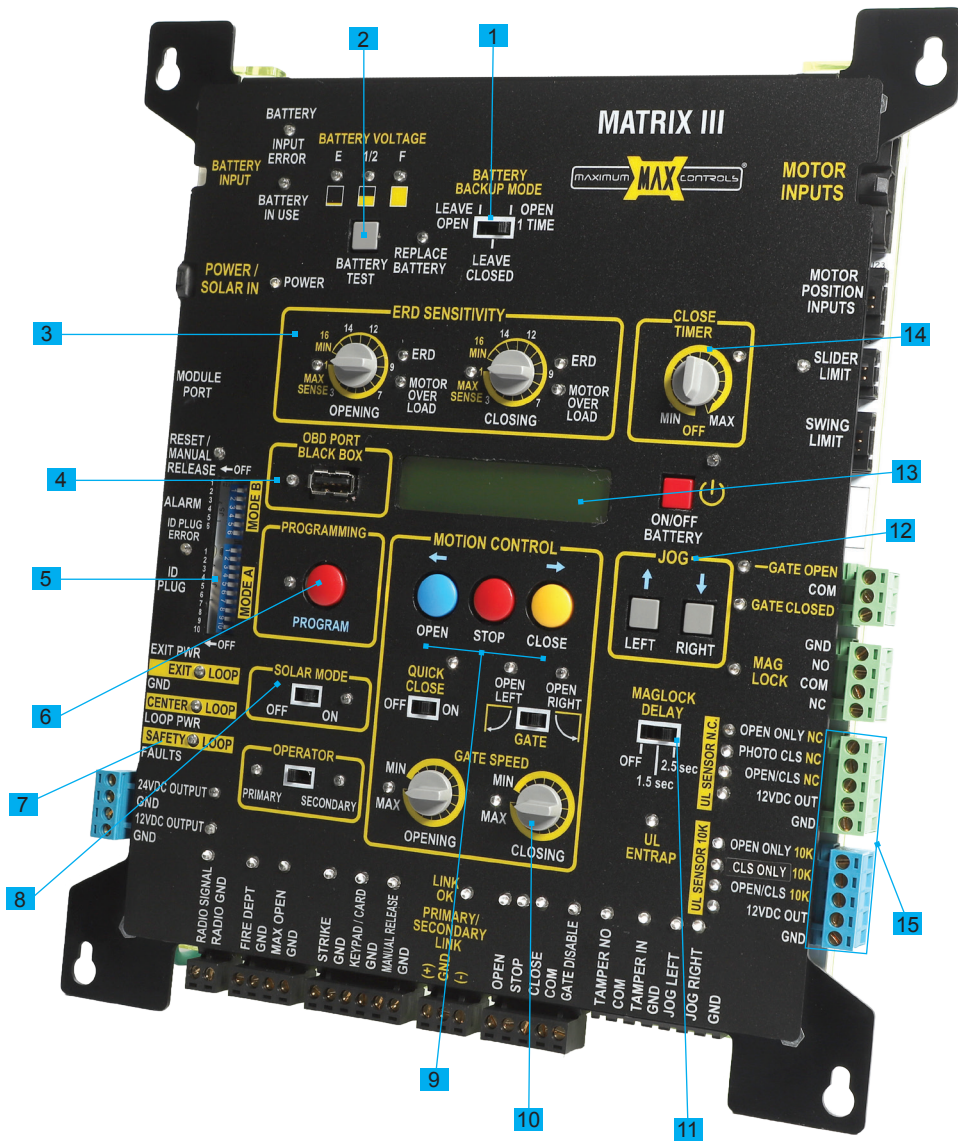

1. Battery Backup Mode Switch
2. Battery Test Switch
3. ERD Sensitivity
4. OBD Port
5. DIP Switches
6. Program Button
7. Loop Status
8. Solar Mode Application
9. Motion Control Buttons
10. Closing Gate Speed
11. Maglock Delay
12. Jog Open/Close
13. LCD Display
14. Close Timer Switch
15. Safety Sensor Ports for both N.C type and 10k type sensors. Up to 12 sensors support 2018 compliant. 10k sensor inputs allow direct wiring to 10k edges and require less wiring for 10k wireless edge receivers.

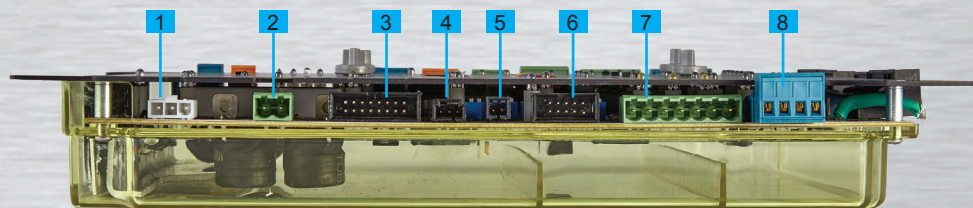

- |                      |   |
|----------------------|---|
| 1. Battery Input     | 5. UL Alarm                                     |
| 2. Power/Solar Input | 6. ID Plug                                      |
| 3. Module Port       | 7. Loop Rack Input                              |
| 4. Reset             | 8. 12V DC & 24V DC Limited Current Power Output |

# LIGHTNING PROTECTION



The Max Slide Gate Operator Series offers the most robust lightning protection available in the industry. The Max Slide Gate Operator Series protects all peripheral inputs, loop inputs, power inputs, relay outputs, and all communication lines (over 44 channels of protection) in 1/1,000,000,000 of a second. With special emphasis on power supply protection, the Max Slide Gate Operator Series is guaranteed to withstand any lightning hit more than 50 feet away; truly protected like no other operator in the world.

# **Maximum Controls LLC Warranty and Return Policy Max 1500 PRO**

## **Section I Coverage**

- a. 5-Year on all components
- b. 1 year on batteries
- c. 1 year on idler sprockets

## **Section II Not Covered**

- a. Damages due to vehicular strike.
- b. Damages due to water or liquid.
- c. Damages due to fire.
- d. Damages due to direct lightning.
- e. Damages due to extreme high wind.
- f. Damages due to vandalism.
- g. Damages due to negligence, i.e. leaving the cover off in the rain, improper wiring of AC or peripheral systems.
- h. Damages due to product misuse, i.e. gate and operator combination mismatch, i.e. heavy gate paired with low capacity gate operator.
- i. Damages due to unauthorized product modification or attempted repair.

## **Section III RMA Shipping Policy**

- a. Maximum Controls LLC will pay for return shipping via standard ground UPS or USPS FOB CA on all RMA's within one year of Distributor's purchase
- b. Any form of "Expedited Shipping" on any RMA will be paid by Distributor

## **Section IV Product Returns**

- a. Products must be in original, resellable condition with all warranty information, manuals, and original packaging.
- b. A re-stock fee of 10% will be charged on all returned products.
- c. All returned products must reference a Maximum Controls RMA number or it will be refused.
- d. Maximum Controls is not responsible for freight charges associated with returned merchandise.

**NOTE: Products purchased online from unauthorized distributors will not be covered by our warranty.**



