

AIPHONE®

GT SYSTEM

Standard & Expanded System

INSTALLATION MANUAL

The following manuals (in multi languages) of the GT system are also available from our website <https://www.aiphone.net/>.

* The site can be accessed directly by reading the QR code on the right.

- Operation manual
- Installation manual
- Setting manual
- Quick start installation guide
- Aiphone GT Setup Tool for Windows

[QR code]



Thank you for selecting Aiphone for your communication needs. Please read this manual carefully before installation, and keep this in a safe place for future reference.

The illustrations used in this manual may differ from the actual product.

PRECAUTIONS

 Prohibited

 Do not dismantle unit

 Keep unit away from water

 Be sure to follow the instruction

WARNING

(Negligence could result in death or serious injury.)

1. Do not disassemble or modify the station. This may result in fire or electrical shock.
2. Do not install two power supplies in parallel to a single input. This may result in fire or electrical shock.
3. Do not connect any terminals on the station directly to an AC power line. This may result in fire or electrical shock.
4. Use the Aiphone power supply specific for use with the system. This may result in fire or malfunction.
5. Do not use with a power supply rated above the specified voltage. This may result in fire or electrical shock.

CAUTION

(Negligence could result in injury to people or damage to property.)

1. Do not install or connect the station with the power on. This may result in electrical shock or malfunction.
2. Make sure the wiring is correct and there are no wiring shorts before switching on the station. This may result in fire or electrical shock.
3. Install in a place where the station will not get easily bumped. This may result in injury.
4. Do not install the station in a place subject to frequent vibration or impact. This may result in injury.
5. When testing chime volume and ringtone volume, do not hold the handset close to your ear. May cause harm to the ear if a sudden loud noise is emitted.
6. Do not put your ear close to the speaker when using the station. May cause harm to the ear if a sudden loud noise is emitted.

Precautions for mounting

1. Observe the following restrictions for mounting entrance stations.
 - When cleaning the wall with a high-pressure washing machine, avoid to spray on the entrance station.
 - Do not mount the entrance station so that it faces obliquely upward. Rain water or moisture may penetrate the station and damage the unit.
 - Do not block the bottom of entrance station by caulking.
2. Installing the device in the following locations could cause malfunction:
 - Locations under direct sunlight
 - Locations near heating equipment
 - Locations subject to liquid, iron filings, dust, oil, or chemicals
 - Locations subject to moisture and humidity extremes
 - Locations where the temperature is quite low
 - Locations subject to steam or oil smoke
 - Sulphurous environments
 - Locations close to the sea or directly exposed to sea breeze
3. Installing the station in the following locations as is may affect the clarity of the image:
 - Where lights will shine directly into the camera at night time
 - Where the sky fills much of the background
 - Where the background of the subject is white
 - Where direct sunlight is present
4. In 50Hz regions, if a strong fluorescent light enters directly into the camera, it may cause the image to flicker. Either shield the camera from the light or use an inverter fluorescent light.
5. For wiring, separate them for audio/video and door release and keep them more than 10cm (3-15/16") away from each other.
6. If existing wiring is used, the device may not operate properly. In that case, it will be necessary to replace the wiring.
7. Do not use an impact driver to fasten screws. Doing so may cause damage to the device.
8. Avoid installing the master monitor station in concave space of a wall to prevent disconnection of communication.

General Precautions

1. Install low-voltage lines at least 30cm (12") away from high-voltage lines (AC100V-240V), especially inverter air conditioner wiring. This may result in interference or malfunction.
2. When installing or using the station, give consideration to the privacy rights of subjects, as it is the responsibility of the system owner to post signs or warnings in accordance with local ordinances.
3. Do not install the unit in the ceiling or on the floor. Doing so would prevent maintenance inspections and repairs from being carried out. This may result in malfunction.
4. The system settings file is required for post-installation maintenance and service. The setting file must be given to the customer.

Notices

- If the station is installed in an area with an extremely strong electrical field, such as in the vicinity of a broadcasting station, it may create interference and cause a malfunction.
- When warm indoor air flows into the unit, dew condensation may be caused by a temperature difference between indoors and outdoors. It is recommended to cover openings on the unit such as cable incoming holes to avoid condensation.
- If the station is used in areas where there are business-use wireless devices such as a transceiver or mobile phones, it may cause malfunction.

Table of Contents

PRECAUTIONS	2
1 SYSTEM CONFIGURATIONS	
1-1 Standard system configuration & capacity	4
1-2 Expanded system configuration & capacity.....	5
1-3 Residential/tenant station configuration.....	6
1-4 Lift control system configuration (for expanded system only).....	9
1-5 Wiring distance	10
2 COMPONENTS	
2-1 Entrance station (modular type).....	14
2-2 Entrance station (all-in-one type).....	16
2-3 Bus control unit etc.	16
2-4 Residential/tenant station, sub residential/tenant station	17
2-5 Door station.....	18
2-6 Guard station.....	18
2-7 Lift control adaptor	18
3 MOUNTING	
3-1 Mounting locations	19
3-2 Wi-Fi installation requirements GT-1C7W-L/GT-1C7W only	20
3-3 Cable	20
3-4 Mounting positions and image view area	21
3-5 Entrance station (modular type).....	22
3-6 Entrance station (all-in-one type).....	24
3-7 Bus control unit, 4-way video junction unit, lift control adaptor and power supply	25
3-8 Residential/tenant station	26
3-9 Door station (for residential/tenant station)	30
3-10 Guard station.....	31
4 WIRING	
4-1 Standard system	32
4-2 Guard station.....	34
4-3 Entrance station.....	35
4-4 Residential/tenant trunk	38
4-5 Expanded system	46
4-6 Lift control system (for expanded system only)	48
4-7 Option connector.....	49
5 SETTINGS	
5-1 Switch settings	51
5-2 Switch settings (for residential/tenant stations only).....	54
6 CHECK FOR INSTALLATION	
6-1 Finding a proper "grounding point" for power supply.....	55
6-2 Checking "ground fault" with tester.....	56
REGULATIONS	57
WARRANTY	58

1 SYSTEM CONFIGURATIONS

1-1 Standard system configuration & capacity

Outline of standard system

* Refer to section 4 "WIRING" for details about wiring and connection.

This system is constructed using 2 wires for audio and 2 wires for video and requires minimal work for installation. A maximum of 6 video trunk lines can be used from the video bus controller and audio signal lines use a distribution point from the bus controller. Audio systems can also be configured.

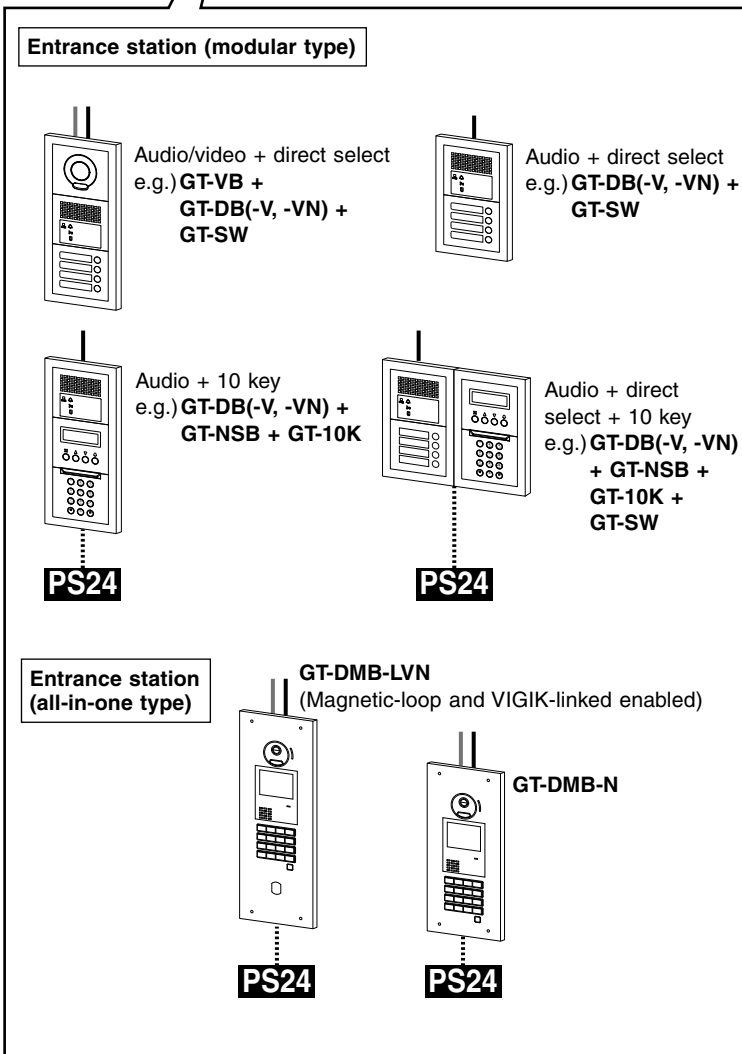
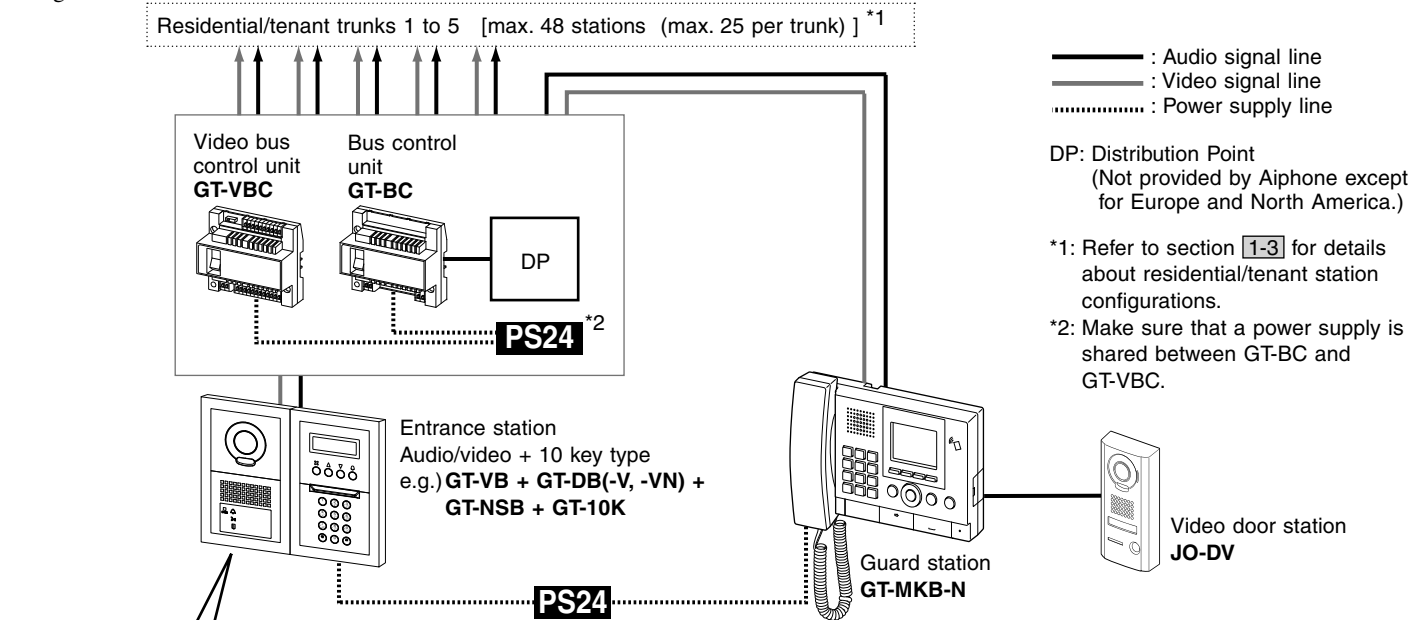

Device	Capacity
Entrance station	Max. 5 (max. 3 per trunk from the DP) *3 *4
Guard station (GT-MKB-N)	Max. 2
Residential/tenant station	Max. 48 (max. 25 per trunk from the DP) *5
Residential/tenant stations in the same residence/tenant	Max. 4 *6
4-way video junction unit (GT-4Z, see section 1-3.)	Max. 6 per residential/tenant trunk
Bus control unit (GT-BC)	1 required
Video bus control unit (GT-VBC [STD])	Max. 1
Sub residential/tenant station (GT-2H-L, GT-2H)	Max. 3 (connectable to the residential/tenant station GT-2C-L or GT-2C only)

- *3: If GT-DB-V, GT-DB-VN or an external door release button is connected to an entrance station that includes GT-SW, a maximum of 3 entrance stations can be connected to the system.
- *4: Up to 3 entrance stations can be connected per audio signal line from the DP. If GT-DB-V or GT-DB-VN is used in an entrance station, the maximum number of entrance stations is 2.
- *5: The maximum is 100 stations with GT-1D only. (GT-1D: Max. 50 stations per trunk)
- *6: Max. 4 under the following conditions only:
- GT-1A or GT-1D × Max. 4
 - GT-1C7(-L) × 1 + GT-1A or GT-1D × Max. 3
 - GT-1M3(-L) × 1 + GT-1A or GT-1D × Max. 3
 - GT-1M3(-L) × 2 + GT-1A or GT-1D × Max. 2
 - GT-2C(-L) × Max. 4
 - GT-1C7W(-L) × Max. 4 (Register a wireless LAN router to only one GT-1C7W(-L) in the same residence/tenant.)

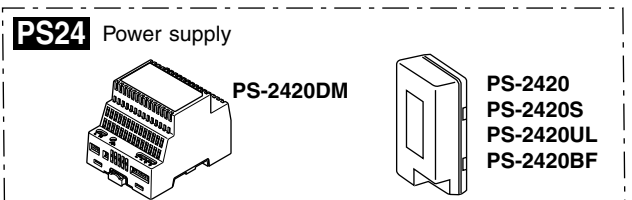

1-2 Expanded system configuration & capacity

The wiring of the sub trunk line is the same as the standard system.

* Refer to section 4 "WIRING" for details about wiring and connection.

— : Audio signal line
 — : Video signal line
 : Power supply line

DP: Distribution Point
 (Not provided by Aiphone except for Europe and North America.)

*1: Refer to section 1-3 for details about residential/tenant station configurations.

*2: Make sure that a power supply is shared between GT-BC and GT-VBC. Also, a power supply must not be shared between trunk lines (including sub and common trunk lines).

*3: Make sure that a power supply is shared between GT-BCXB-N and GT-VBC.

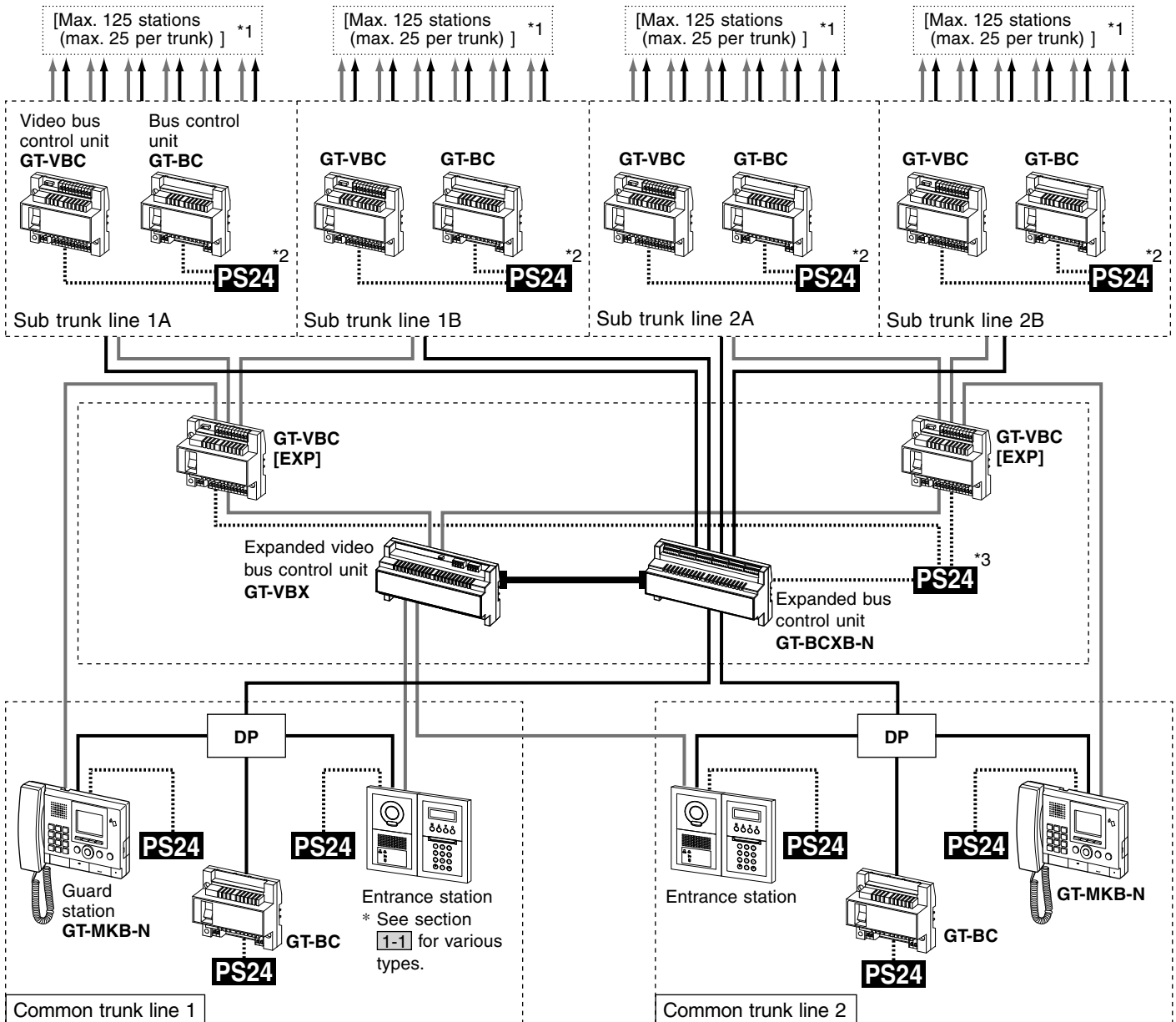

PS24 Power supply

PS-2420DM

PS-2420

PS-2420S

PS-2420UL

PS-2420BF

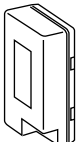
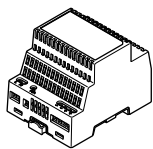

Device	Capacity
Entrance station	Max. 16 (max. 8 per common trunk 1 & 2) *4
Guard station (GT-MKB-N)	Max. 4 (max. 2 per common trunk line 1 & 2)
Residential/tenant station	Max. 500 *5
Residential/tenant stations per sub trunk line	Max. 125 (max. 25 per trunk)
Residential/tenant stations in the same residence	(Same as standard system)
Sub residential/tenant station (GT-2H-L, GT-2H)	(Same as standard system)
Bus control units per common trunk line (GT-BC)	1 required
Bus control units per sub trunk line (GT-BC)	1 required

*4: Up to 3 entrance stations can be connected per audio signal line from the DP within common trunk line 1&2. If GT-DB-V or GT-DB-VN is used in an entrance station, the maximum number of entrance stations is 2.

*5: This includes guard stations connected to the entrance stations by the Hand-shaking link setting.

1-3 Residential/tenant station configuration

For wiring from the control units to each residence/tenant, GT-4Z wiring method, loop wiring method, or GT-1Z wiring method is possible.

NOTE: Mixing different wiring methods on the same trunk line is not allowed.

— : Audio signal line
 — : Video signal line

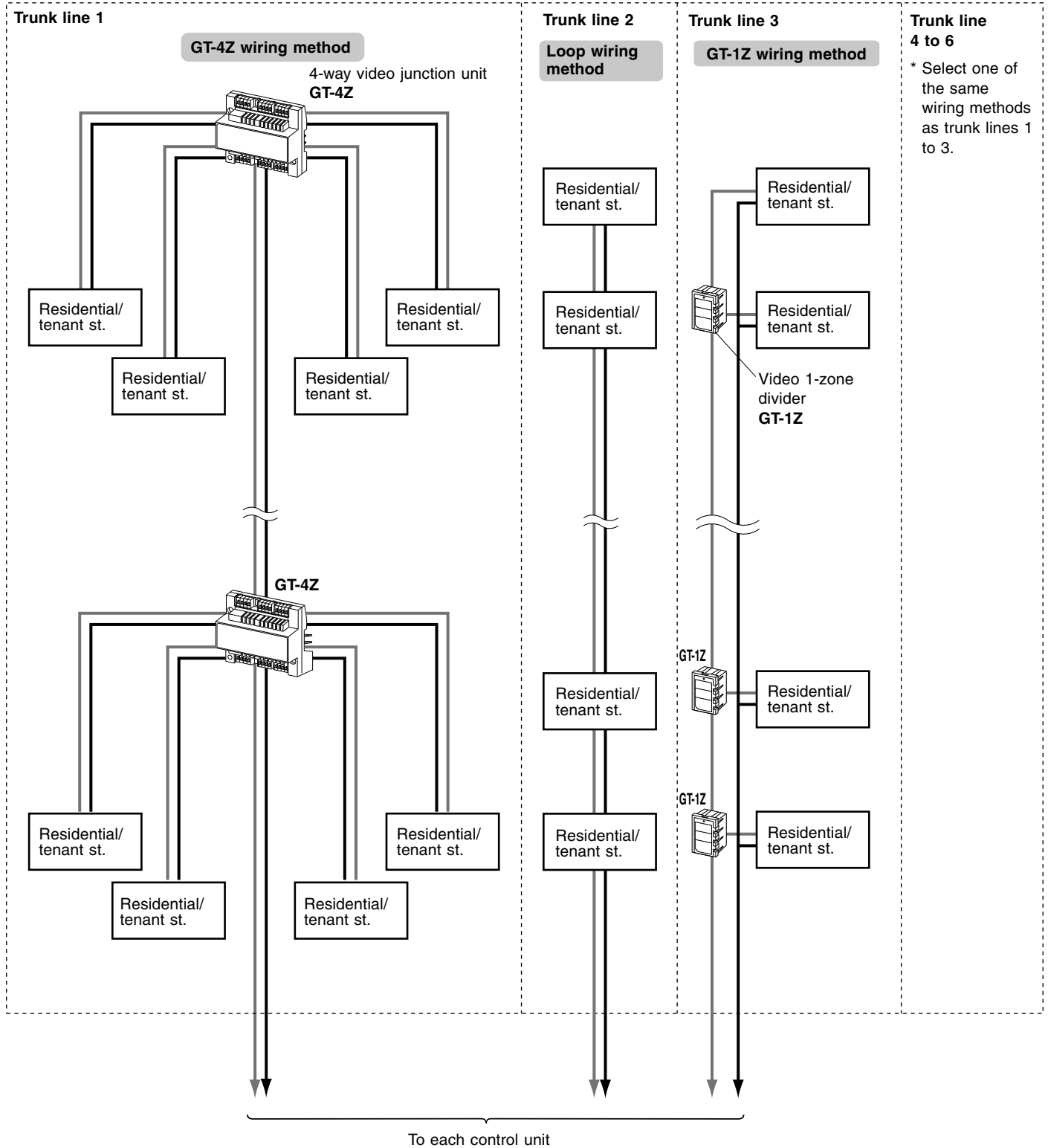

Trunk line 4 to 6
 * Select one of the same wiring methods as trunk lines 1 to 3.

Residence/tenant (for GT-2C-L or GT-2C)

..... : Power supply line

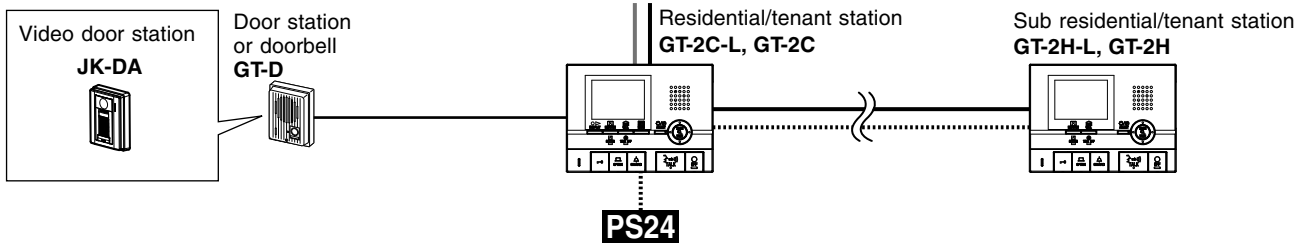

Power supplies

[When sub residential/tenant stations are connected]

One power supply can be used to power 2 residences/tenants if sub stations are used.

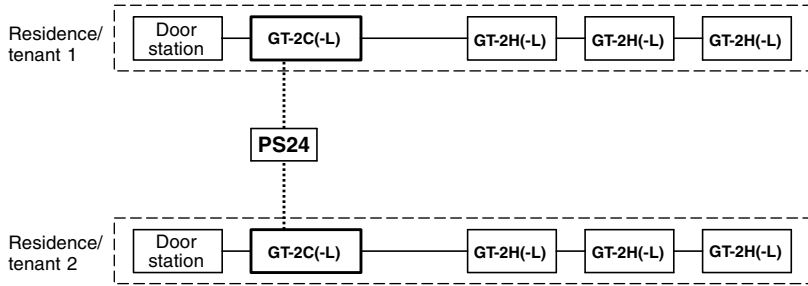

[When sub residential/tenant stations are not connected]

One power supply can be used to power up to 4 residences/tenants if no sub stations are used.

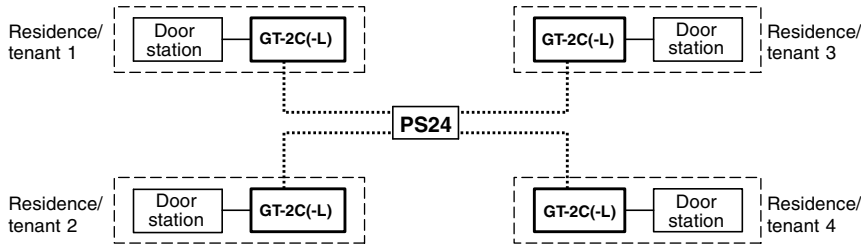

Residence/tenant (for GT-1C7, GT-1C7-L, GT-1M3, and GT-1M3-L)

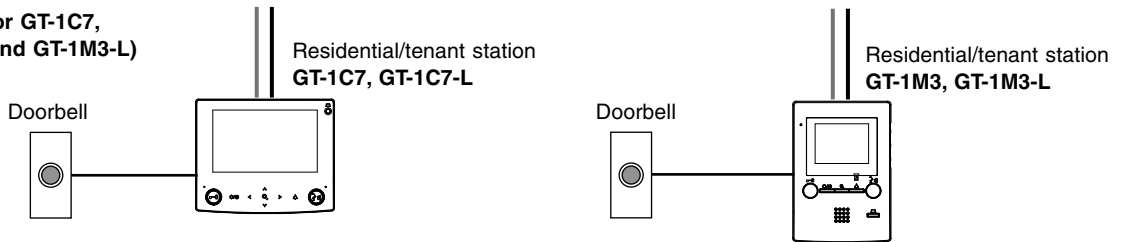

Residence/tenant (for GT-1C7W-L or GT-1C7W)

..... : Power supply line

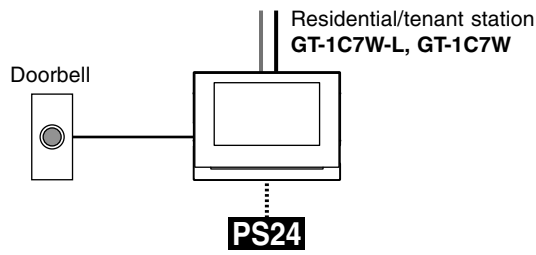

Power supplies

One power supply can be used to power up to 4 residences/tenants.

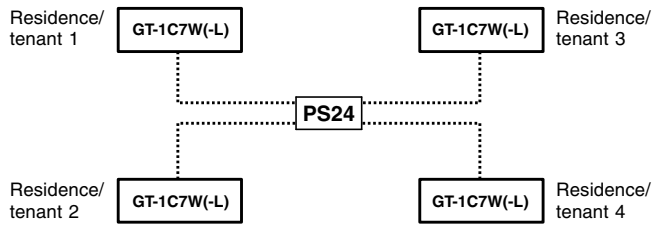

Residence/tenant (for GT-1D and GT-1A)

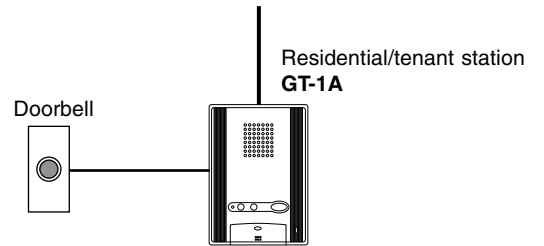
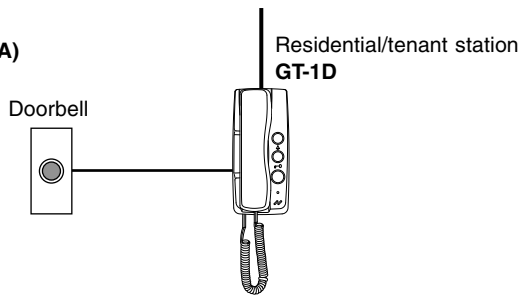

1-4 Lift control system configuration (for expanded system only)

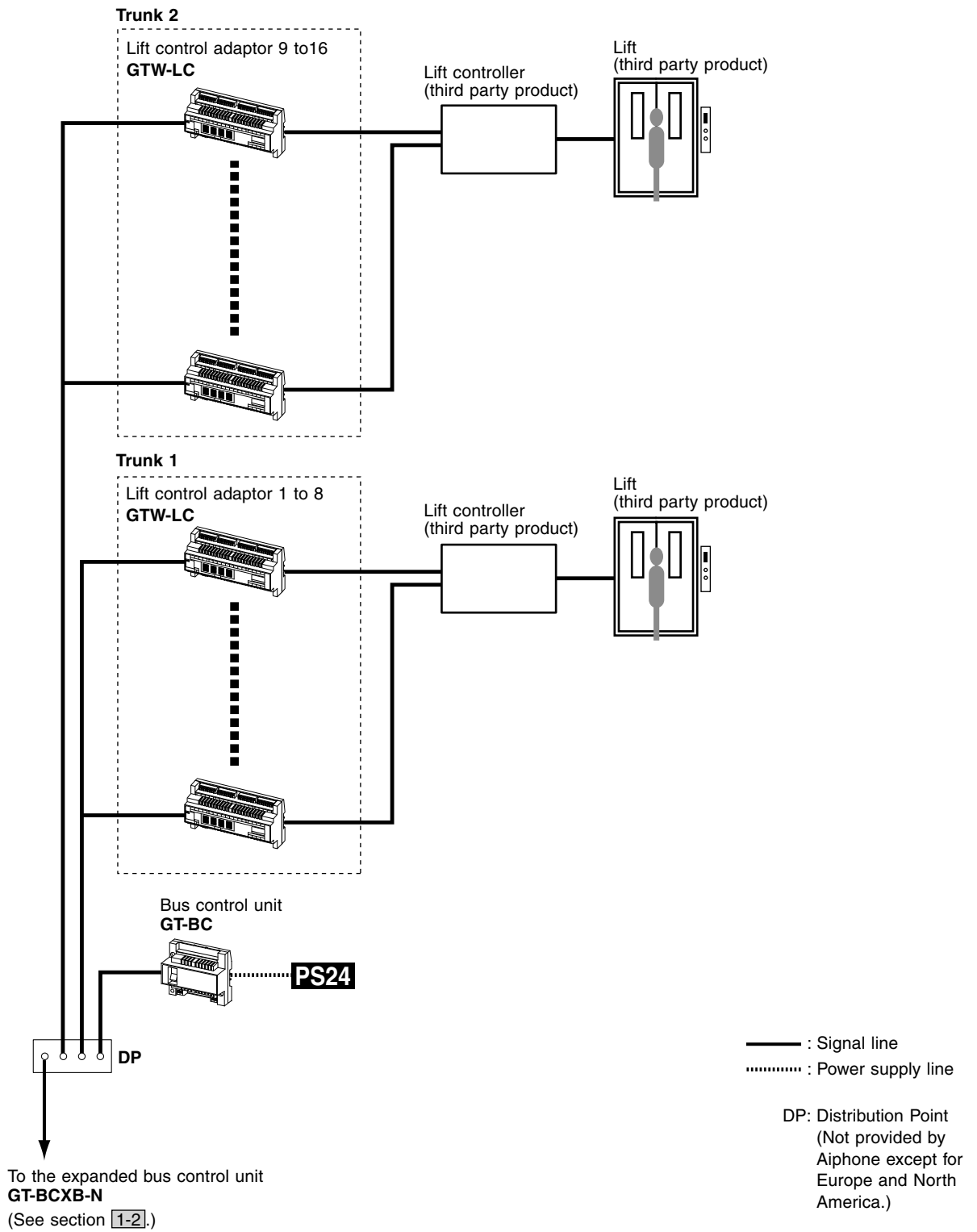

Device	Capacity
Lift control adaptor	Max. 16 (max. 8 per trunk)

1-5 Wiring distance

Standard system

[Station to peripheral devices]

Residence/tenant (GT-2C(-L) + GT-2H(-L) only)

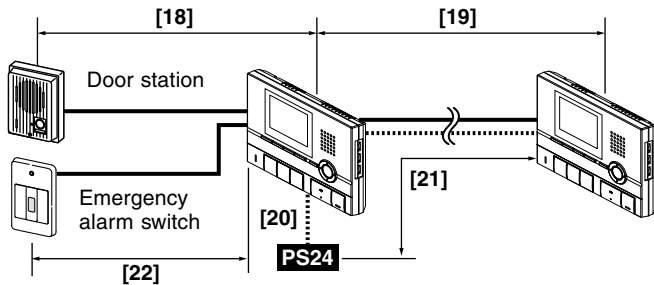

Residence/tenant (GT-1C7W(-L) only)

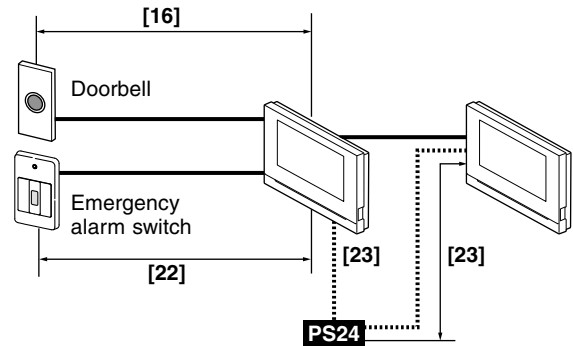

Residence/tenant (e.g. GT-1C7(-L))

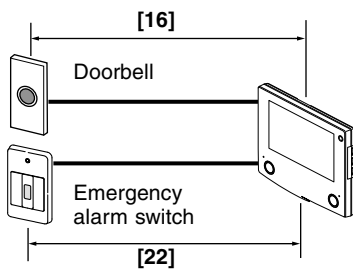

[GT-4Z to residential/tenant stations] (e.g. GT-1C7)

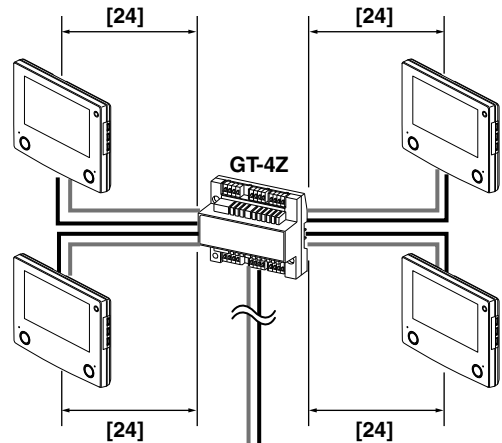

[GT-1Z to residential/tenant stations] (e.g. GT-1C7)

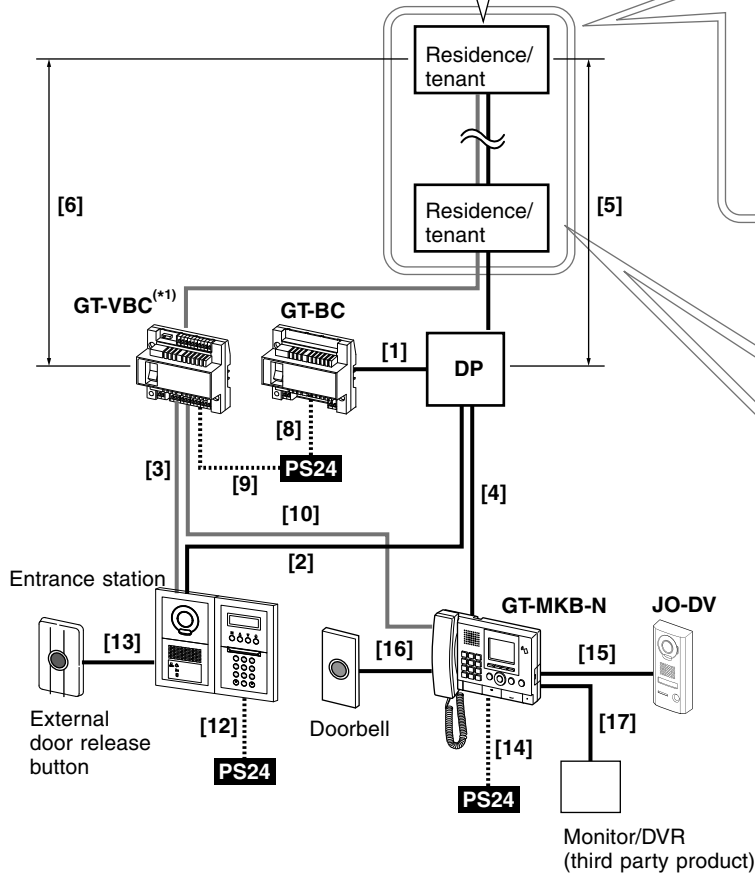
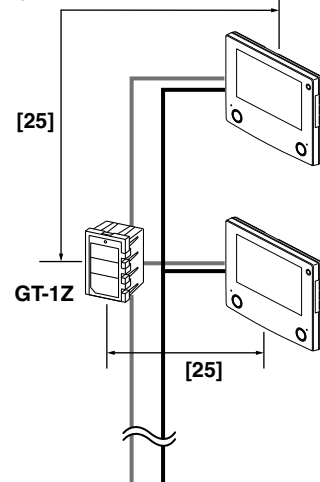

Expanded system

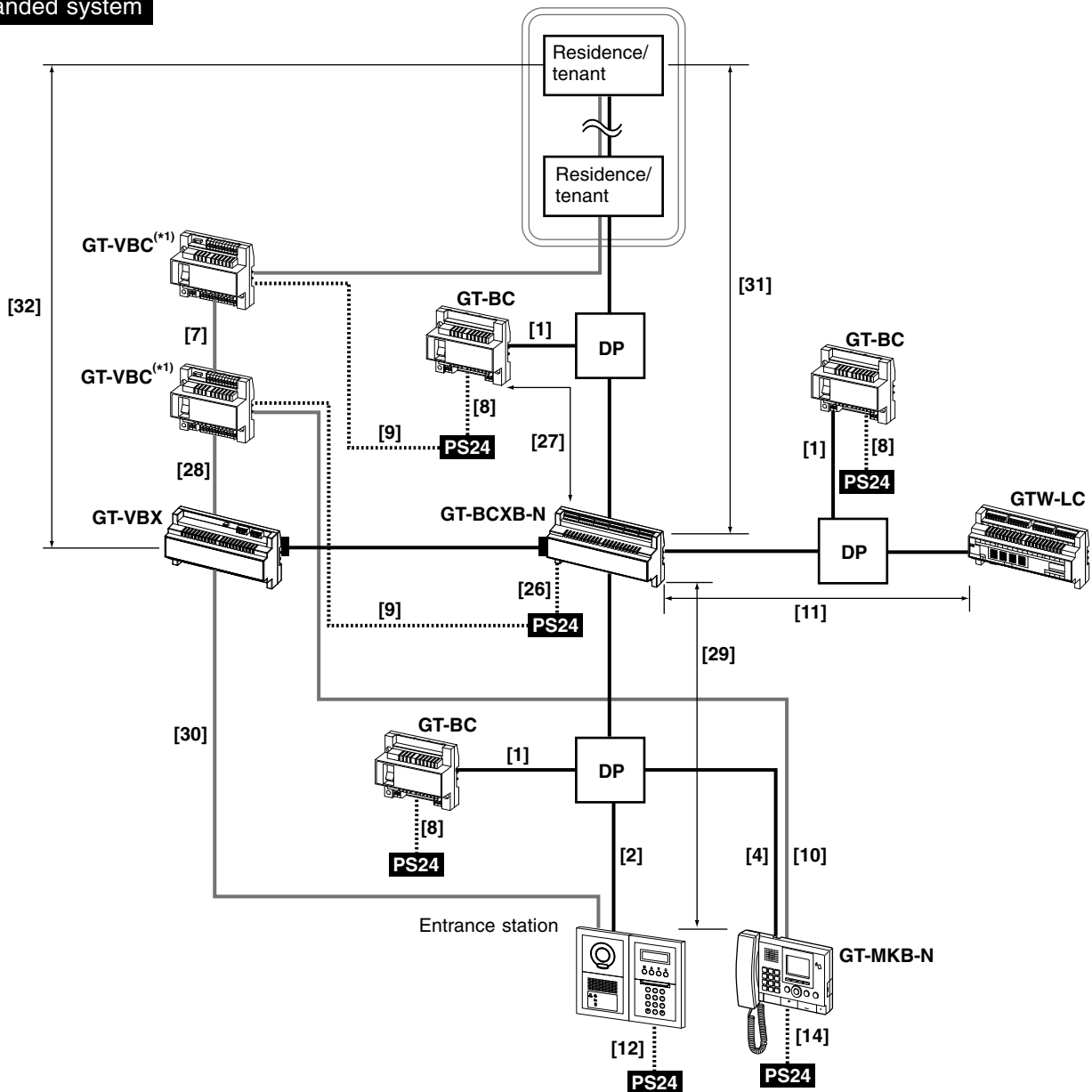

(*1): When using the GT-VBC as an extension adaptor

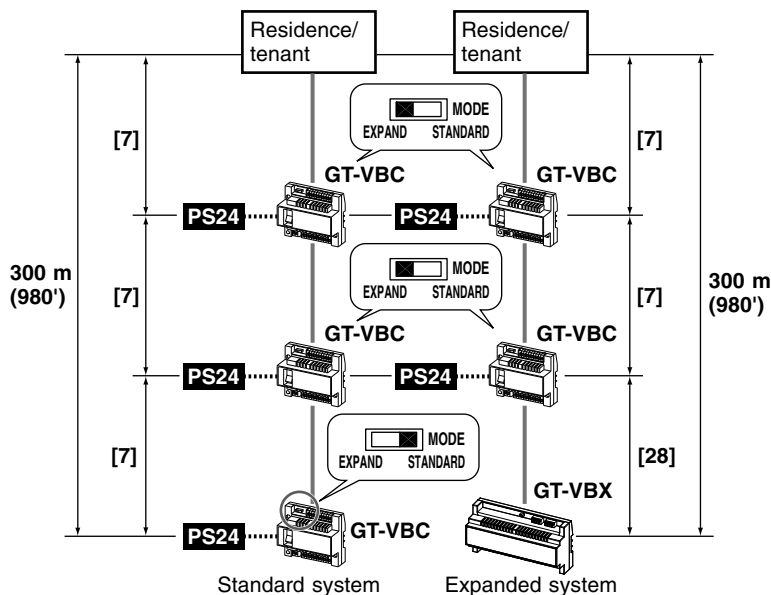

The GT-VBC can be used as an extension adaptor (2 units per sub trunk line). To do so, set the setting switch MODE to "EXPAND". Even if two units are used as extension adaptors (MODE: EXPAND), the wiring distance to the farthest residential/tenant station from the GT-VBC (MODE: STANDARD) or GT-VBX is limited to 300 m (980').

The table below shows the maximum wiring distances between devices.

Wiring distance		Wire diameter	0.65 mm (22 AWG)	0.8 mm (20 AWG)	1.0 mm (18 AWG)
[1]	GT-BC - DP *2		3 m (10')	5 m (16')	5 m (16')
[2]	Entrance station - DP *2		150 m (490')	300 m (980')	300 m (980')
[3]	Entrance station - GT-VBC		150 m (490')	300 m (980')	300 m (980')
[4]	GT-MKB-N - DP *2		150 m (490')	300 m (980')	300 m (980')
[5]	DP *2 - farthest residential/tenant station (includes system with GT-4Z or GT-1Z)		150 m (490')	300 m (980')	300 m (980')
[6]	GT-VBC - farthest residential/tenant station (includes system with GT-4Z or GT-1Z) *4		100 m (330')	150 m (490')	150 m (490')
[7]	GT-VBC (MODE: STD / EXP) - GT-VBC (MODE: EXP)		100 m (330')	150 m (490')	150 m (490')
[8]	GT-BC - power supply *3		3 m (10')	5 m (16')	5 m (16')
[9]	GT-VBC - power supply *3		3 m (10')	5 m (16')	5 m (16')
[10]	GT-VBC - farthest GT-MKB-N		100 m (330')	150 m (490')	150 m (490')
[11]	GT-BCXB-N - farthest GTW-LC		150 m (490')	300 m (980')	300 m (980')
[12]	Entrance station - power supply *3		150 m (490')	300 m (980')	300 m (980')
[13]	Entrance station - external door release button		10 m (33')	15 m (49')	15 m (49')
[14]	GT-MKB-N - power supply *3		100 m (330')	150 m (490')	150 m (490')
[15]	GT-MKB-N - JO-DV		30 m (100')	50 m (165')	50 m (165')
[16]	Residential/tenant station/GT-MKB-N - doorbell		5 m (16')	10 m (33')	10 m (33')
[17]	GT-MKB-N - monitor/DVR		Coaxial cable 15 m (49')		
[18]	Door station - GT-2C-L, GT-2C		50 m (165')	100 m (330')	100 m (330')
[19]	GT-2C-L, GT-2C - farthest GT-2H-L, GT-2H		50 m (165')	100 m (330')	100 m (330')
[20]	GT-2C-L, GT-2C - power supply		25 m (82')	50 m (165')	75 m (245')
[21]	GT-2H-L, GT-2H - power supply		50 m (165')	100 m (330')	150 m (490')
[22]	Residential/tenant station - emergency alarm switch		10 m (33')	15 m (49')	15 m (49')
[23]	GT-1C7W-L, GT-1C7W - power supply		25 m (82')	50 m (165')	75 m (245')
[24]	GT-4Z - residential/tenant station		30 m (100')	50 m (165')	50 m (165')
[25]	GT-1Z - residential/tenant station		10 m (33')	15 m (49')	15 m (49')
[26]	GT-BCXB-N - power supply *3		3 m (10')	5 m (16')	5 m (16')
[27]	GT-BCXB-N - GT-BC		150 m (490')	300 m (980')	300 m (980')
[28]	GT-VBX - GT-VBC (MODE: EXP)		100 m (330')	150 m (490')	150 m (490')
[29]	Entrance station, GT-MKB-N - GT-BCXB-N		150 m (490')	300 m (980')	300 m (980')
[30]	Entrance station - GT-VBX		150 m (490')	300 m (980')	300 m (980')
[31]	GT-BCXB-N - farthest residential/tenant station (includes system with GT-4Z or GT-1Z)		150 m (490')	300 m (980')	300 m (980')
[32]	GT-VBX - farthest residential/tenant station (includes system with GT-4Z or GT-1Z) *4		150 m (490')	300 m (980')	300 m (980')
	GT-DB-V, GT-DB-VN, GT-DMB-LVN - (VIGIK) *5		5 m (16')	10 m (33')	10 m (33')
	Standard system audio [R1, R2] total wiring distance *1		1650 m (5400')	2500 m (8200')	2500 m (8200')
	Expanded system audio [R1, R2] total wiring distance per common line (maximum 2 trunk lines)		1650 m (5400')	2500 m (8200')	2500 m (8200')
	Expanded system audio [R1, R2] total wiring distance per common line (maximum 4 trunk lines)		1650 m (5400')	2500 m (8200')	2500 m (8200')
	Lift control total wiring distance from GT-BCXB-N (including GTW-LC)		1650 m (5400')	2500 m (8200')	2500 m (8200')
	GT-RY - residential/tenant station		5 m (16')	10 m (33')	10 m (33')
	GT-2C-L, GT-2C - external monitor		1.5 m (5')	3 m (10')	3 m (10')
	Entrance station - surveillance camera		Coaxial cable 15 m (50')		

*1: The wiring distances from a door station to a GT-2C-L or GT-2C are not included in the total wiring distance.

*2: DP = Distribution Point (Not provided by Aiphone except for Europe and North America.)

*3: When powering two or more devices with one power supply, separate the cables near the power supply.







*4: The wiring distance between GT-VBX or GT-VBC (STANDARD) to the farthest residential/tenant station by using GT-VBC (EXPAND) is 300 m (980') regardless of the wiring method.

*5: A shielded wire is required.

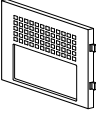
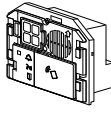

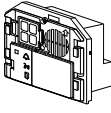
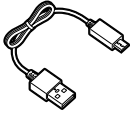
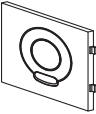
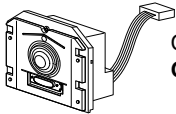
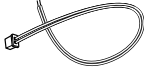
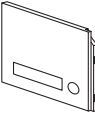
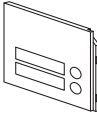
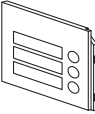
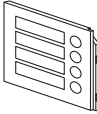
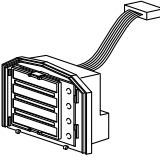
2 COMPONENTS

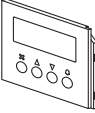
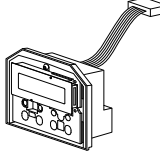
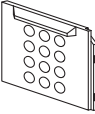
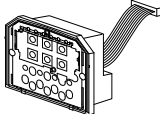
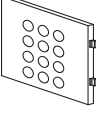
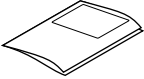
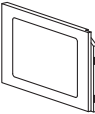
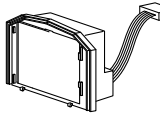
2-1 Entrance station (modular type)

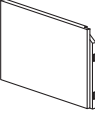
Panel	Module	
 <p>Audio panel GT-DBP</p>	 <p>Audio module GT-DB-VN (VIGIK and NFC capable)</p>	 <p>Option connector (7-pin)</p>
	 <p>Audio module • GT-DB-V (VIGIK capable) • GT-DB</p>	 <p>USB cable A-Micro B type (1 m)</p>
 <p>Camera module panel GT-VP</p>	 <p>Camera module GT-VB</p>	 <p>Option connector (2-pin)</p>
 <p>1-call button panel GF-1P</p>  <p>2-call button panel GF-2P</p>  <p>3-call button panel GF-3P</p>  <p>4-call button panel GF-4P</p>	 <p>Call switch module GT-SW</p>	 <p>Name card</p>
 <p>Name scrolling module panel GT-NSP-L</p>	 <p>Name scrolling module GT-NSB</p>	
 <p>10 key module panel GF-10KP</p>	 <p>10 key module GT-10K</p>	
 <p>Access control keypad module with panel GT-AC</p>	 <p>Installation & operation manual</p>	
 <p>Address module panel GF-AP</p>	 <p>Address module GT-AD</p>	 <p>Address card</p>  <p>Address cover</p>
 <p>Blank panel GF-BP</p>		

* All the above products except GT-DB-V include the Chinese RoHS paper.

Mounting parts

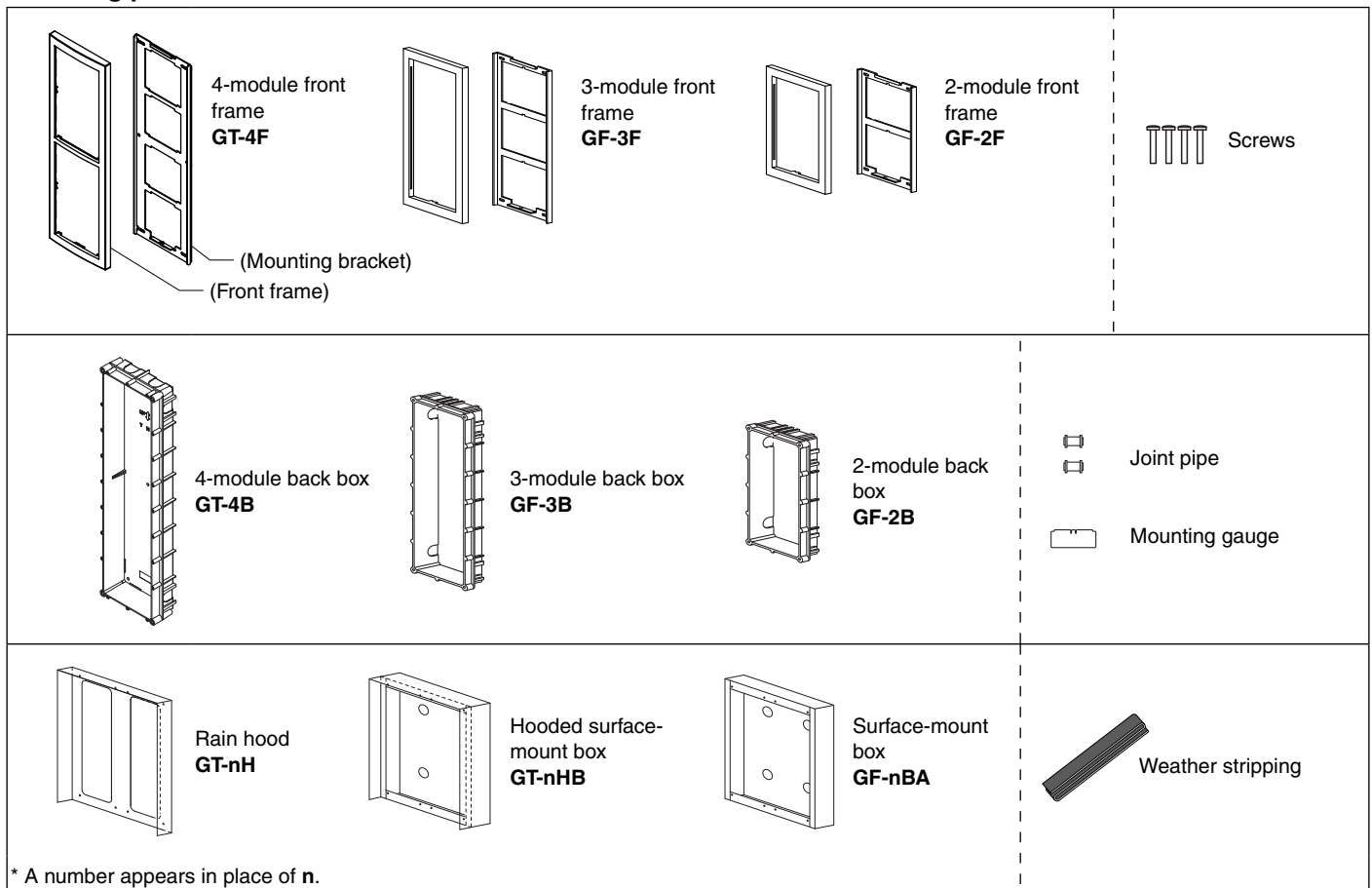

Combination examples

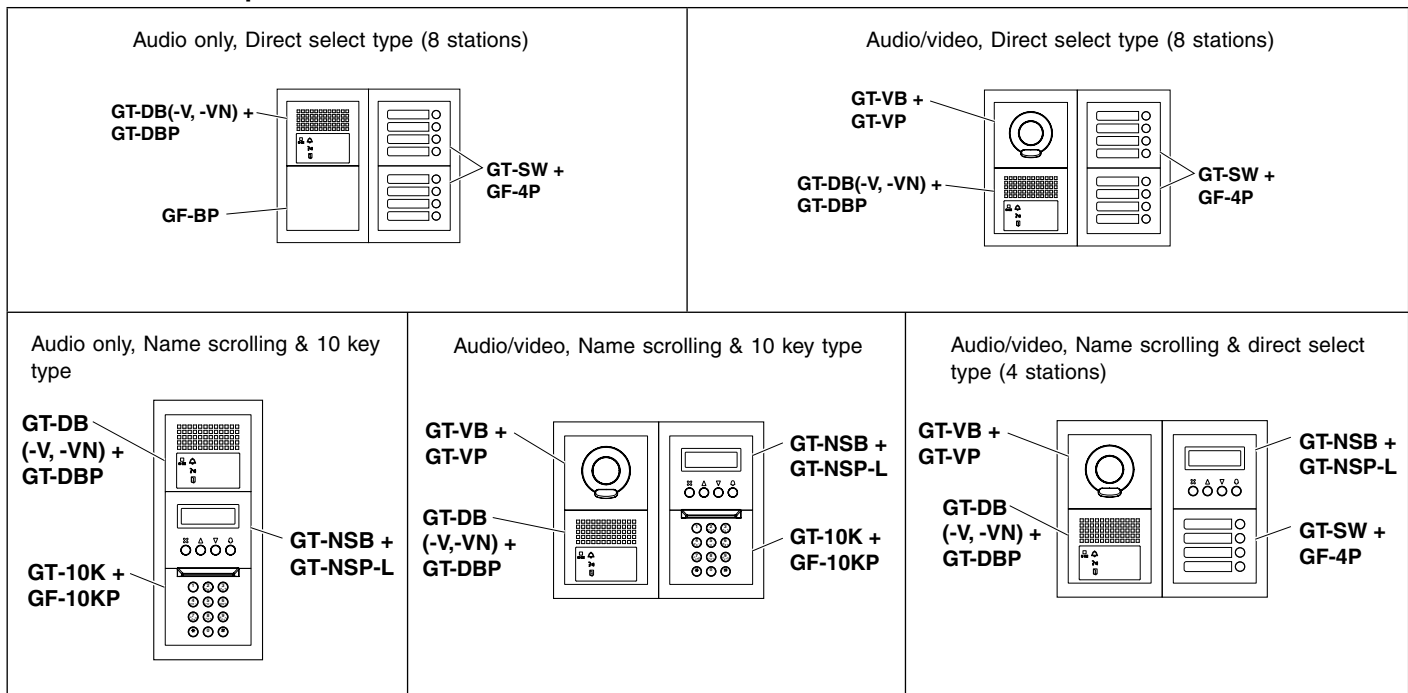

2-2 Entrance station (all-in-one type)

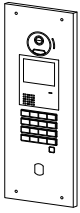

All-in-one entrance station
GT-DMB-LVN
(VIGIK and NFC capable)
* GT-4B back box sold separately.



All-in-one entrance station
GT-DMB-N
(NFC capable)
* GF-3B back box sold separately.



USB cable
A-Micro B type (1 m)



Option connector
(7-pin)



Special
screwdriver



Screws

* All the above products except GT-DMB-LVN include the Chinese RoHS paper.

2-3 Bus control unit etc.

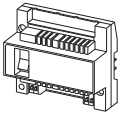

Bus control unit
GT-BC



Special
screwdriver

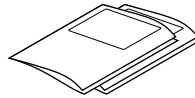

- English, French installation manual (this manual)
- English, French quick start guide
- Caution sheet (for user)

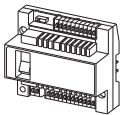

Video bus control unit
GT-VBC

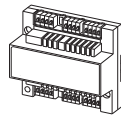

4-way video junction unit
GT-4Z

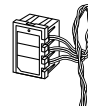

Video 1-zone divider
GT-1Z

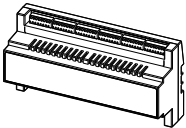

Expanded bus control unit
GT-BCXB-N
(NFC capable)



USB cable
A-Micro B type (1 m)

* A mounting bracket "DIN rail" included.

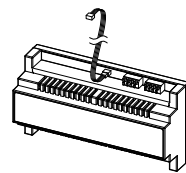

Expanded video bus control unit
GT-VBX

* A mounting bracket "DIN rail" included.

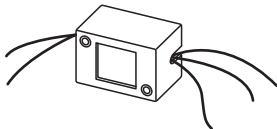











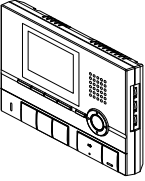



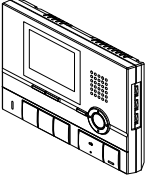

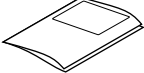
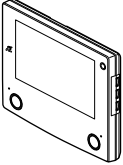
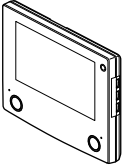
External
signaling relay
GT-RY

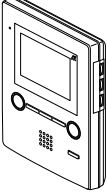

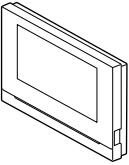
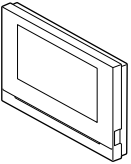
Wood mounting
screws

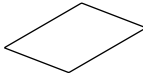
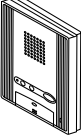
* All the above products include the Chinese RoHS paper.

2-4 Residential/tenant station, sub residential/tenant station

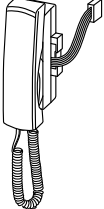
	<p>Residential/tenant station</p> <ul style="list-style-type: none"> • GT-2C-L (hearing aid-compatible) • GT-2C <p>* A mounting bracket is attached to the product.</p>	 Wood mounting screws  Screws  Option connector (12-pin) (included with GT-2C-L, GT-2C)
	<p>Sub residential/tenant station</p> <ul style="list-style-type: none"> • GT-2H-L (hearing aid-compatible) • GT-2H <p>* A mounting bracket is attached to the product.</p>	 Option connector (12-pin) (included with GT-2C-L, GT-2C)  Operation manual
	 <p>Residential/tenant station</p> <p>GT-1C7</p> <p>* A mounting bracket is attached to the product.</p>	 Option connector (6-pin)
	 <p>Residential/tenant station</p> <p>GT-1M3</p> <p>* A mounting bracket is attached to the product.</p>	
	 <p>Residential/tenant station</p> <p>GT-1C7W</p> <p>* A mounting bracket is attached to the product.</p>	 Option connector (4-pin)  Information sheet
	<p>Residential/tenant station</p> <p>GT-1A</p> <p>* A mounting bracket is attached to the product.</p>	 Wood mounting screws  Screws
	<p>Residential/tenant station</p> <p>GT-1D</p>	 Option connector <ul style="list-style-type: none"> • GT-1A: 6-pin • GT-1D: 8-pin
	<p>Optional handset for GT-2C(-L), GT-2H(-L)</p> <p>GT-HSA</p>	

* All the above products include the Chinese RoHS paper.

2-5 Door station

* For JK-DA, refer to the instruction manual included with the product for details.

[For GT-2C-L, GT-2C]

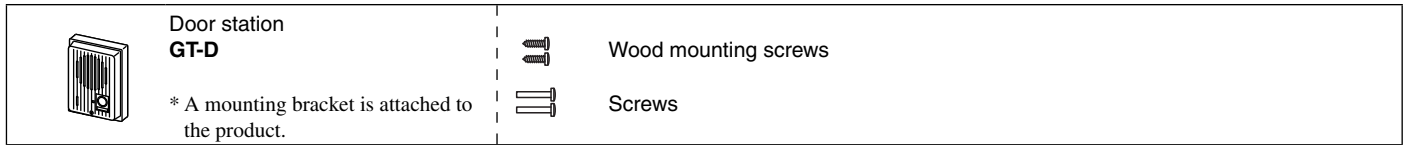

[For GT-MKB-N]

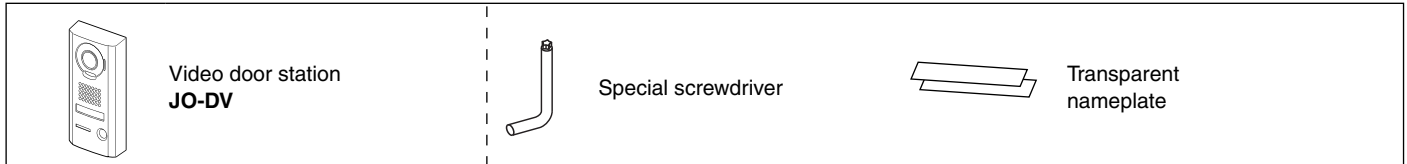

2-6 Guard station

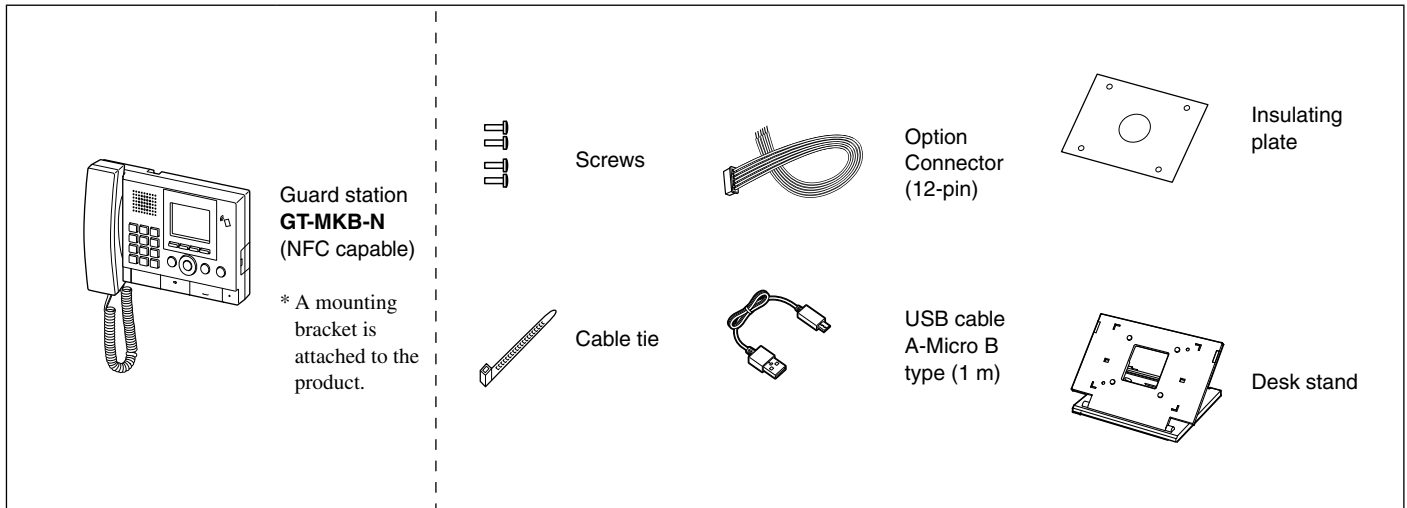

2-7 Lift control adaptor

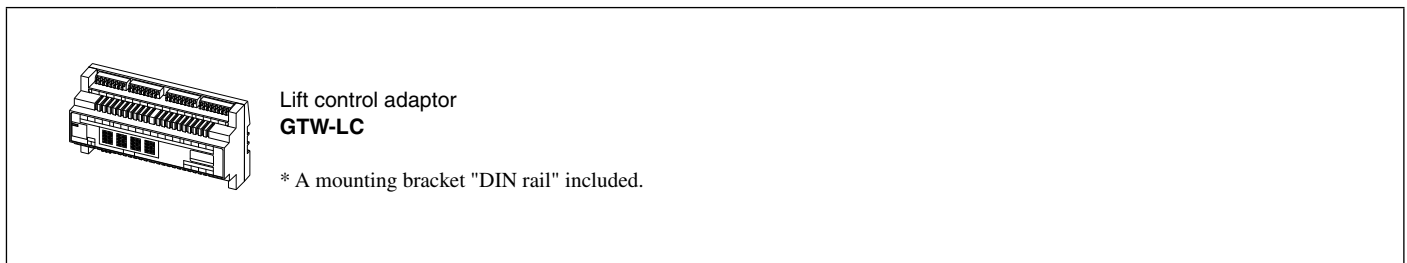

* All the above products include the Chinese RoHS paper.

3 MOUNTING

3-1 Mounting locations

For video entrance stations and video door stations, the picture quality of the residential/tenant station monitor is affected by the external light surrounding the built-in camera. Do not install these stations in the types of locations shown below.

- Locations exposed to direct sunlight
- Locations under street lights or door lights
- Other locations exposed to strong light

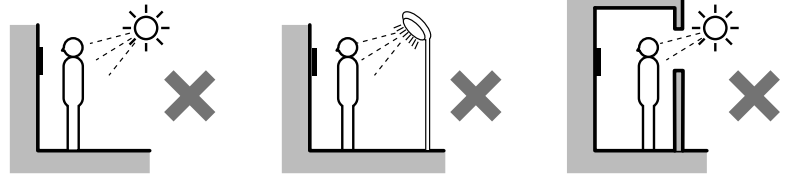

Entrance stations (all-in-one type) include a sensor. Do not place objects such as plants or trees in places monitored by the sensor. Also, placing the unit in bright sunlit areas may prevent the sensor from working properly.

Residential/tenant station, sub residential/tenant station

- Do not install the station at a location exposed to direct sunlight.
- Avoid installing the station in a concave space of a wall to prevent audio distortion.
- Do not embed the station inside a wall.

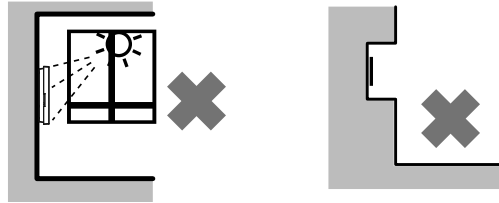

GT-2C-L/GT-2C, GT-2H-L/GT-2H, GT-1C7-L/GT-1C7, GT-1M3-L/GT-1M3

- Controls are located on the right side of the station. Allow open space of 5 cm (2").
- At least 15 cm (6") of vertical open space from the center of the mounting bracket is needed for mounting the station.

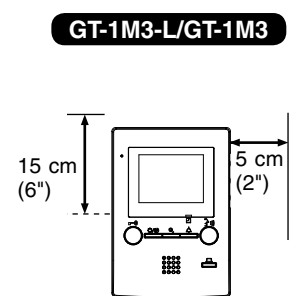
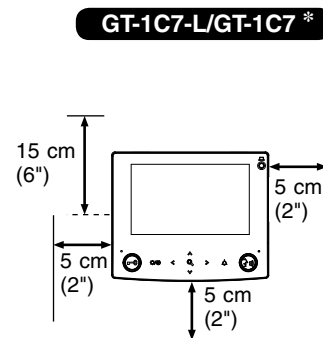
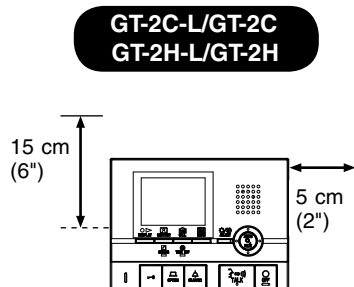
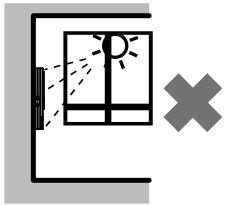

* GT-1C7-L/GT-1C7 only

The station's speaker is on the back. Make sure to leave the specified spaces on all sides to ensure sound clarity.

GT-1C7W-L/GT-1C7W

- Make sure to leave at least the specified spaces on all sides to prevent malfunction and audio distortion.

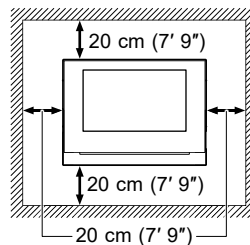

- The reset button is on the left side and the microSDHC card slot is on the right side of the station. Be sure to install the station at a location where all buttons can be reached by hand.
- Install the station more than 3 meters apart from all wireless equipment.

3-2 Wi-Fi installation requirements **GT-1C7W-L/GT-1C7W only**

The residential/tenant station incorporates wireless LAN antennas. The Wi-Fi signal may not reach the station depending on the installation environment such as wall materials or the number of walls. Make sure the station receives a Wi-Fi signal successfully before installing the station. If the Wi-Fi signal does not reach the station, change the installation location of the router or the station.

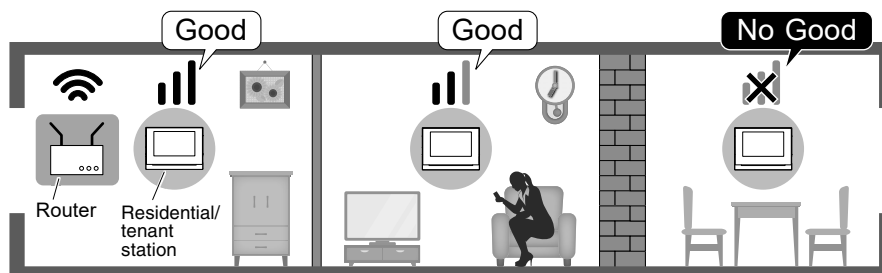

- Partition masonry walls
- Wood walls
- Plasterboard walls

- Reinforced concrete walls
- Load-bearing walls
- Stone walls
- Metal walls

3-3 Cable

- Use PE (polyethylene)-insulated PVC jacket cable.
- Parallel or jacketed 2-conductor, mid-capacitance non-shielded cable is recommended.
- Never use individual conductors, twisted pair cable or coaxial cable.

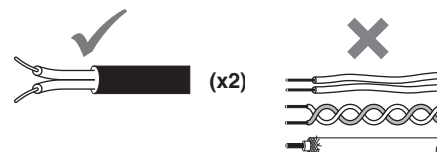

To connect low voltage wires, either crimp them with a crimp sleeve or solder them, and then insulate by covering with insulating tape.

[Crimping with a crimp sleeve]

1. Line up solid and stranded conductors, and crimp them.

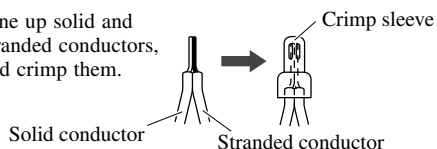

2. Overlap more than half of the width and twist them at least twice.

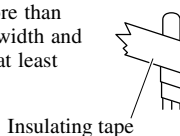

[Soldering]

1. Twist the stranded conductor around the solid conductor at least three times.

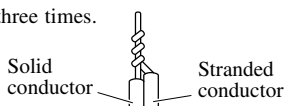

2. Bend the tip and solder it. Make sure no lead wire sticks out.

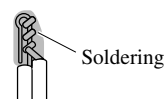

3. Overlap more than half of the width and twist them at least twice.

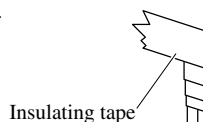

! Keep the number of connections as low as possible when wiring.

After connecting wires, make sure to check for breaking or insufficient connection. Especially when connecting a wire in the middle of wiring, either crimp it with a crimp sleeve or solder it, and then insulate it by covering with an insulating tape.

Just twisting wires may cause poor connection, or the surface of the wires may get oxidized to cause a loose connection, leading to malfunctioning or failure.



NOTES:

- If the lead wire with a connector is short, extend it using an interconnecting cable.
- Connectors have polarity, so pay attention and connect properly. If connected incorrectly, the device won't work.

3-4 Mounting positions and image view area

⚠ When using the camera module, if the rain hood is attached a portion of it will show up in the camera display.

NOTE: Follow the applicable laws and regulations for mounting location.

Wide view

Vertical

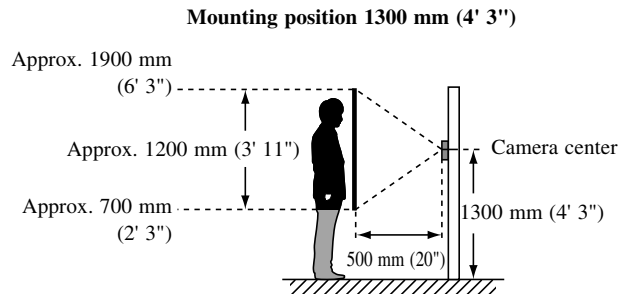
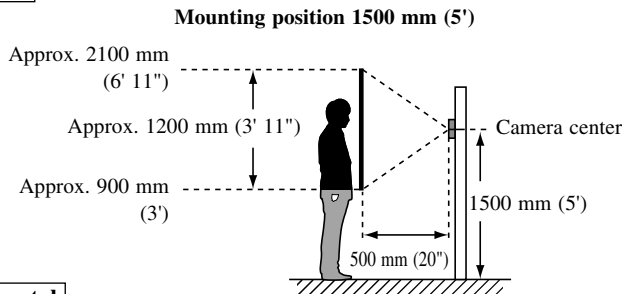

Horizontal

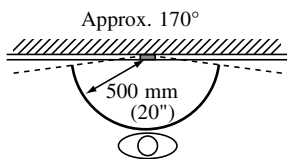

An area over a range of approx. 170° in a 500 mm (20") radius from the camera displays. (The display range is a rough estimation and may change due to the installation environment.)

Zoom view

Vertical (with mounting position of 1500 mm (5'))

<Up>

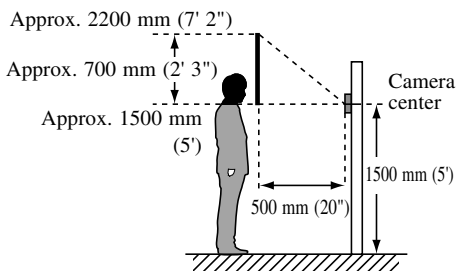

<Center>

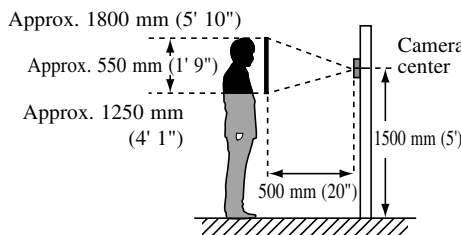

<Down>

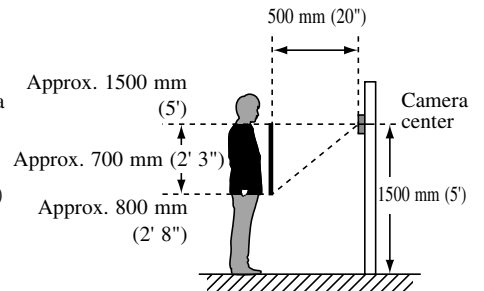

Horizontal

<Left>

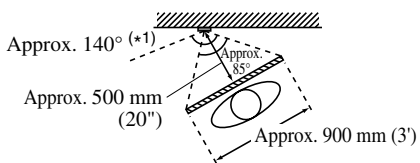

<Center>

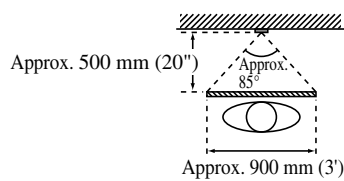

<Right>

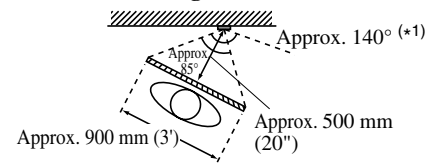

(*1): Zoom view range is approx. 140° at 500mm (20") distance from the camera.

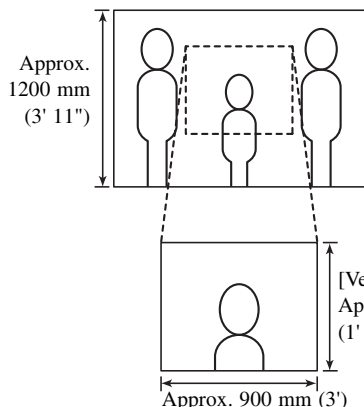

Objects appear smaller due to greater distortion in the surrounding sections compared to the central section, but a wider area is displayed. The display range is a rough estimation and may change due to the installation environment.

The zoom position can be changed. The default zoom position is center.

3-5 Entrance station (modular type)

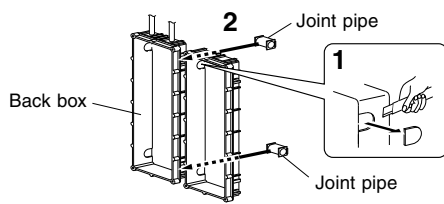

- 1 Make a hole for the cable.
- 2 Use the joint pipe to assemble the back box.
 - Make sure the back box is mounted level.

Back box assembly dimensions

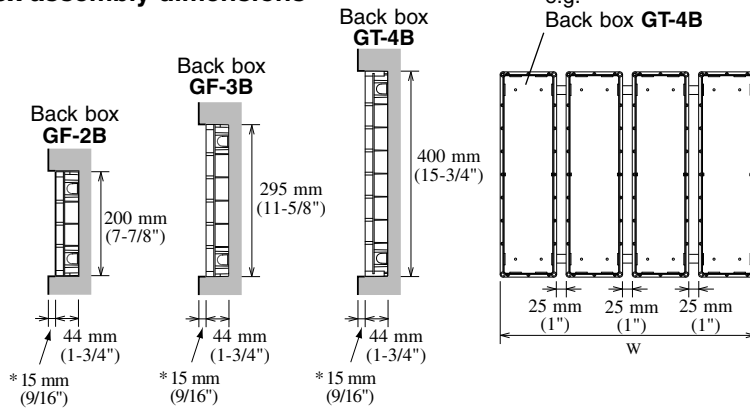

GF-2B, GF-3B, GT-4B		
QTY.	W (mm)	W (inch)
x 1	110	4-5/16"
x 2	245	9-5/8"
x 3	380	14-15/16"
x 4	515	20-1/4"

* Do not mount the back box on a surface that is recessed by 15 mm (9/16") or more from the external surface of the wall.

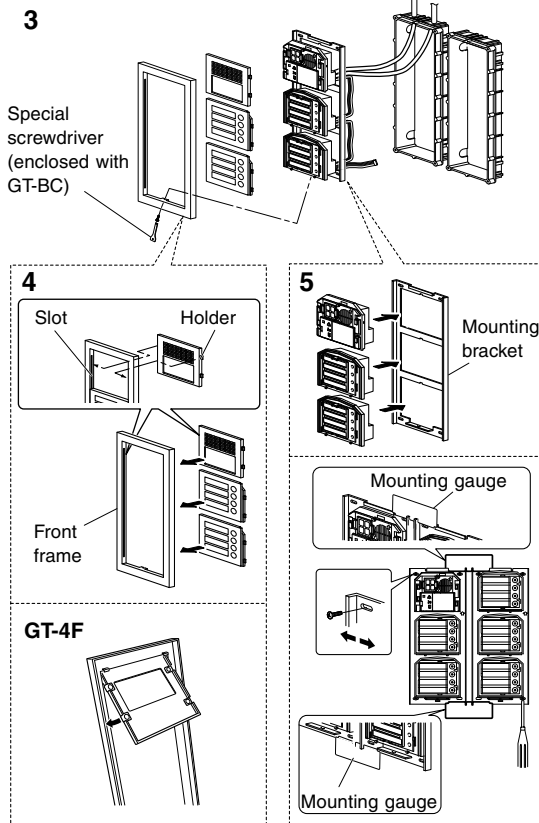

- 3 Assemble the modules.
 - For the useable modules, see section 2-1.
 - The GT-SW can have up to 6 modules.

To connect 7 or more modules or to increase the light intensity, please contact supplier (need other parts).

NOTE: Before mounting modules to the front panel, complete wiring and DIP switch settings. (Refer to chapter 4 "Wiring" and chapter 5 "Settings".)

- 4 Mount each module panel to the front frame.
 - Mount the panels from behind the front frame.
 - Insert the holders into the slots on both sides. (With the GT-4F, mount the module panels so that they catch on the tabs from top to bottom.)
- 5 Mount each module, except the GT-AC, to the mounting bracket.
 - Set the modules in the mounting bracket until they click in place.
 - To mount multiple rows of modules, apply the mounting gauge to the mounting bracket. While using the mounting gauge to make adjustments, tighten the screws. (A mounting gauge is included with the GF-2B, GF-3B, and GT-4B built-in back boxes.)

Options

Rain hood GT-203H

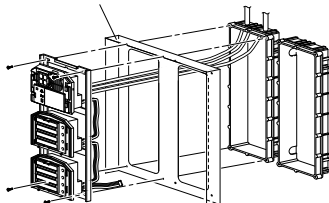

Hooded surface-mount box GT-203HB

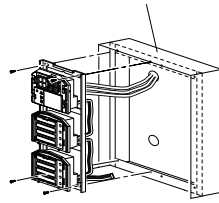

Surface-mount box GF-203BA

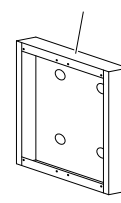

6 GT-DB/GT-DB-V/GT-DB-VN

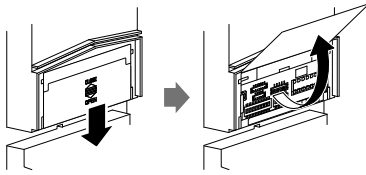

6 Slide down and then open the terminal cover, and connect wires to the terminal block. Insert the wire into the direct terminal. Press the tab to easily insert the wire into the terminal, then release.

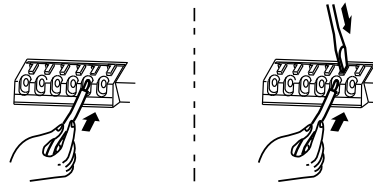

7

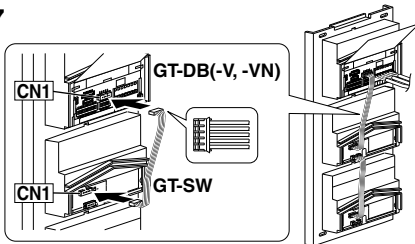

7 From the audio module to the next module, insert the attached connector into the socket.

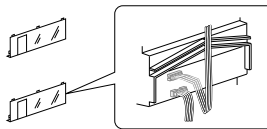

Make sure to run the cable under the terminal cover for protection.

8

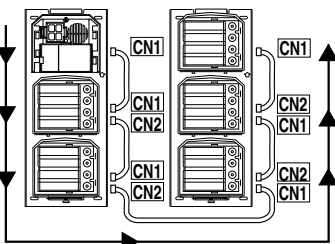

8 Attach the connection cables between the modules. Mount modules on the back boxes.

9

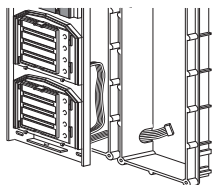

9 Run the connection cable through the joint pipe and connect CN1 of the GT-SW to the next row.

10

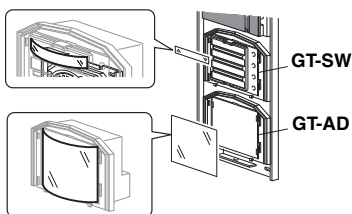

10 For the GT-SW and GT-AD, remove the resident name/address plate or paper by pressing either the left or right end. (Peel off the plastic film.) Use a permanent pen to write the resident name and address on the transparent plate and mount the plate on the module.

11 GT-DB/GT-DB-V/GT-DB-VN

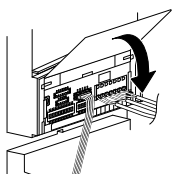

11 Close the terminal cover. Mount the front frame and tighten with the special screwdriver (included with GT-BC).

3-6 Entrance station (all-in-one type)

GT-DMB-LVN/GT-DMB-N

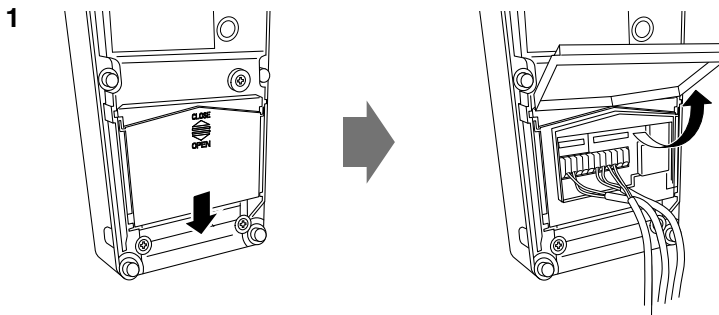

- 1** Slide down and then open the cover, and connect wires to the terminal block.

Insert the wire into the direct terminal. Press the tab to easily insert the wire into the terminal, then release.

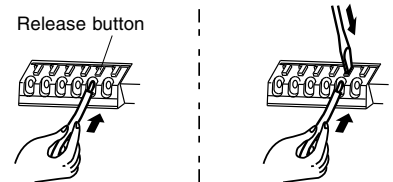

- 2** Close the cover until it clicks into place.

GT-DMB-LVN

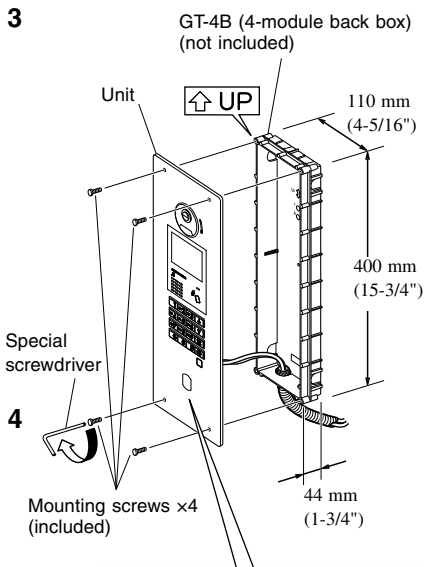

GT-DMB-N

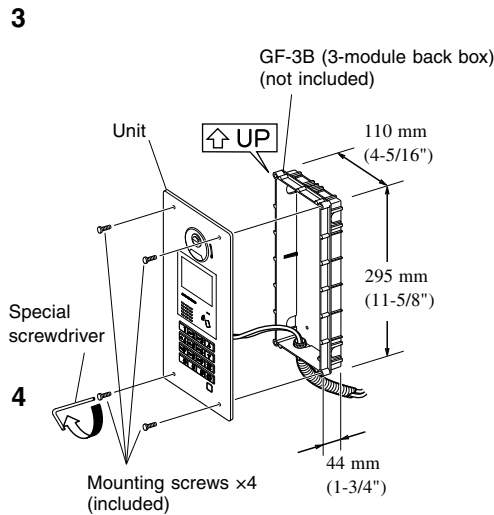

- 3** Mount the unit in the flush mount back box.

- 4** Tighten the locking screws using the special screwdriver.

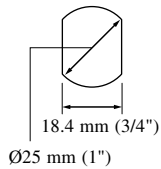

NOTE (GT-DMB-LVN only):
For installing VIGIK or a key cylinder, refer to the instructions included with the product.

3-7

Bus control unit, 4-way video junction unit, lift control adaptor and power supply

DIN rail mounting

⚠ The maximum cable length between the GT-BCXB-N and GT-VBX is 40 cm. Therefore, mount them side by side.

1 Mount the unit on the DIN rail and then click the unit into place, or mount the unit directly to a wall.

- GT-BC, GT-VBC, and GT-4Z do not include the DIN rail. Use the W-DIN11 for mounting these units.
- GT-BCXB-N, GT-VBX, GT-MCX and GTW-LC are mounted to the included DIN rail.

2 When removing the unit, pull the lock release lever down.

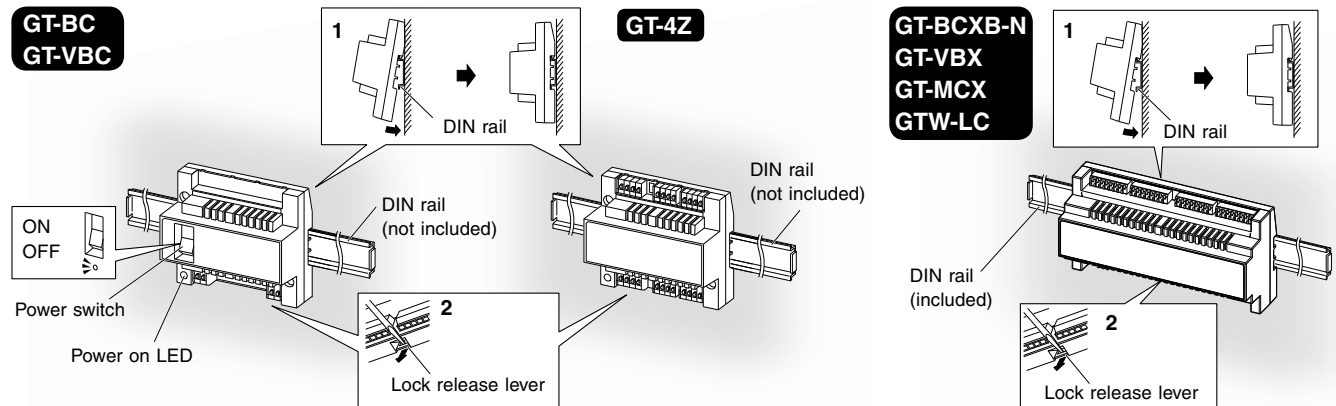

NOTES:

- Keep wiring away from NFC mark, as it may disturb the audio or video signals.
- Be sure to mount the other devices more than 20 cm (7-7/8") away from NFC mark of GT-BCXB-N.

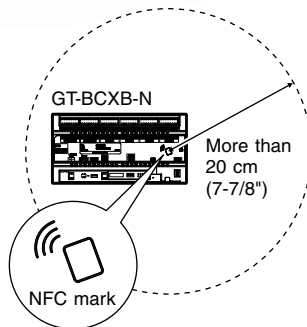

- Expanded video bus control unit GT-VBX

⚠ Connector cable length: 40 cm

Surface mounting

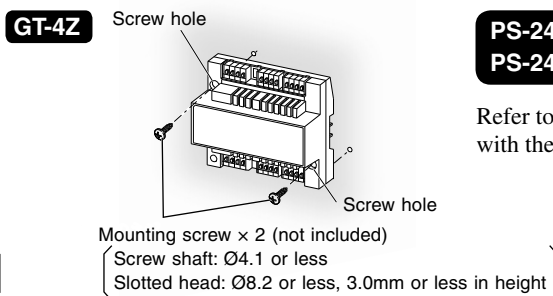
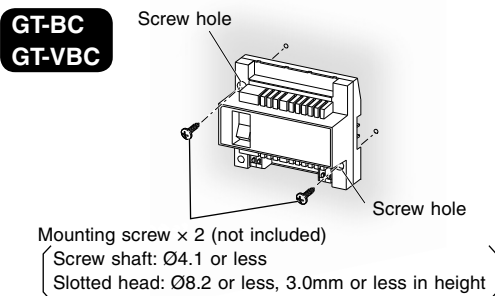

**PS-2420DM, PS-2420, PS-2420S
PS-2420UL, PS-2420BF**

Refer to the installation manual included with the product.

Wiring

Insert the wire into the terminal. Press the tab to easily insert the wire into the terminal, then release.

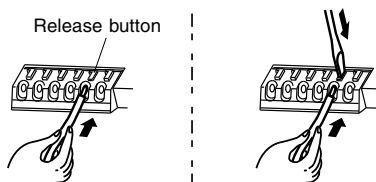

* The image of the terminals may differ from the actual product.

NOTE : When wood mounting screws cannot be used for plasterboard walls, concrete walls and so on, use commercially-available board anchors or concrete plugs.

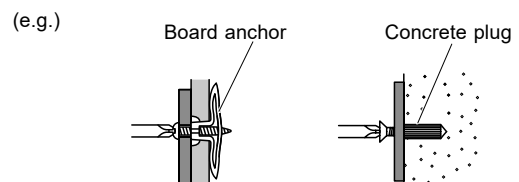

3-8 Residential/tenant station

NOTES

- When wood mounting screws cannot be used for plasterboard walls, concrete walls and so on, use commercially-available board anchors or concrete plugs.

(e.g.)

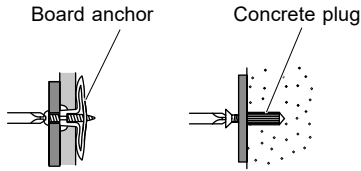

GT-2C-L/GT-2C
GT-2H-L/GT-2H

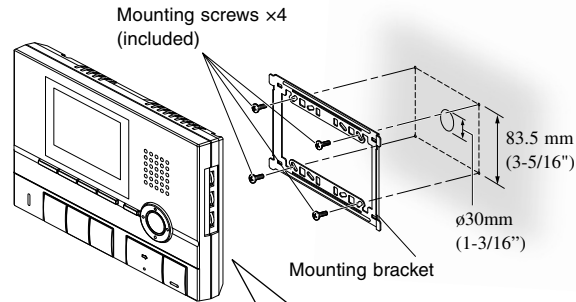

* When using a gang box, a 3-gang box is recommended.

- Press the release button (to insert or remove the wire).
- Insert the cable into the terminal.
 - To remove the terminal block, slide the terminal block and pull it out.
 - Strip away the jacket of the cable and insert all wires into the slots in an orderly fashion. Failure to do so could result in pinching that may damage the wiring.

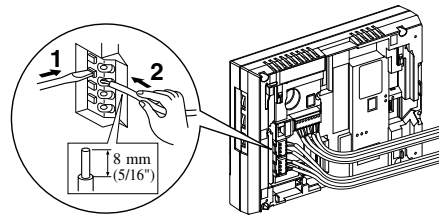

Surface wiring

- The cable can be routed as surface wiring to the top or bottom of the unit.

Cut a cable inlet on the upper part of the unit to allow passage of the wiring into the unit from above.

If there is a large amount of wiring, strip away the jacket of the cable up to the cable inlet.

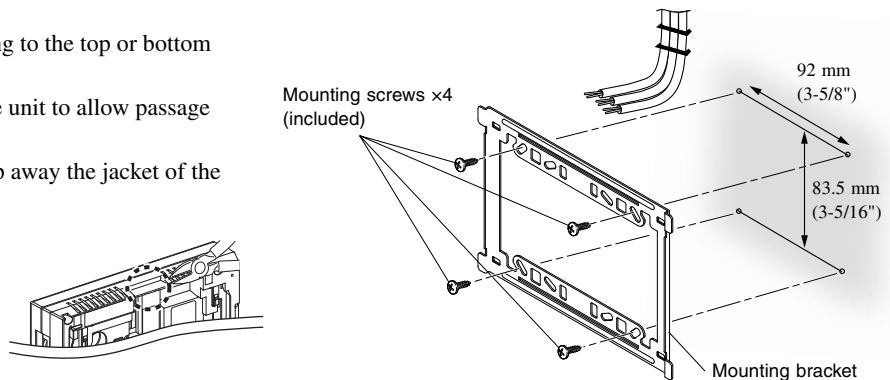

Optional handset

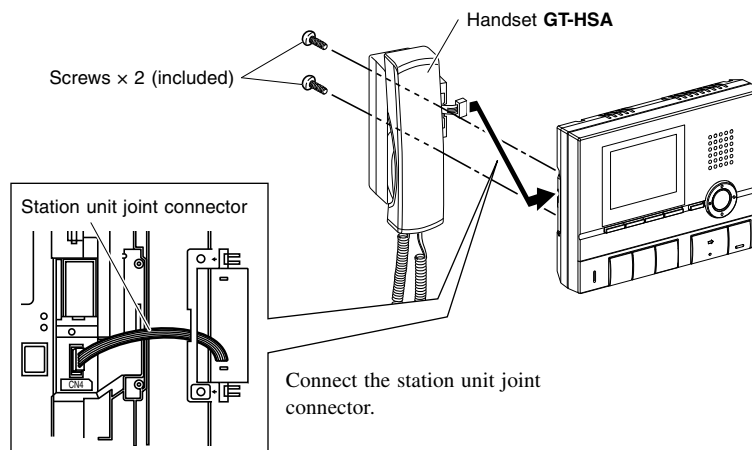

GT-1C7-L/GT-1C7, GT-1M3-L/GT-1M3

Back wiring

Cut a small round hole ($\varnothing 30\text{mm}$ (1-3/16")) in the wall for routing wires.

GT-1C7-L/GT-1C7

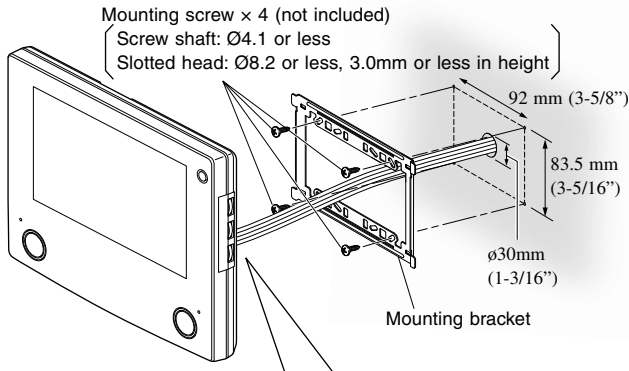

1. Press the release button (to insert or remove the wire).
2. Insert the wire into the terminal.

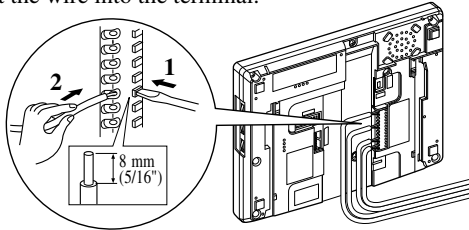

GT-1M3-L/GT-1M3

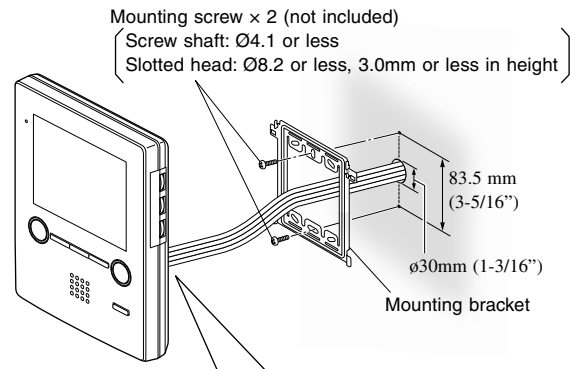

1. Press the release button (to insert or remove the wire).
2. Insert the wire into the terminal.

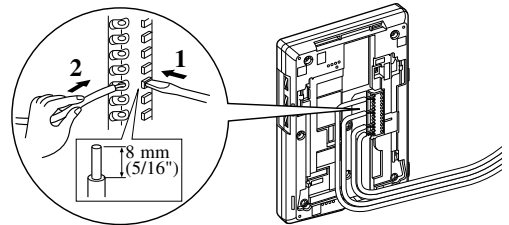

NOTES (GT-1C7-L/GT-1C7 only):

- The station has a speaker on the back. When using a gang box for routing the wires, use a single gang box and attach the mounting bracket to the wall as shown above. If a 2- or 3-gang box is used, audio quality may be altered.
- Depending on the material of the wall, volume and quality of sound coming from the speaker may be altered.

Surface wiring

The wires can be routed to the top or bottom of the station.

Cut the cable inlet to allow passage of the wiring into the station from above.

If there is a large amount of wiring, strip away the jacket of the wire up to the cable inlet.

GT-1C7-L/GT-1C7

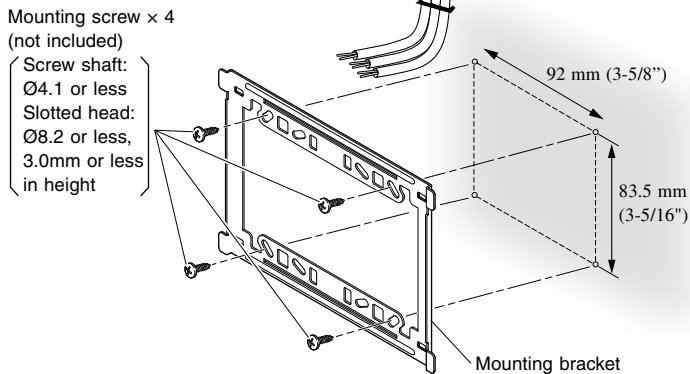

- * To pass the wire through the back of the station, cut out the cable inlet.

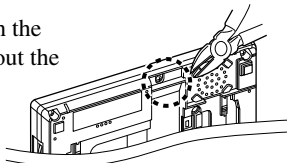

GT-1M3-L/GT-1M3

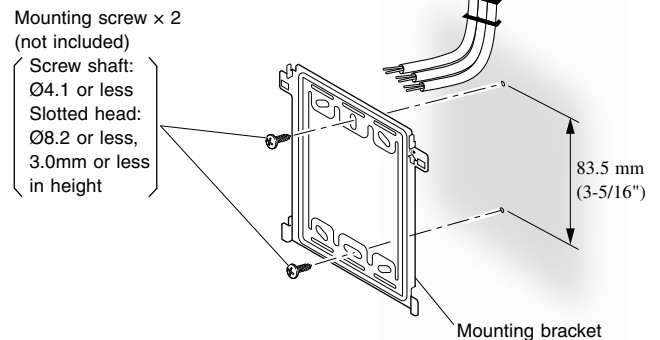

- * To pass the wire through the back of the station, cut out the cable inlet.

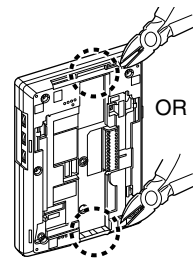

GT-1C7W-L/GT-1C7W

Back wiring

Cut a small round hole ($\varnothing 50\text{mm}$ (1-15/16")) in the wall for routing wires.

* Cut a hole at a position shifted 25 mm (1") to the right from the station center.

Wood mounting screw $\times 4$ (not included)

(Screw shaft: $\varnothing 4.1$ or less
Slotted head: $\varnothing 8.2$ or less,
3.0mm or less in height)

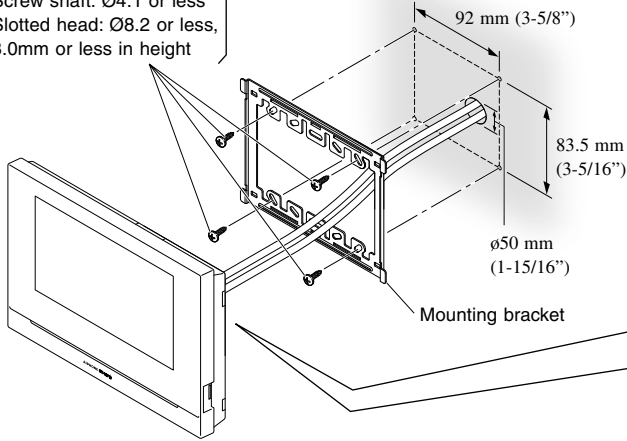

1. Press the release button (to insert or remove the wire).
2. Insert the wire into the terminal.

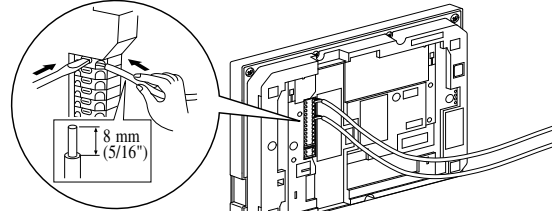

NOTE: When using a gang box, select a 3-gang box.

Surface wiring

The wires can be routed to the top or bottom of the station.

Cut the cable inlet to allow passage of the wiring into the station from the top or bottom of the station.

If there is a large amount of wiring, strip away the jacket of the wire up to the cable inlet.

Wood mounting screw $\times 4$
(not included)

(Screw shaft: $\varnothing 4.1$ or less
Slotted head: $\varnothing 8.2$ or less,
3.0mm or less
in height)

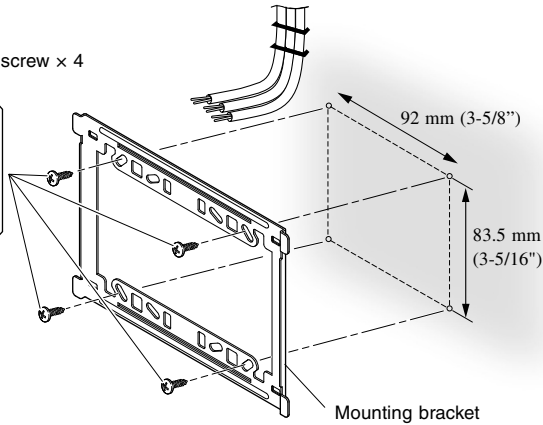

* To pass the wire through the back of the station, cut out the cable inlet.

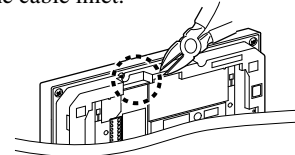

GT-1A

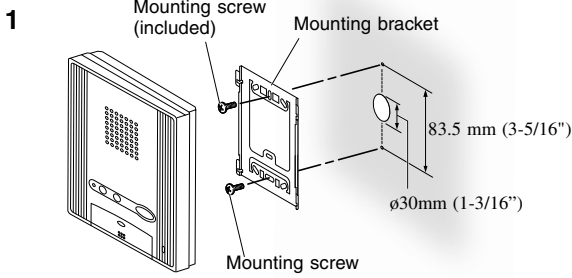

- 1** Mount the mounting bracket on the wall.
 * When using a gang box, a single gang box is recommended.

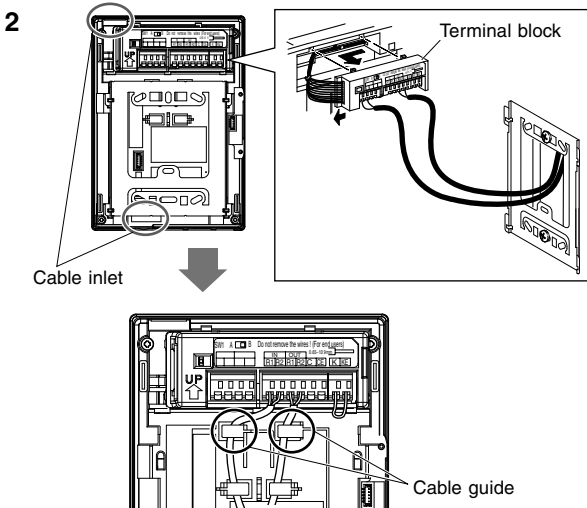

- 2** Connect wires to the terminal block.
 * If it is difficult to insert the wire, insert it while pressing the release button.

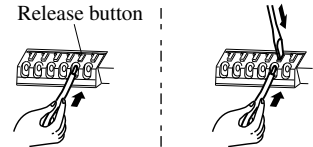

- To remove the terminal block, slide the terminal block and pull it out.
- Strip away the jacket of the wire and insert all wires into the slots in an orderly fashion. Failure to do so could result in pinching that may damage the wiring.
- For surface wiring, cut out the cable inlet.

NOTE: Be sure to route the wires inside the cable guides. Otherwise, the wires could be damaged when attaching the station to the mounting bracket.

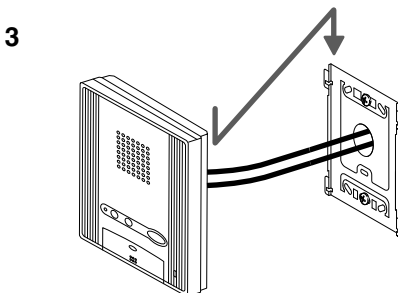

- 3** Mount the station to the mounting bracket.

GT-1D

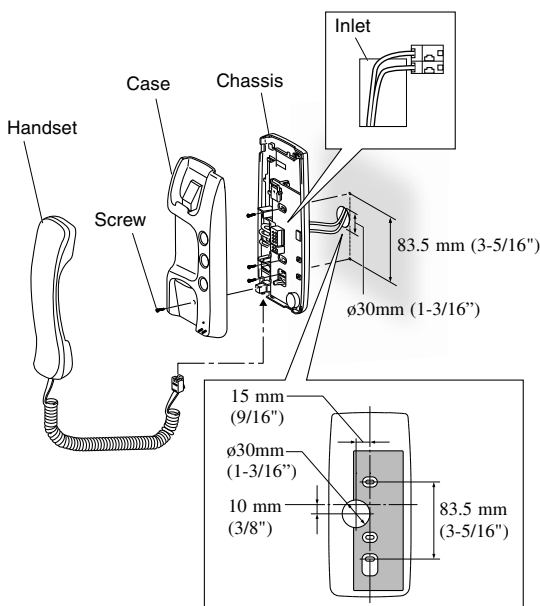

- ⚠** Be careful not to damage the circuit board when connecting wires and mounting the station. Failure to do so could damage the station.

NOTE : The surface wiring method cannot be used.

- 1** Remove the screw, and then remove the case from the chassis.
2 Route the wires through the wire inlet of the chassis, and then connect the wires.

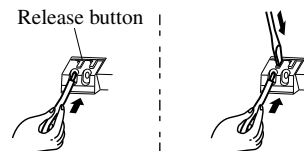

- ⚠** Turn off the GT-BC control unit before connecting wires. Failure to do so could damage the station.

- 3** Attach the chassis on the wall.
 * Be careful not to pinch the wires between the chassis and the wall.
 * When using a gang box, a single gang box is recommended.
4 Attach the case to the chassis and tighten the screw.
5 Plug in the handset to the jack.

* The image of the terminals may differ from the actual product.

3-9 Door station (for residential/tenant station)

GT-D

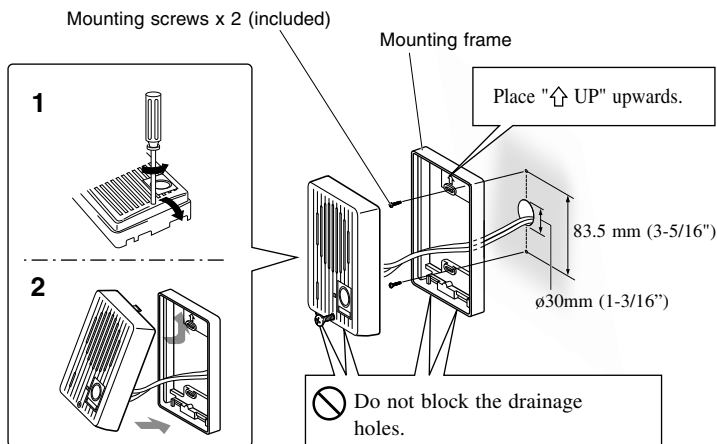

- 1** Loosen the screws and remove the mounting frame from the main unit.
- 2** Mount the mounting frame on the wall.
 - * When using a gang box, a single gang box is recommended.
- 3** After connecting the wiring, mount the main unit to the mounting frame.
 - For surface wiring, insert wiring from the cable inlet (lower part).

JO-DV (for GT-MKB-N only)

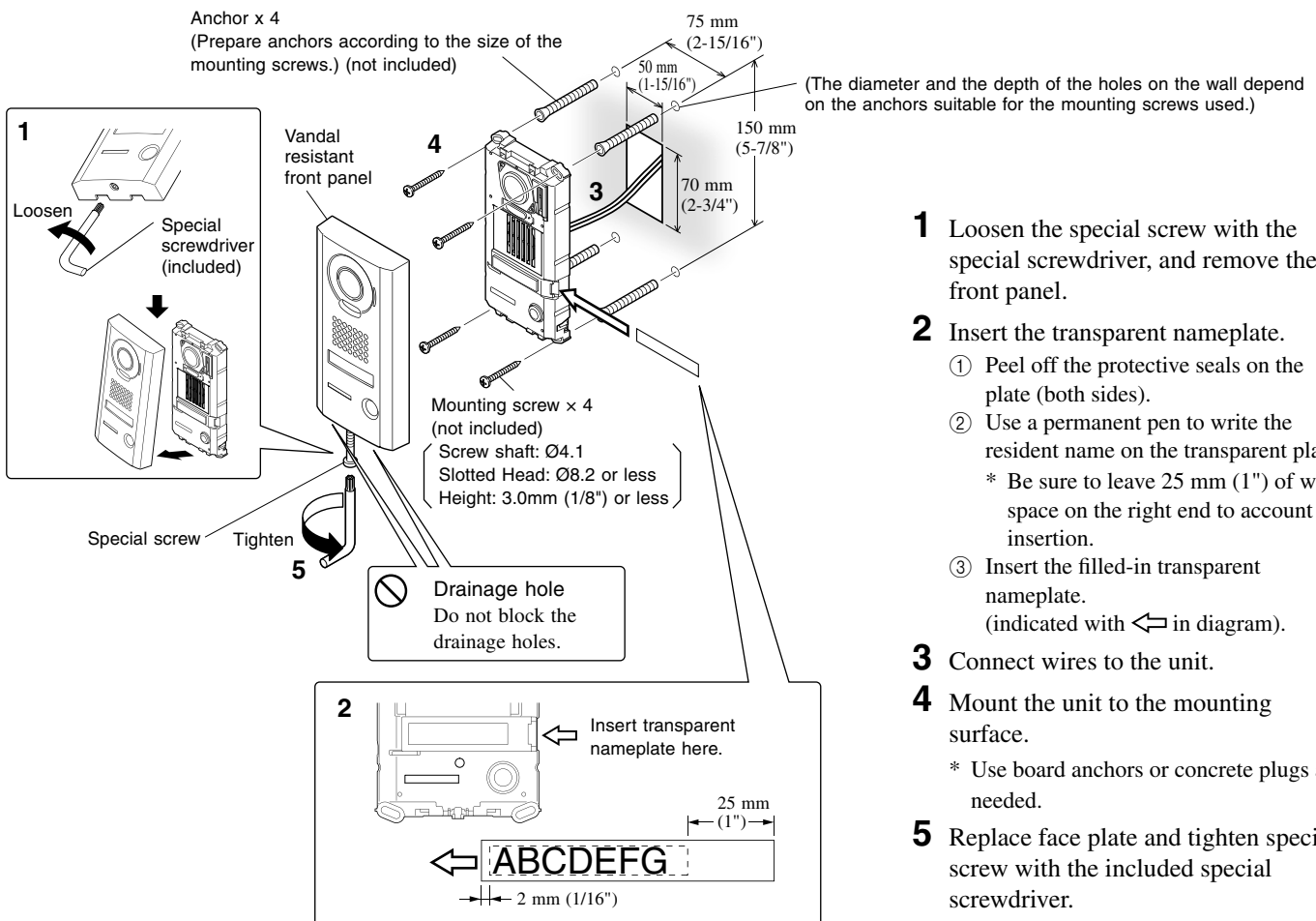

- 1** Loosen the special screw with the special screwdriver, and remove the front panel.
- 2** Insert the transparent nameplate.
 - ① Peel off the protective seals on the plate (both sides).
 - ② Use a permanent pen to write the resident name on the transparent plate.
 - * Be sure to leave 25 mm (1") of white space on the right end to account for insertion.
 - ③ Insert the filled-in transparent nameplate. (indicated with ← in diagram).
- 3** Connect wires to the unit.
- 4** Mount the unit to the mounting surface.
 - * Use board anchors or concrete plugs as needed.
- 5** Replace face plate and tighten special screw with the included special screwdriver.

JK-DA (for GT-2C-L, GT-2C only)

Refer to the installation manual included with the product.

3-10 Guard station

GT-MKB-N

When mounting on a wall

<Back wiring>

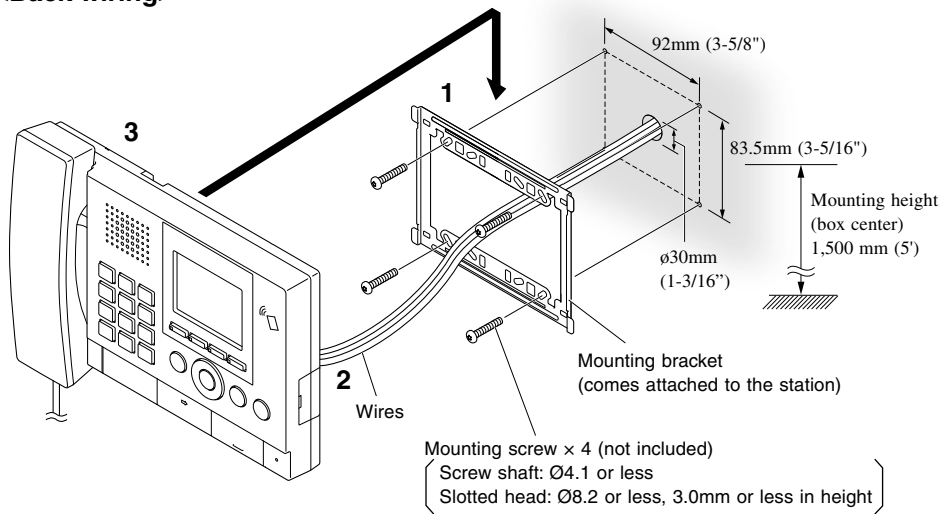

- 1 Mount the mounting bracket to the wall.
* When using a gang box, a 3-gang box is recommended.
- 2 Connect the wires to the station.
- 3 Attach the station to the mounting bracket.

<Surface wiring>

Connect the wires to the station and route them as shown in the figure.

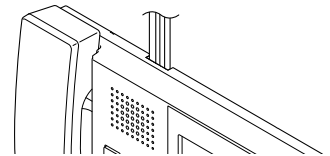

When mounting on the desktop stand

- 1 Set up the desktop stand.
* Set up the desktop stand on a level surface so that it is stabilized.
Fix the desktop stand in place if needed.
* The desktop stand can be adjusted to 3 angles.
Fit the leg in a groove on the base for the desired angle.

NOTE : Keep wiring away from NFC mark, as it may disturb the audio or video signals.

- 2 Attach the mounting bracket and insulation plate to the desktop stand.
- 3 Connect the wires to the station.
- 4 Attach the station to the mounting bracket.

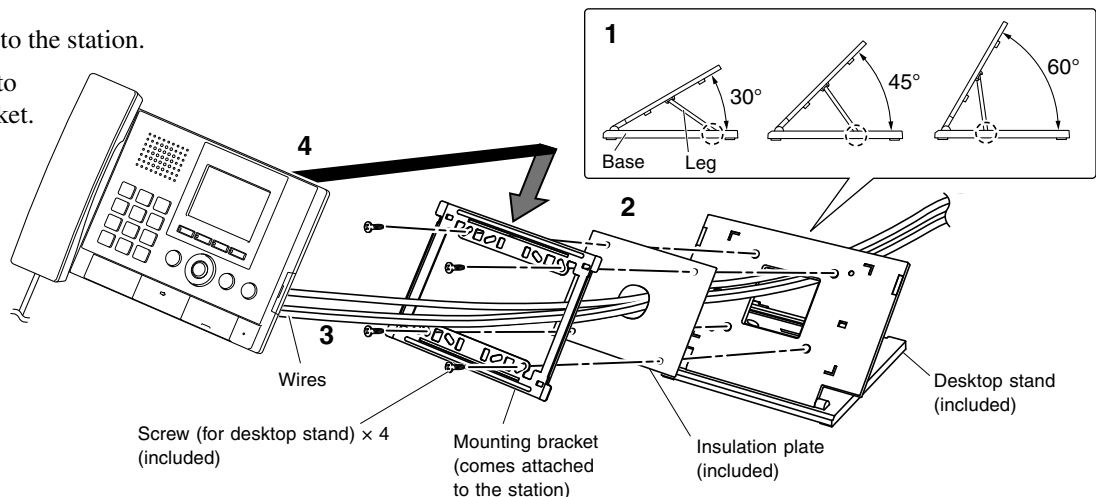

How to connect and remove wires

1. Press the release button (to insert or remove the wire).
2. Insert the wire into the terminal.

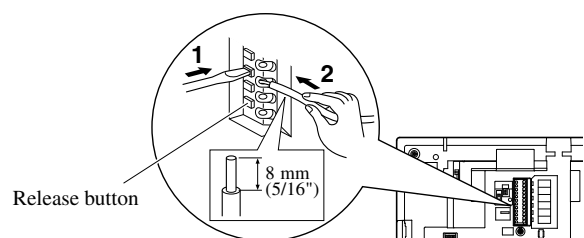

4 WIRING

4-1 Standard system

The following is an example of a basic wiring diagram for the standard system.

* The wiring methods differ depending on the equipment used. Refer to sections 4-2 to 4-4 for the detailed wiring diagrams of entrance stations, guard stations, and residential/tenant stations.

⚠ Each pair of wires should be in a separately jacketed cable (audio, video, and power wiring).

⚠ To prevent shorts, unused cables should be insulated.

NOTES:

- Do not use the unused terminals and ports for other purposes.
- In order to prevent miswiring, label both ends of each cable with the unit and terminal names to which they are to be connected.
- For connecting other manufacturers' products, refer to the instruction manuals for those products.

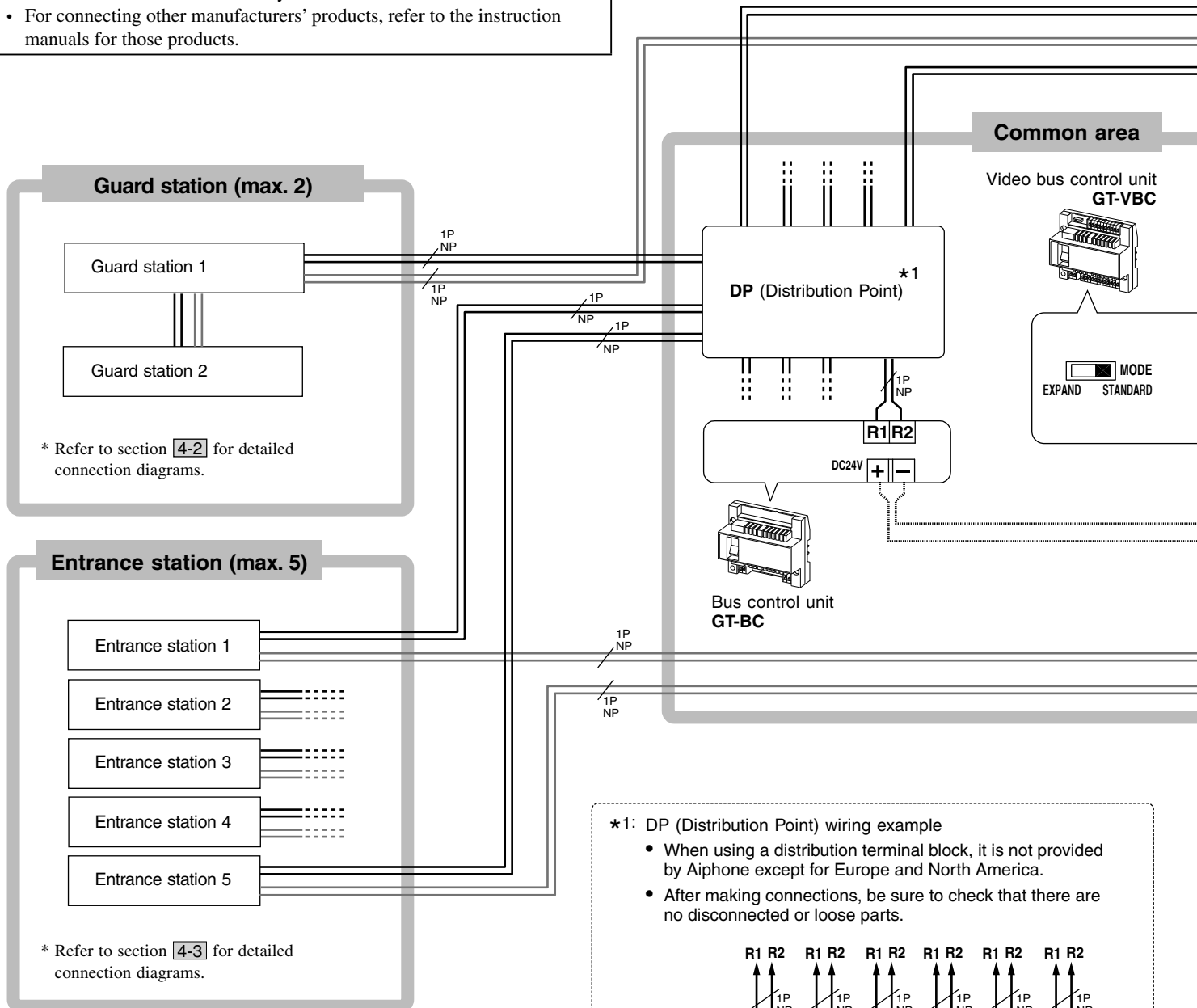

* Refer to section 4-2 for detailed connection diagrams.

* Refer to section 4-3 for detailed connection diagrams.

***1: DP (Distribution Point) wiring example**

- When using a distribution terminal block, it is not provided by Aiphone except for Europe and North America.
- After making connections, be sure to check that there are no disconnected or loose parts.

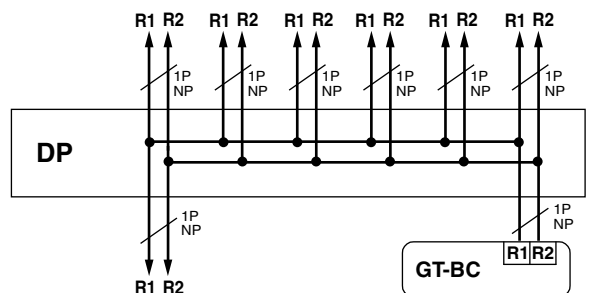

— : Audio signal line
 — : Video signal line
 : Power supply line

NP: Non-polarized

Residential/tenant trunk

* Refer to section 4-4 for detailed connection diagrams.

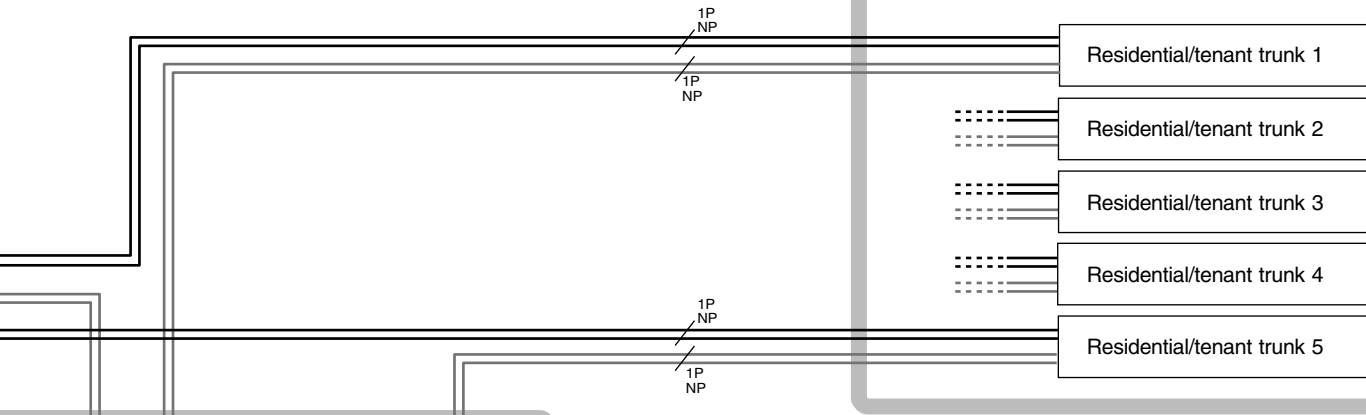

Up to two GT-VBC can be used as extension adaptors per trunk line.

- *2: To use the GT-VBC as an extension adaptor, set the MODE setting switch to [EXPAND].
- *3: The wires must be connected to the IN (1) terminals.

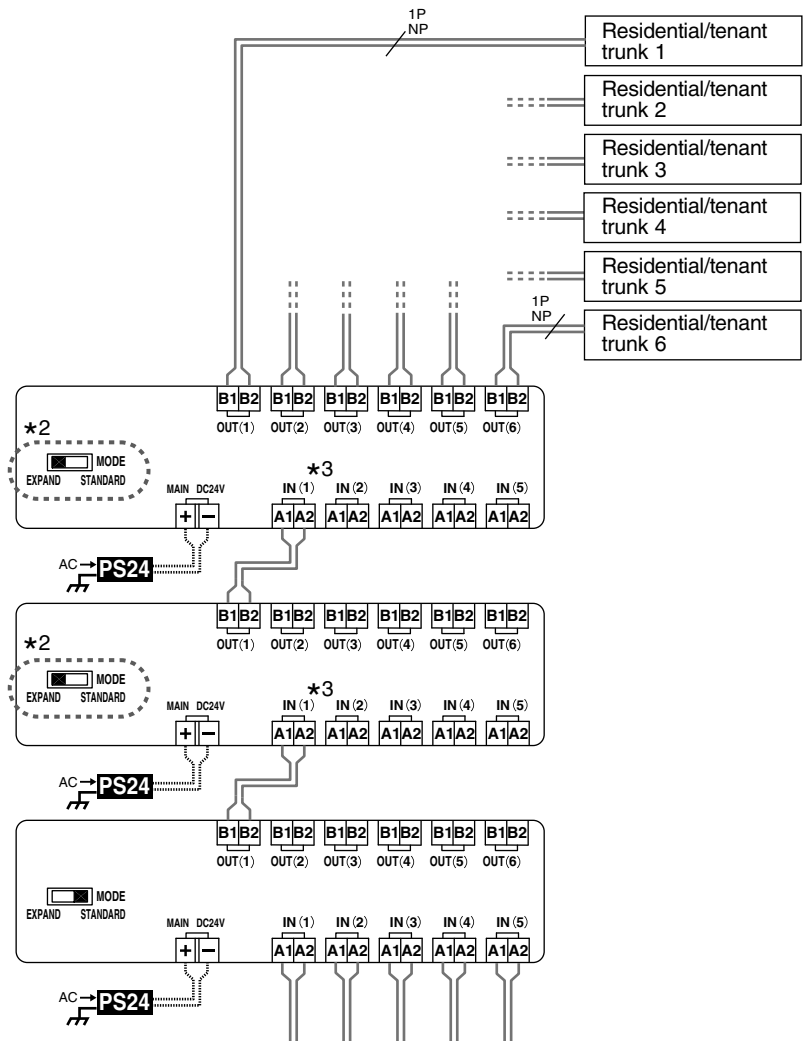
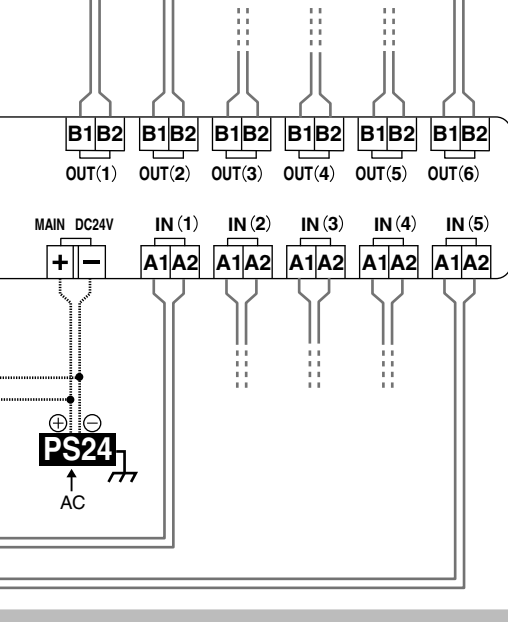

PS24

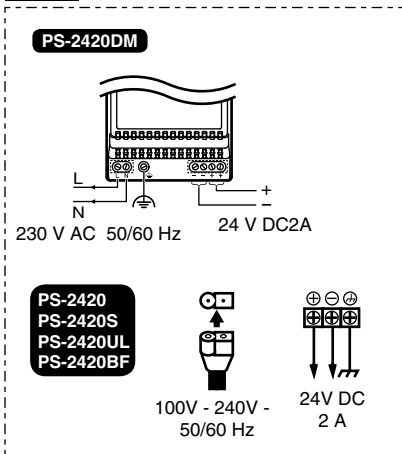



(Please note that images and terminal position in this manual may differ from the actual product.)

4-2 Guard station

NOTES:

- Refer to section 4-7 for option connector details.
- Refer to section 5-1 for the switch settings.

 : Audio signal line
 : Video signal line
 : Power supply line

P: Polarized
 NP: Non-polarized

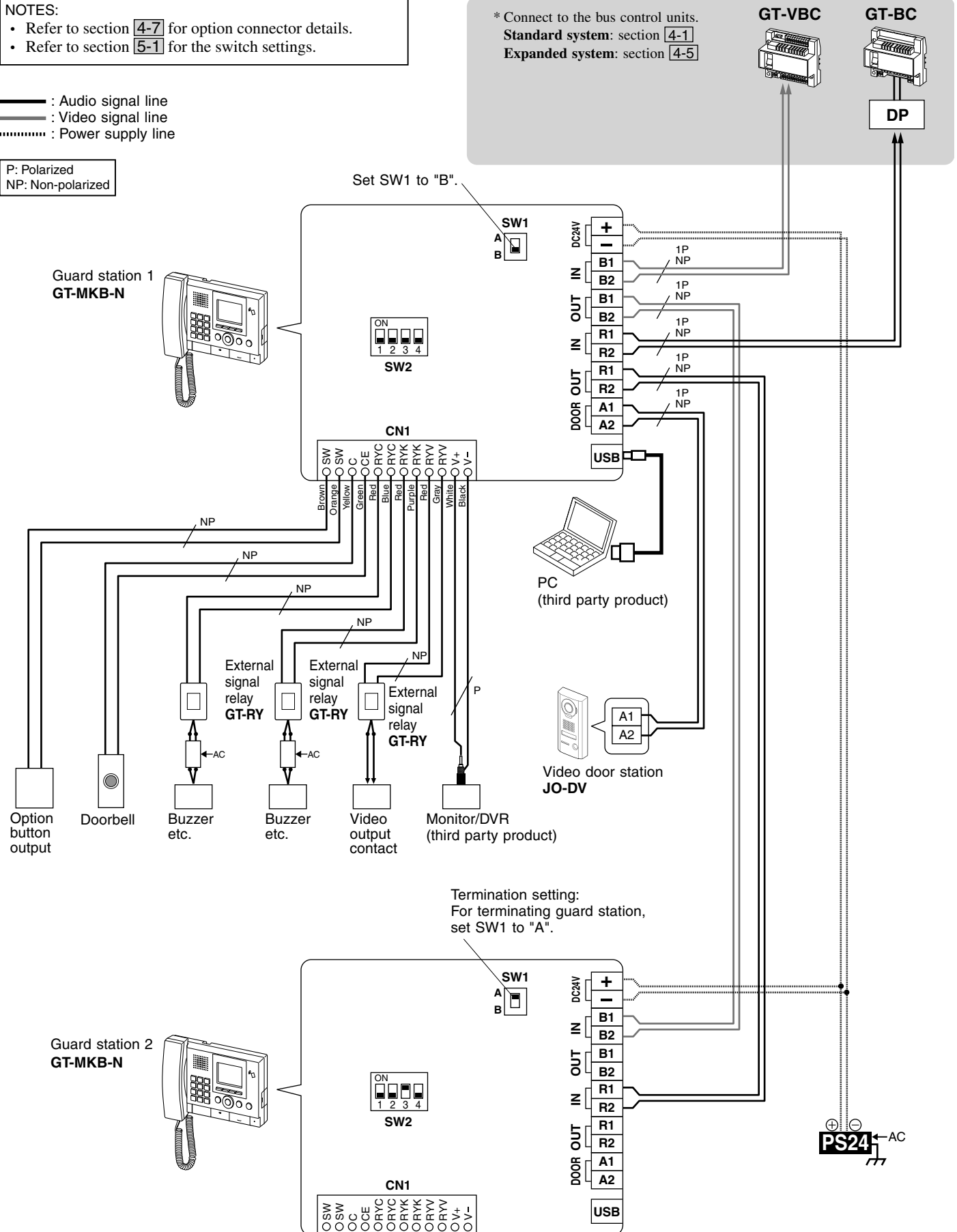

(Please note that images and terminal position in this manual may differ from the actual product.)

4-3 Entrance station

Modular type and all-in-one type entrance stations are available. The wiring method differs depending on the type or the combination of modular units, as shown below.

■ Modular type (video and audio)

Modular unit combination example

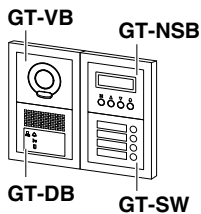
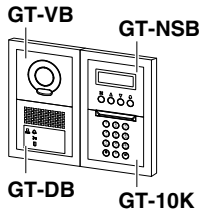

(*1): N/C (Normally Closed) [ELB, ELC]
N/O (Normally Open) [ELM, ELC]
Less than AC/DC 24V, 4A (resistive load)
(*2): GT-DB-V and GT-DB-VN only.

NOTES:

- Refer to section 4-7 for option connector details.
- Refer to section 5-1 for the switch settings.

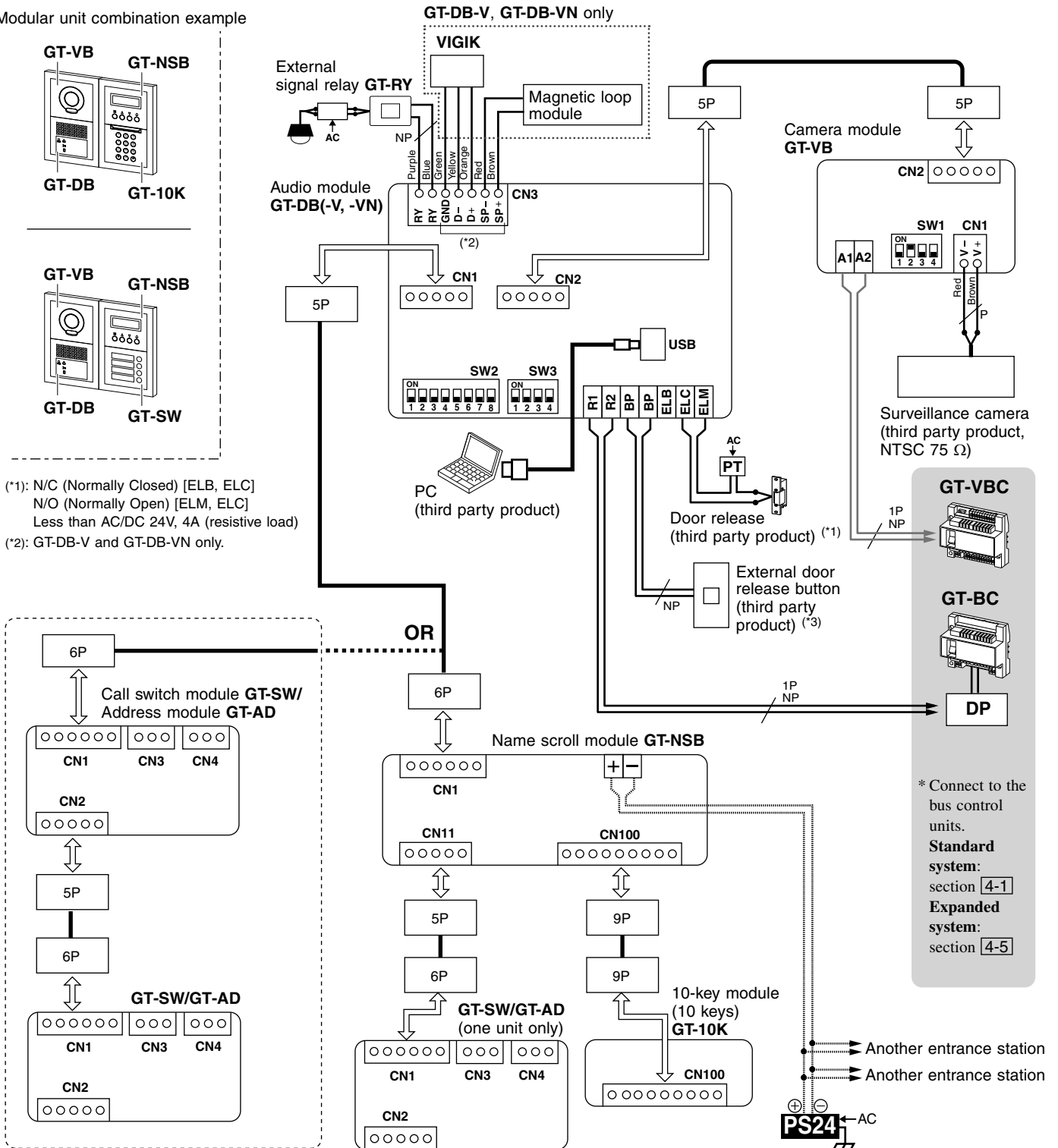

(*3): Input specifications

Input method	N/O (Normally Open) contact
Detection confirmation time	100 ms or more
Closed contact resistance	1 kΩ or less
Open contact resistance	50 kΩ or more
Terminal short current	10 mA or less
Open circuit voltage between terminals	3.3 V DC or less

(Please note that images and terminal position in this manual may differ from the actual product.)

— : Audio signal line
— : Video signal line
..... : Power supply line

P: Polarized
NP: Non-polarized

■ All-in-one type

NOTE: Refer to section [5-1](#) for the switch settings.

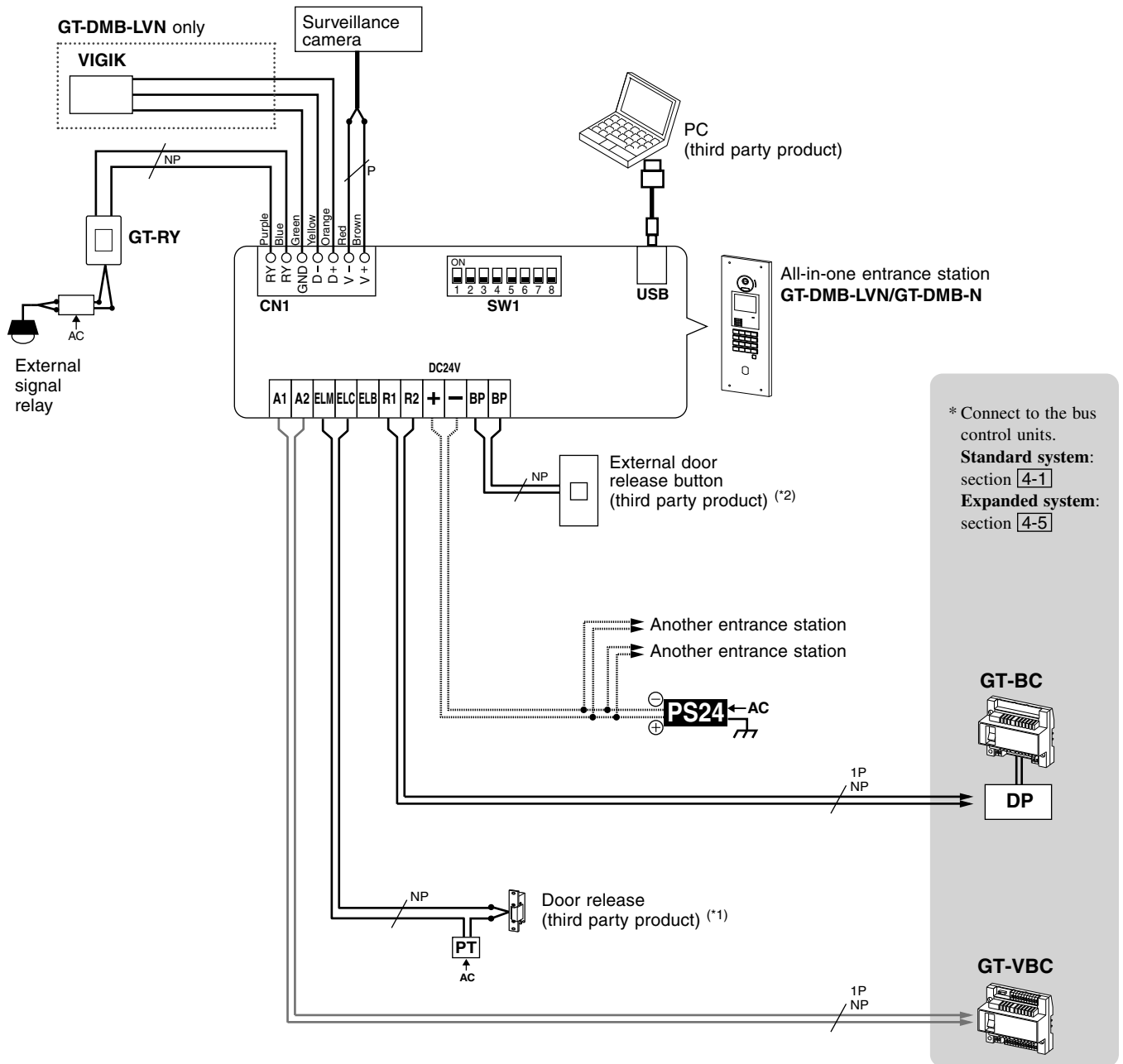

(*1): N/C (Normally Closed) [ELB, ELC]
N/O (Normally Open) [ELM, ELC]
Less than AC/DC 24V, 4A (resistive load)

(*2): **Input specifications**

Input method	N/O (Normally Open) contact
Detection confirmation time	100 ms or more
Closed contact resistance	1 kΩ or less
Open contact resistance	50 kΩ or more
Terminal short current	10 mA or less
Open circuit voltage between terminals	3.3 V DC or less

— : Audio signal line
- - - : Video signal line
..... : Power supply line

NP: Non-polarized
P: Polarized

(Please note that images and terminal position in this manual may differ from the actual product.)

4-4 Residential/tenant trunk

NOTE: This system allows 3 types of connection methods: "Loop wiring method", "GT-4Z wiring method", and "GT-1Z wiring method".
Select the method suitable for the application and usage of the system.

Loop wiring method

GT-2C-L/GT-2C, GT-2H-L/GT-2H

* Refer to section 4-7 for details about the option connector.

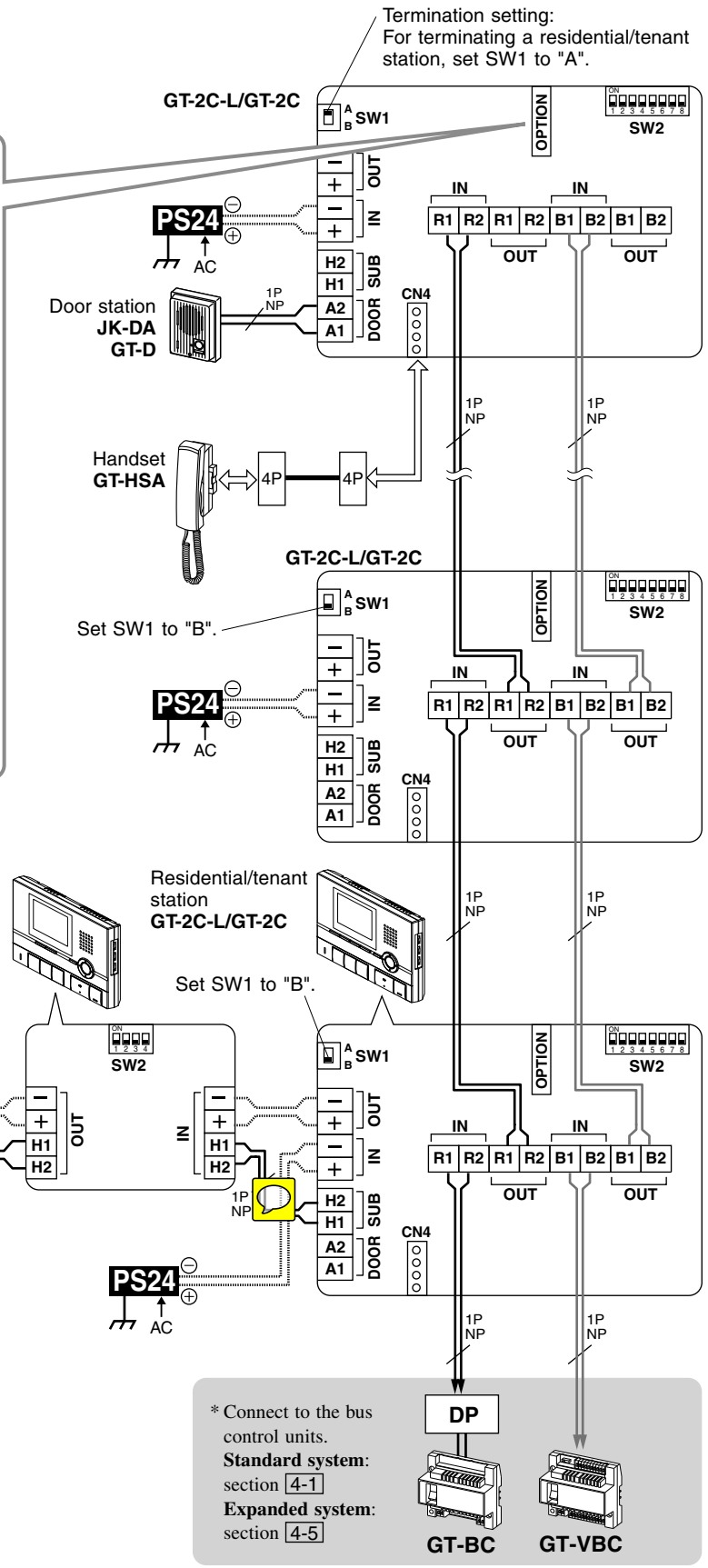
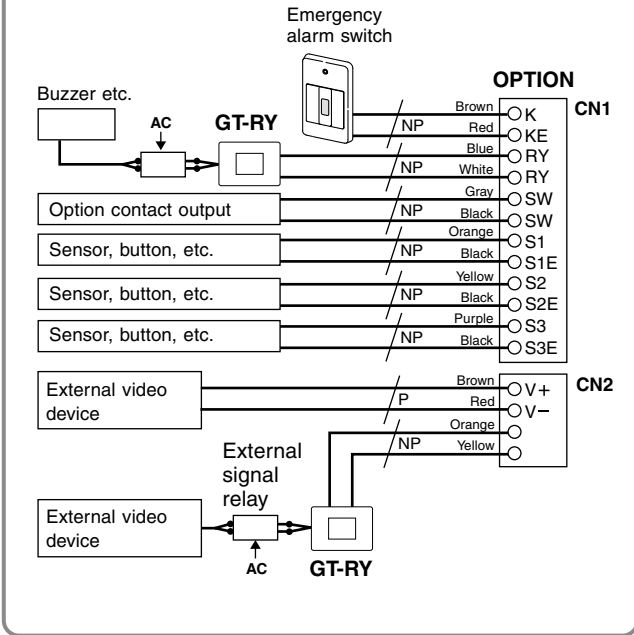

Termination setting:
For terminating sub residential/tenant station, turn 4 on SW2 to ON.

- NOTES:
- Refer to section 4-7 for details about wiring to the option connector.
 - Refer to section 5-2 for the switch settings.

⚠ After connecting a residential/tenant station and a door station (or doorbell), power cycle the unit.

- : Audio signal line
 - : Video signal line
 - : Power supply line
- NP: Non-polarized
P: Polarized

(Please note that images and terminal position in this manual may differ from the actual product.)

Loop wiring method

GT-1C7-L/GT-1C7, GT-1M3-L/GT-1M3

⚠ Turn off the GT-BC control unit before connecting wires. Failure to do so could damage the station.

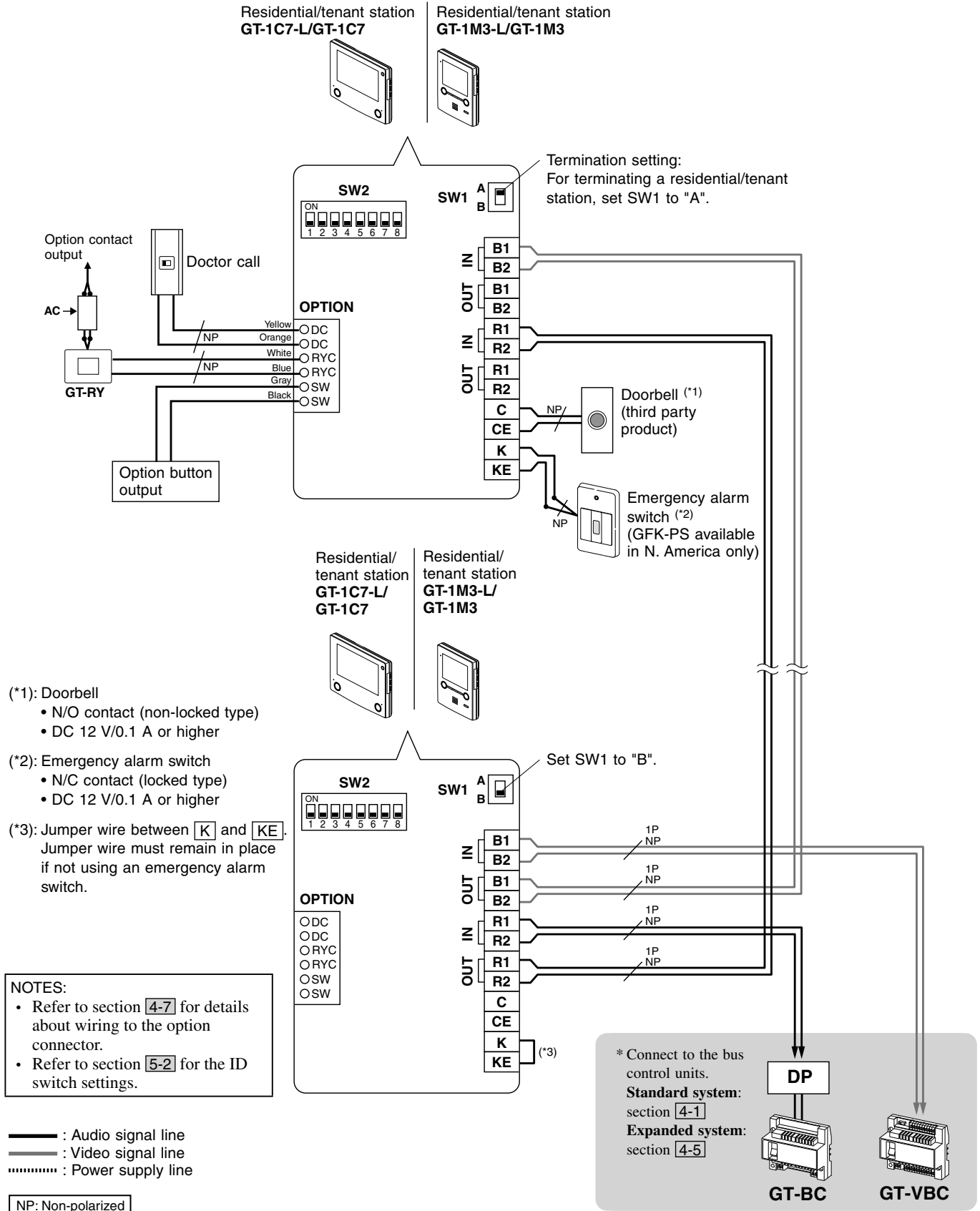

(Please note that images and terminal position in this manual may differ from the actual product.)

Loop wiring method

GT-1C7W-L/GT-1C7W

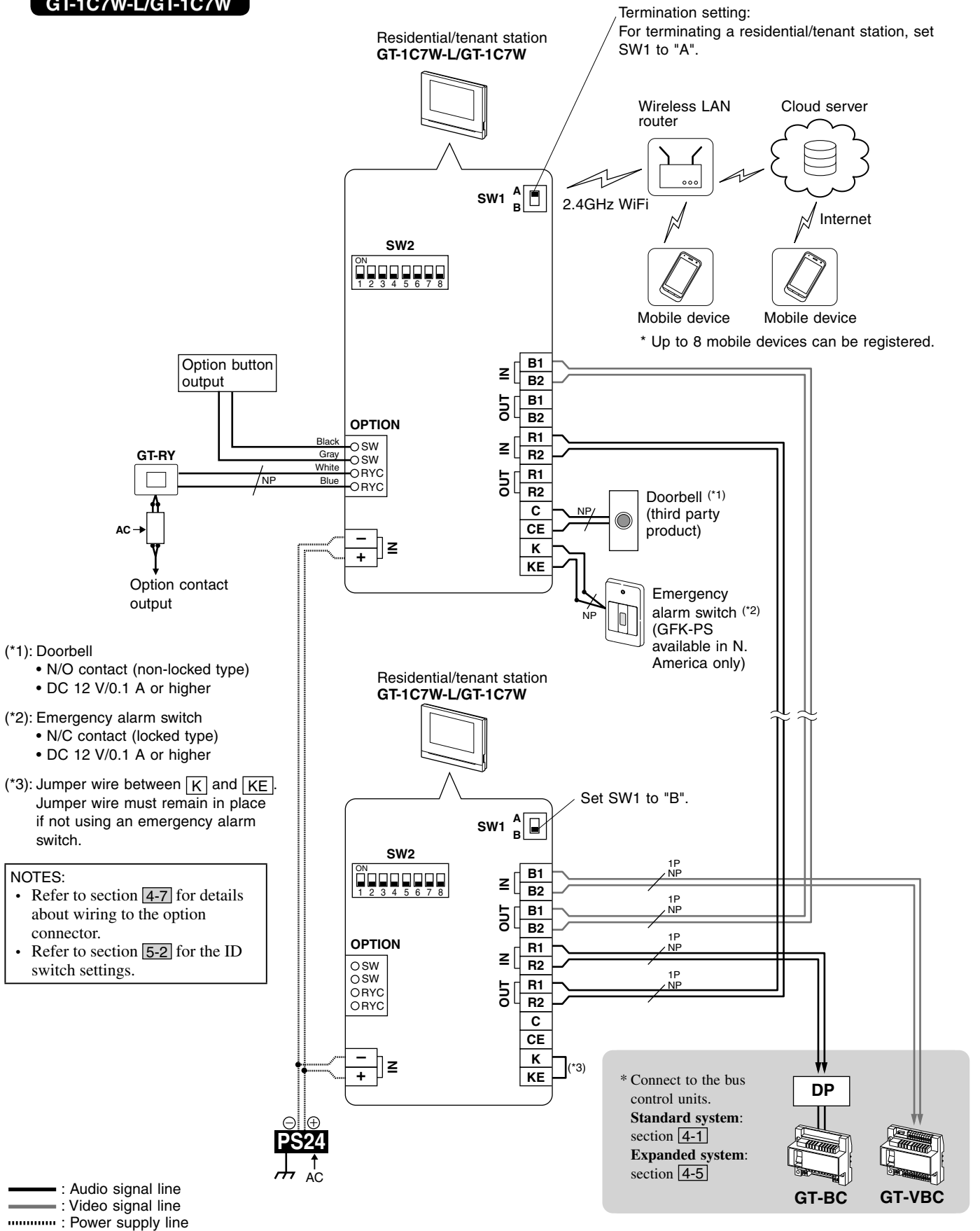

(*1): Doorbell
• N/O contact (non-locked type)
• DC 12 V/0.1 A or higher

(*2): Emergency alarm switch
• N/C contact (locked type)
• DC 12 V/0.1 A or higher

(*3): Jumper wire between [K] and [KE].
Jumper wire must remain in place if not using an emergency alarm switch.

NOTES:

- Refer to section 4-7 for details about wiring to the option connector.
- Refer to section 5-2 for the ID switch settings.

(Please note that images and terminal position in this manual may differ from the actual product.)

■ GT-1Z wiring method (using the video 1-zone divider)

GT-2C-L/GT-2C, GT-1C7-L/GT-1C7, GT-1M3-L/GT-1M3, GT-1C7W-L/GT-1C7W

* The following diagram is a wiring example using the residential/tenant stations GT-1C7-L/GT-1C7 and GT-1M3-L/GT-1M3.

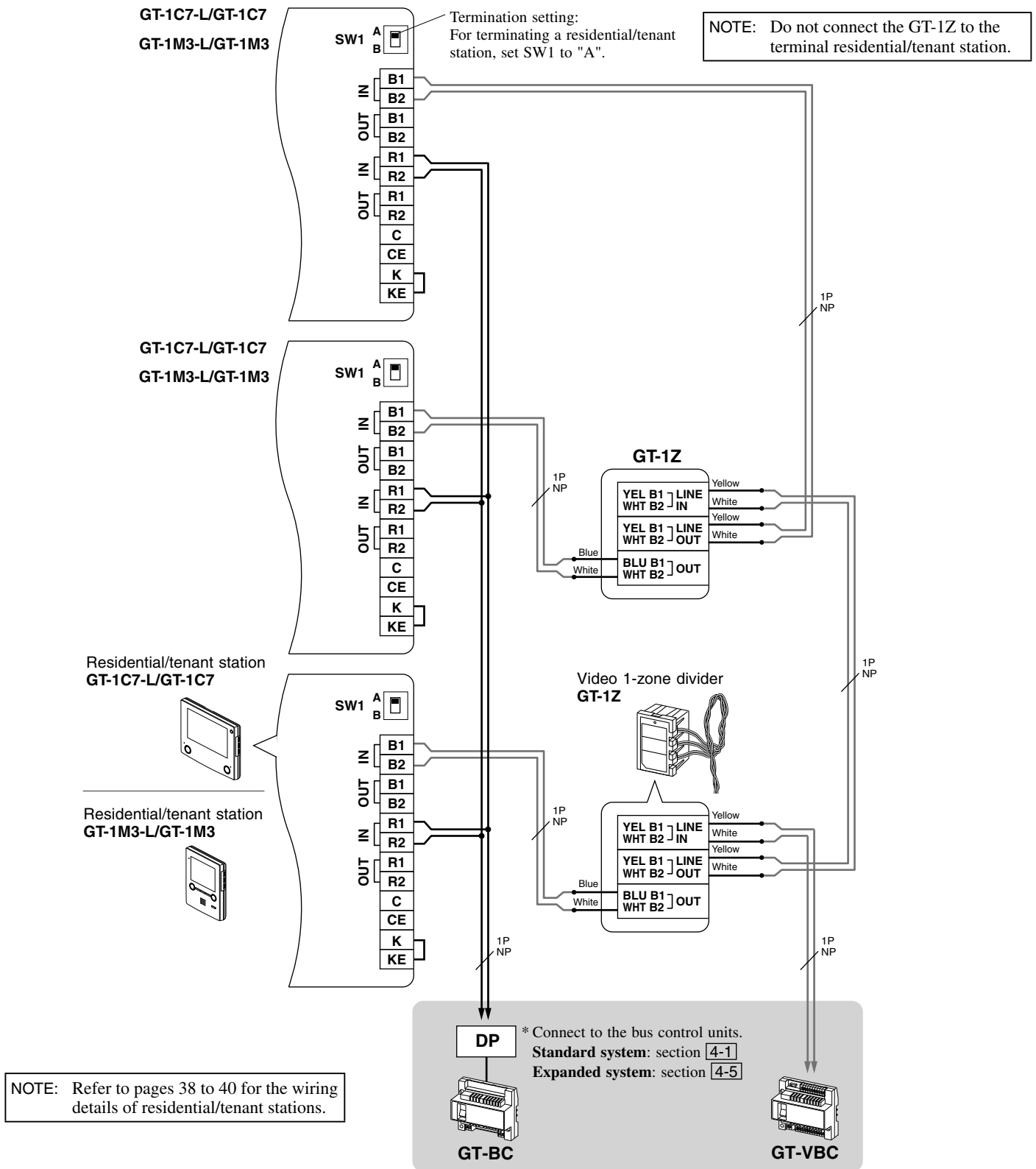

(Please note that images and terminal position in this manual may differ from the actual product.)

GT-1A

NOTE: Refer to section 4-7 for details about wiring to the option connector.

Residential/tenant station (audio only)

GT-1A

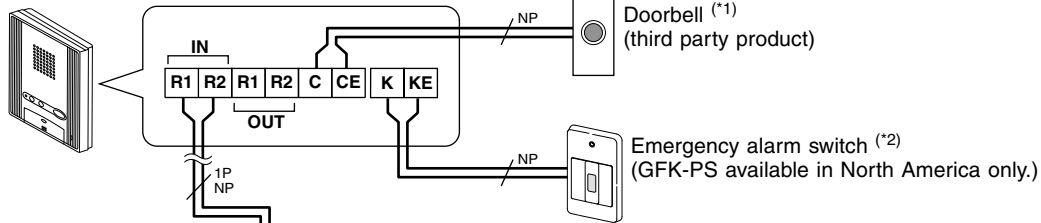

GT-1A

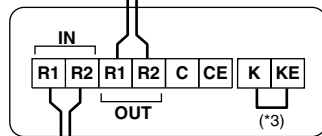

1P
NP

DP

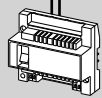

GT-BC

* Connect to the audio bus control unit.

Standard system: section 4-1

Expanded system: section 4-5

(No connection is needed to the video bus control unit GT-VBC.)

(*1): Doorbell

- N/O contact (non-locked type)
- DC 12 V/0.1 A or higher

(*2): Emergency alarm switch

- N/C contact (locked type)
- DC 12 V/0.1 A or higher

(*3): Jumper wiring between **K** and **KE**.

Jumper wire must remain in place if not using an emergency alarm switch.

NP: Non-polarized

GT-1D

NOTES:

- Refer to section 4-7 for details about wiring to the option connector.
- To connect wires, the case must be removed from the chassis. Refer to section 3-7 for how to remove the case.

- ⚠ Turn off the GT-BC control unit before connecting wires. Failure to do so could damage the station.
- ⚠ Be careful not to damage the circuit board when connecting wires and mounting the station. Failure to do so could damage the station.

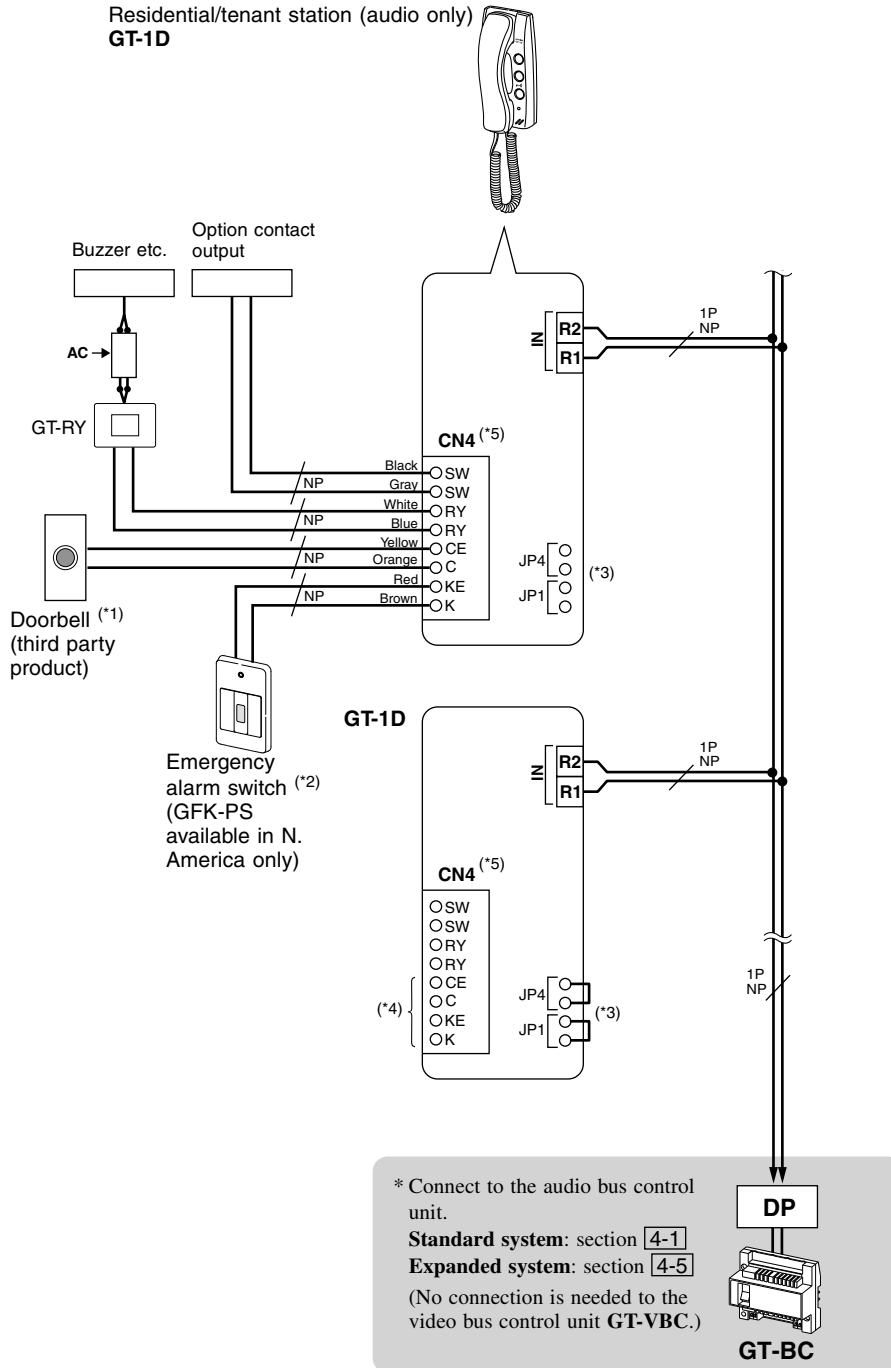

- (*1): Doorbell
- N/O contact (non-locked type)
 - DC 12 V/0.1 A or higher
- (*2): Emergency alarm switch
- N/C contact (locked type)
 - DC 12 V/0.1 A or higher
- (*3): When using an emergency alarm switch, remove the jumper wire from the JP1 connectors. Otherwise, leave the jumper wire connected.
- When using Doctor call, remove the jumper wire from the JP4 connectors. Otherwise, leave the jumper wire connected.
- (*4): Only one emergency alarm switch and one doorbell can be connected to the same station. Each station uses its own option connector for external devices used for that tenant.
- (*5): When making a connection to the CN4 connector, remove the protective cap.



4-5 Expanded system

Common trunk line 1

Guard station

* Refer to section 4-2 for detailed connection diagrams.

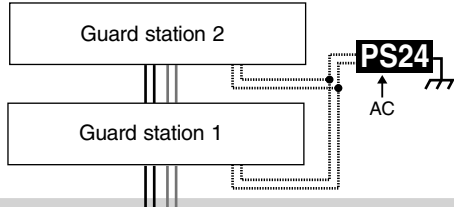

Entrance station

* Refer to section 4-3 for detailed connection diagrams.

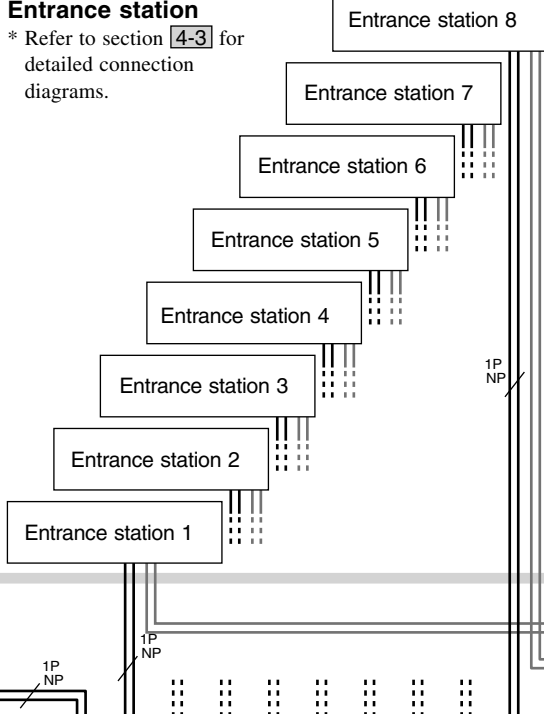

DP (Distribution Point)
(Not provided by Aiphone except for Europe and North America.)

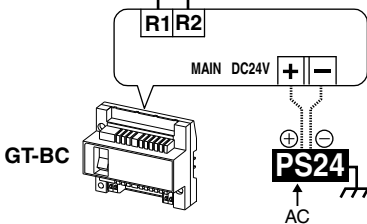

- ⚠ Use two separately jacketed 2 conductor cables for the audio and video connections.
- ⚠ To prevent shorts, unused cables should be insulated.
- ⚠ Do not connect 2 or more GT-BC units on the same trunk line.

Sub trunk line 1-A

* Make connections in the same method with the sub trunk line 2-B.

Sub trunk line 1-B

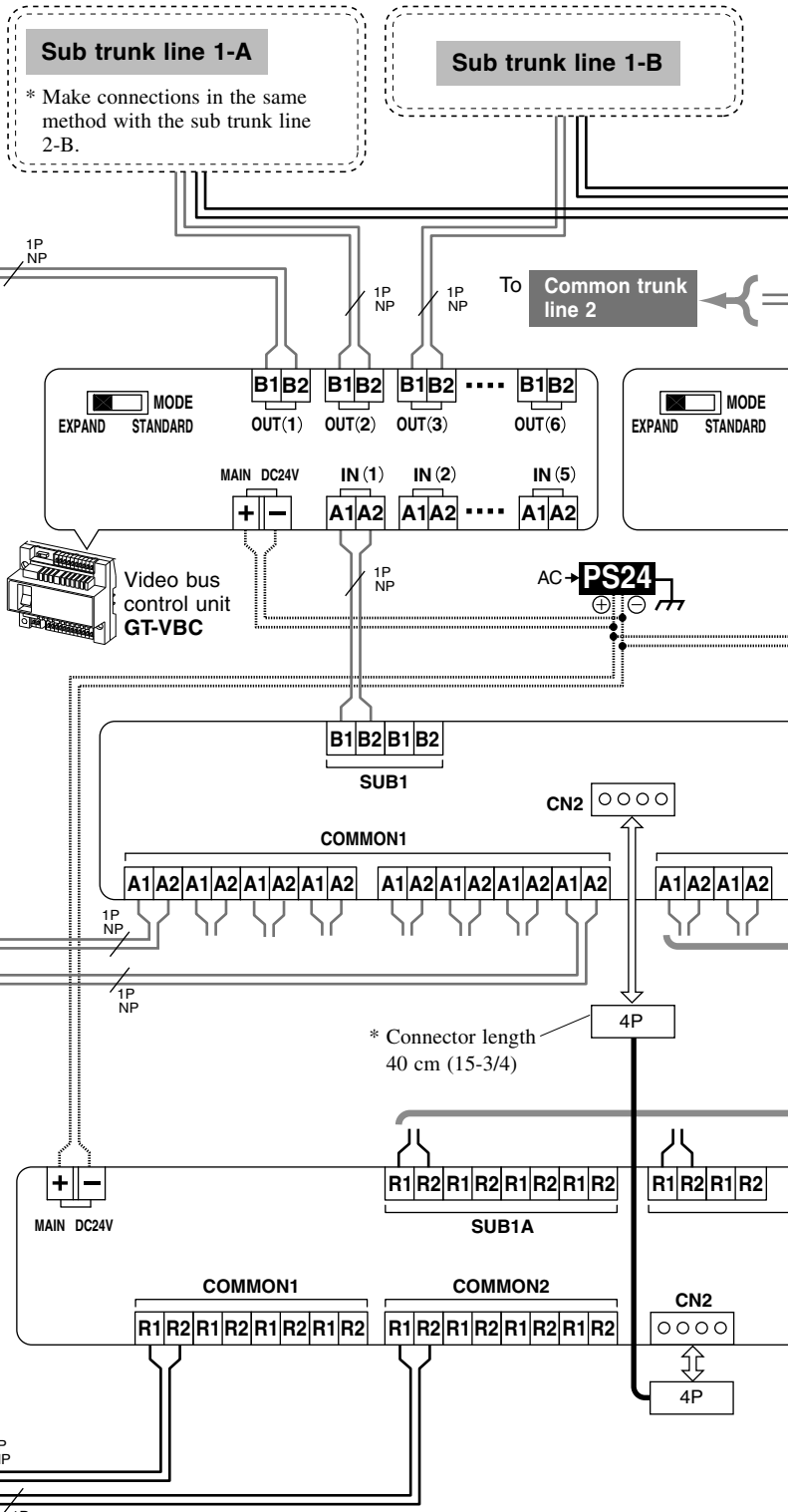

* Connector length 40 cm (15-3/4)

Common trunk line 2

* Use the same method for connecting each common trunk line.

To GT-VBX

To GT-VBC

4-6 Lift control system (for expanded system only)

Max. 16 adaptors (GTW-LC) can be connected to a system.

*Max. 8 adaptors (GTW-LC) per trunk.

NOTE: Refer to section 5-1 for the ID switch settings.

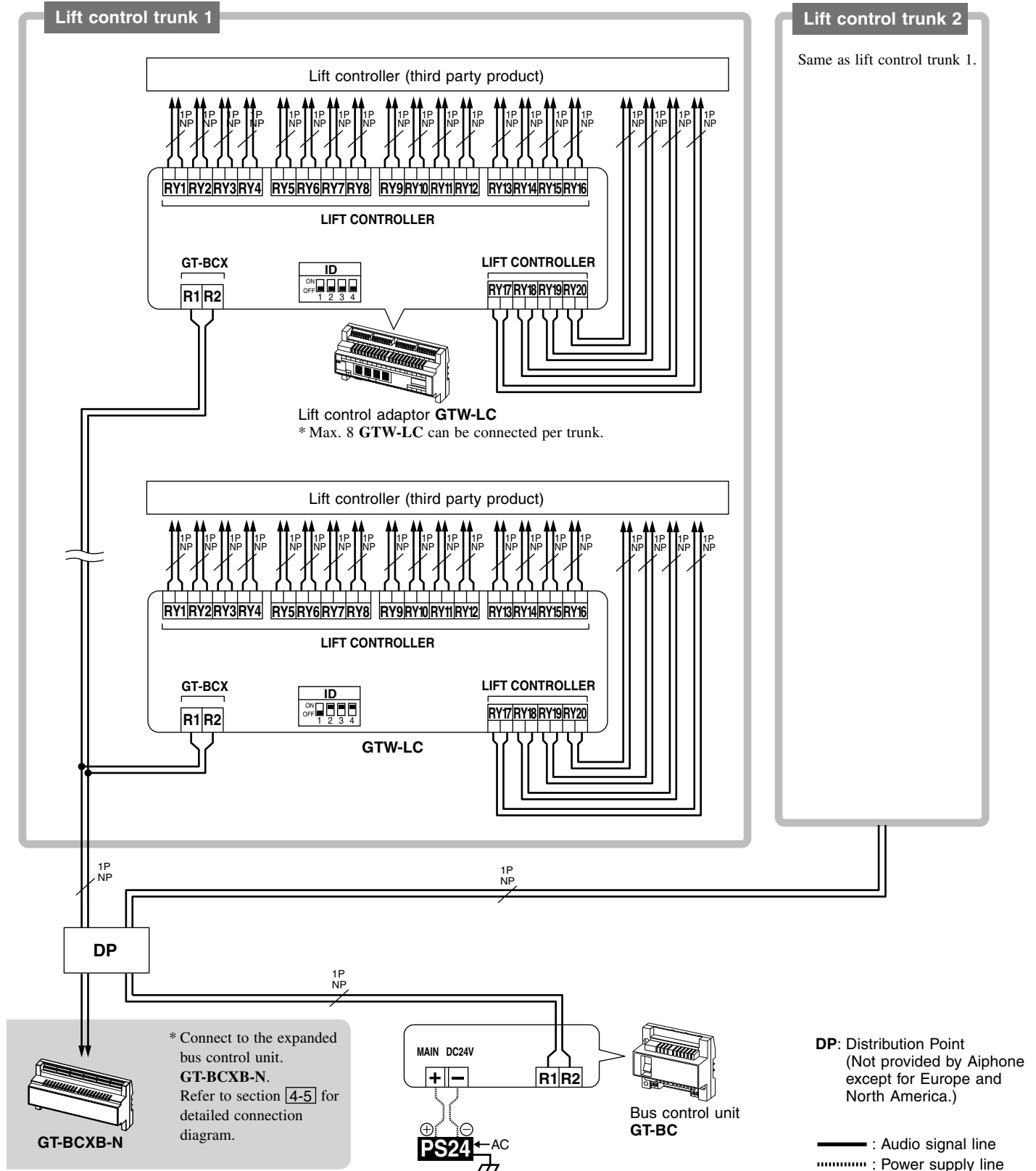

4-7 Option connector

⚠ To prevent shorts, be sure to cut unused lead wires and insulate the ends.

⚠ Installation setting is necessary for the GT-2C-L/GT-2C. Refer to the GT SYSTEM Setting manual to perform the settings.

GT-2C-L/GT-2C

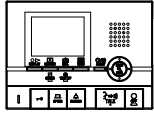

12-pin option connector

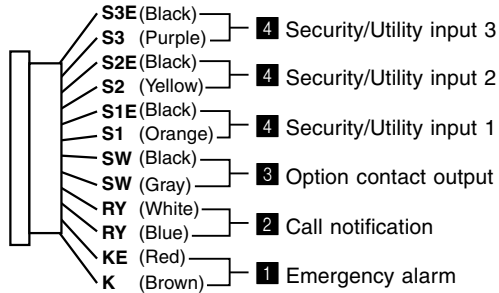

4-pin option connector (not included)

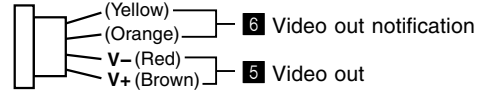

GT-1C7-L/GT-1C7

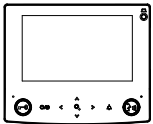

GT-1M3-L/GT-1M3

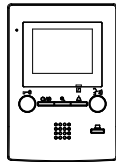

Option connector

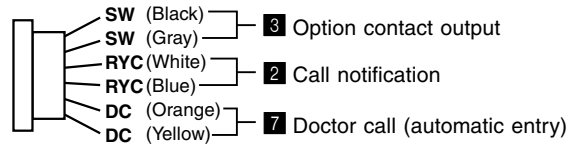

GT-1C7W-L/GT-1C7W

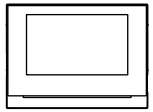

Option connector

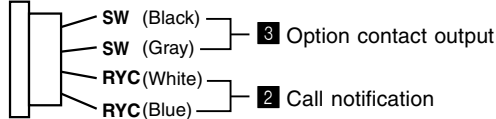

GT-1D

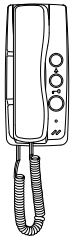

Option connector

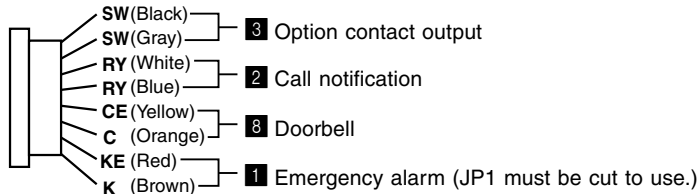

GT-MKB-N

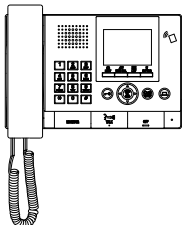

Option connector

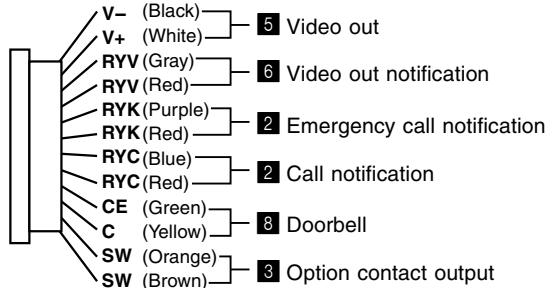

GT-1A

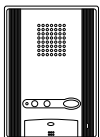

Option connector

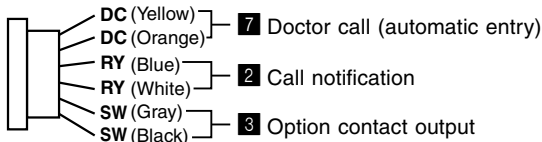

1 Emergency alarm

An emergency alarm switch can be connected.

GT-2C-L/GT-2C, GT-1D	N/C contact (locked type) DC 12 V/0.1 A or higher
GT-2C-L/GT-2C	N/O contact (non-locked type) DC 12 V/0.1 A or higher

2 Call notification/Emergency call notification

Using the external signaling relay GT-RY allows for an external buzzer to be linked during calling.

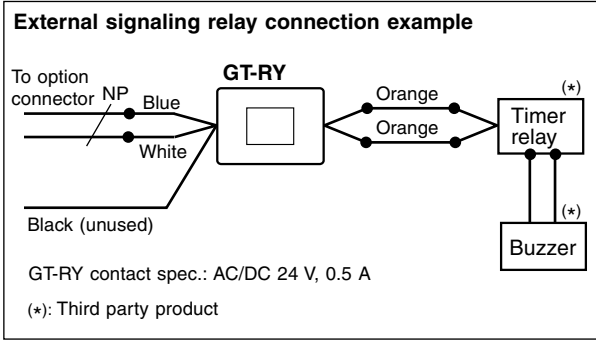

3 Option contact output

External units such as lights or elevators can be operated with the option button.

Contact spec.: Maximum load AC/DC 24 V, 1 A
 Minimum load DC 5 V, 0.1 A

4 Security/Utility inputs 1 to 3

Input method	N/O (Normally Open) or N/C (Normally Closed) contact External sensor input (start signal only detection method)
Detection confirmation time	100 msec or more
Contact resistance	N/O: 1 kΩ or less N/C: 50 kΩ or more
Terminal short current	1 mA or less
Voltage between terminals	DC 3.3 V or less (when open between terminals)

5 Video out

Video can be output to DVR's, etc.

NTSC, 1 Vp-p/75 Ω

Wiring distance: 3 m

NOTE: The screen playing recorded pictures is not output.

6 Video out notification

External monitors can be activated via the external signaling relay GT-RY.

GT-RY contact spec.: AC/DC 24 V, 0.5 A

7 Doctor call (automatic entry)

This makes it possible to use the doctor call (automatic entry) function at residential/tenant stations.

To enable the doctor call:

GT-1C7-L/GT-1C7, GT-1M3-L/ GT-1M3, GT-1A	Short the DC terminal.
GT-1D	Cut (open) the jumper JP4.

8 Doorbell

A doorbell can be connected to a residential/tenant station.

N/O contact (non-locked type)

DC 12 V/0.1 A or higher

NOTE: One doorbell per residential/tenant station. Do not connect two or more doorbells to a residential/tenant station.

5 SETTINGS

The settings of each unit can be configured manually by setting the switches, as described below.

* It is recommended to discuss the installation and setting method with the person responsible for installation in advance.

5-1 Switch settings

■ Entrance station (modular type)

Audio module (GT-DB, GT-DB-V, GT-DB-VN)

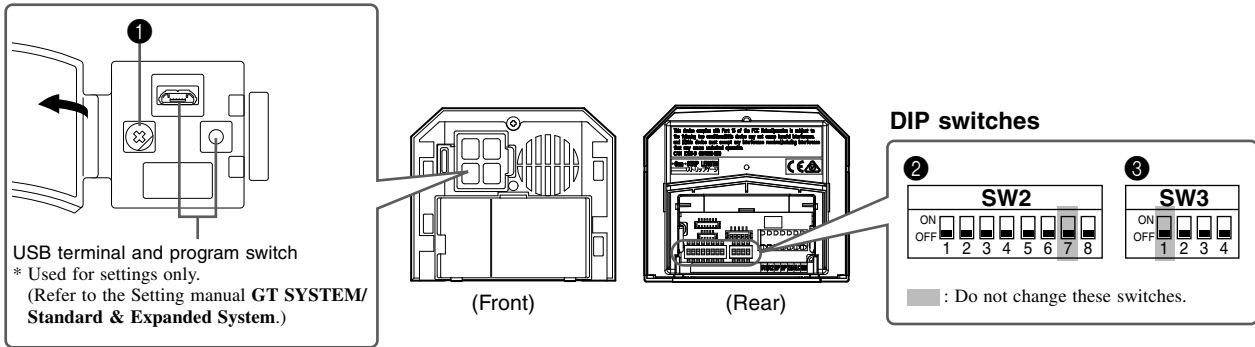

① VR1 dial (inside the cover)

Function	Default
Sets the door release duration time. Setting range: M (Momentary)/0.5-20 seconds	M (Momentary)

② SW2

No.	Function	Default
1	Sets this entrance station as used for either a multi building system or single building system. ON: Multi building system OFF: Single building system	OFF
2 to 4	Sets the ID of this entrance station. * (9) - (16): GT-BCXB-N Common trunk line 2 ID number Positions of switch 2 to 4	2: OFF 3: OFF 4: OFF (ID 1)
5	Sets the ability of this entrance station to be monitored by the guard station or residential/tenant station. ON: Allowed OFF: Not allowed	OFF
6	* This setting is needed only in France. Set the transmission method for VIGIK. ON: HEXACT® version OFF: AIPHONE version	OFF
8	Resets the passcode for installer or administrator when this unit is initialized by setting this switch to ON.	OFF

② SW3

No.	Function	Default
2 to 4	Sets the language for audio guidance by the combination of the switch 2 to 4 settings. (No guidance) English French German Spanish Dutch Norwegian (Tone)	2: OFF 3: OFF 4: OFF (No guidance)

Camera module (GT-VB)

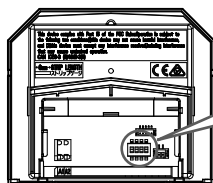

DIP switches

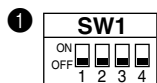

1 SW1

No.	Function	Default
1	Sets the night illumination. ON: Always off OFF: Turns on/off automatically	OFF
2	Sets whether surveillance camera or light is attached. ON: Surveillance camera OFF: Light control	OFF
3 to 4	Sets the display mode at the beginning of a call. <div style="display: flex; justify-content: space-around;"> <div style="text-align: center;"> <p>Zoom</p> </div> <div style="text-align: center;"> <p>Wide</p> </div> </div> <p>Positions of switch 3 and 4</p> <p>Zoom (3 seconds) → Wide</p> <p>Wide (3 seconds) → Zoom</p>	3: OFF 4: OFF (Zoom)

Entrance station (all-in-one type)

GT-DMB-LVN, GT-DMB-N

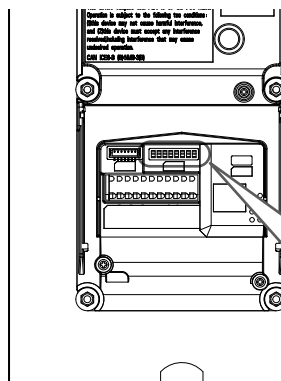

DIP switches



■ : Do not change these switches.

1 SW1

No.	Function	Default
1	Sets this entrance station as used for either a multi building system or single building system. ON: Multi building system OFF: Single building system	OFF
2 to 4	Sets the ID of this entrance station. * (9) - (16): GT-BCXB-N Common trunk line 2 ID number Positions of switch 2 to 4 	2: OFF 3: OFF 4: OFF (ID 1)
7	Sets the event that triggers LCD. Sensor detection Operation of this unit 	OFF (Sensor detection)
8	Resets the passcode for the installer or administrator when this unit is initialized by setting this switch to ON in 2 seconds.	OFF

Guard station

GT-MKB-N

DIP switches

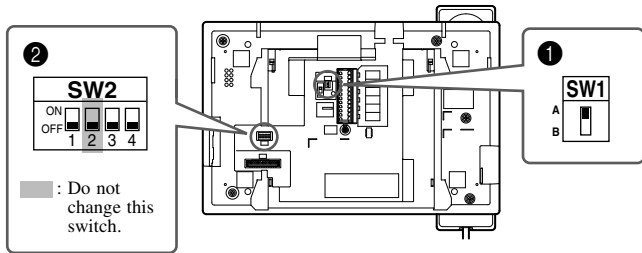

1 SW1

Function	Default
For terminating a guard station, set SW1 to "A". When not terminating, set to "B".	A

2 SW2

No.	Function	Default
1	Sets this unit as used for either a multi building system or single building system. ON: Multi building system OFF: Single building system	OFF
3	Sets the ID of this unit. * (3), (4): GT-BCXB-N Common trunk line 2 ON: ID 2 (4) OFF: ID 1 (3)	OFF (ID 1)
4	Resets the passcode for installer or administrator when this unit is initialized by setting this switch to ON in 2 seconds.	OFF

Expanded bus control unit

GT-BCXB-N

Power switch

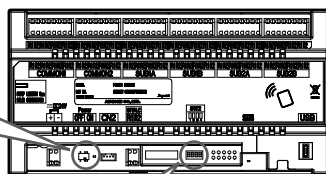
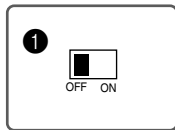

DIP switch

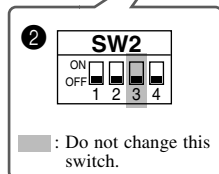

1 Power switch

Set the switch to ON when using this unit.

2 SW2

No.	Function	Default
1	Sets this unit as used for either a multi building system or single building system. ON: Multi building system OFF: Single building system	OFF
2	Sets this unit as to be used for either a tenant section or main section. ON: Main section OFF: Tenant section	OFF
4	Resets the passcode for installer or administrator when this unit is initialized by setting this switch to ON in 2 seconds.	OFF

Lift control adaptor

GTW-LC

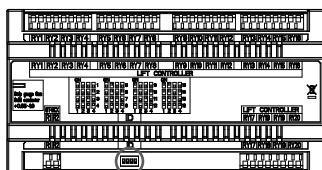

ID switch

Set the lift control ID number of this unit by the combination of the switch 1 to 4 settings as shown below.

ID number



Positions of switch 1 to 4

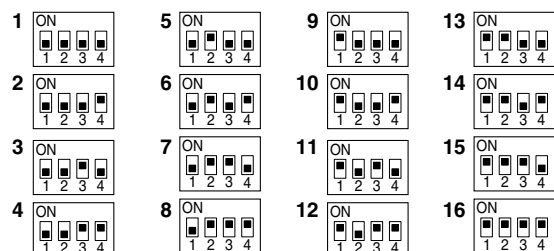

5-2 Switch settings (for residential/tenant stations only)

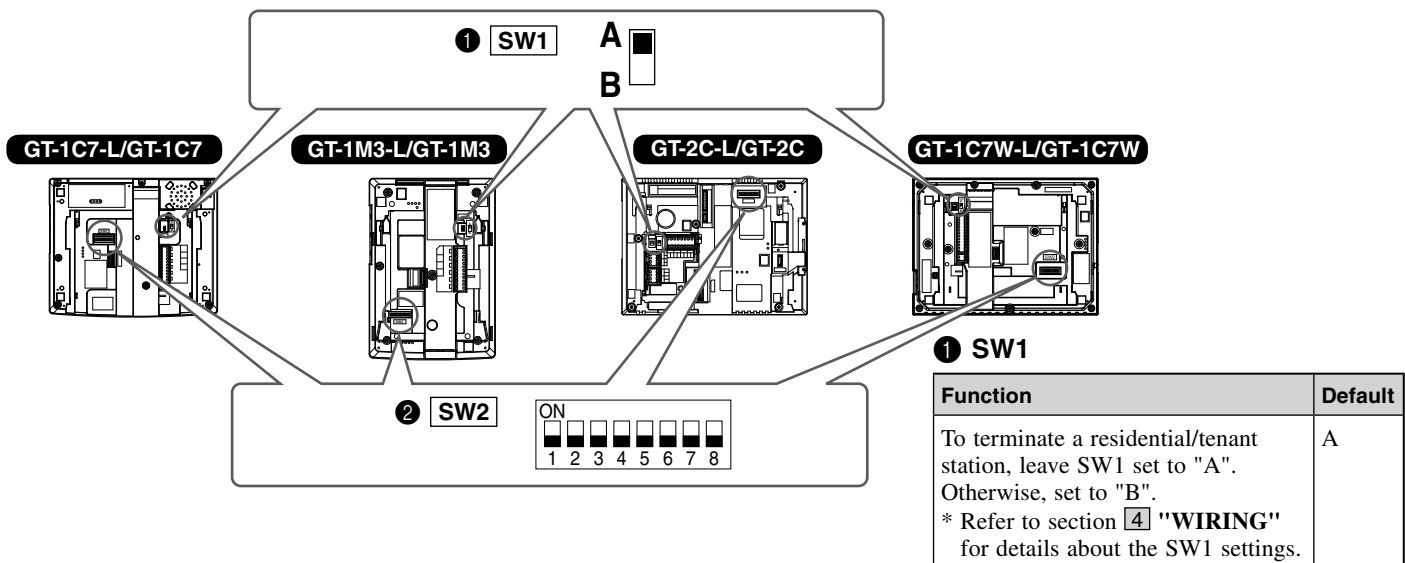

2 SW2

Residential/tenant stations must be linked to entrance/guard stations for enabling calling and communication.

All video residential/tenant stations can have "UNIT Link-ID" set by using SW2.

Function	Default
The DIP switches of SW2 must be used when setting UNIT Link-IDs by using the "Manual Setting" method. If using the "Automatic Setting" method, do not change the default setting "0000 0000".	1: OFF 2: OFF 3: OFF 4: OFF 5: OFF 6: OFF 7: OFF 8: OFF (0000 0000)
<ul style="list-style-type: none"> Automatic setting: Set the DIP switches to "0000 0000". The UNIT Link-ID is set automatically. * For GT-1D and GT-1A, UNIT Link-ID is always set automatically. Manual setting: Set the UNIT Link-ID by using the DIP switches. Decide the UNIT Link-IDs in advance, and coordinate with the system installer for SW2 DIP switch settings. 	
NOTE: If there is mixture of video and audio residential/tenant stations in the site, only Automatic setting should be used.	

How to set "UNIT Link-ID"

There are two methods for link setting.

By Hand-shaking	The entrance/guard stations must be put into programming mode and communication must be established one-by-one with each resident station. Either "Automatic setting" or "Manual setting" is available.
By GT Setup Tool	Every residential/tenant station must be set with a unique residence UNIT Link-ID, as shown below. Link establishment is performed with the GT setup tool. Only the "Manual setting" for UNIT Link-IDs is available. The DIP switches on SW2 must be set in advance.

Setting method

1 Change the decimal notation ID to binary to set the residence ID.

- 1 indicates (ON) and 0 indicates (OFF).
- For binary notation, refer to the DIP switch & ID list for residential/tenant stations^(*) in the setup tool and perform settings as shown below.

Decimal notation	Binary notation	DIP switches
1	0000 0001	<input type="checkbox"/> <input type="checkbox"/> <input type="checkbox"/> <input type="checkbox"/> <input type="checkbox"/> <input type="checkbox"/> <input type="checkbox"/> <input type="checkbox"/>
2	0000 0010	<input type="checkbox"/> <input type="checkbox"/> <input type="checkbox"/> <input type="checkbox"/> <input type="checkbox"/> <input type="checkbox"/> <input type="checkbox"/> <input type="checkbox"/>
3	0000 0011	<input type="checkbox"/> <input type="checkbox"/> <input type="checkbox"/> <input type="checkbox"/> <input type="checkbox"/> <input type="checkbox"/> <input type="checkbox"/> <input type="checkbox"/>
4	0000 0100	<input type="checkbox"/> <input type="checkbox"/> <input type="checkbox"/> <input type="checkbox"/> <input type="checkbox"/> <input type="checkbox"/> <input type="checkbox"/> <input type="checkbox"/>
⋮	⋮	⋮
48	0011 0000	<input type="checkbox"/> <input type="checkbox"/> <input type="checkbox"/> <input type="checkbox"/> <input type="checkbox"/> <input type="checkbox"/> <input type="checkbox"/> <input type="checkbox"/>
⋮	⋮	⋮
250	1111 1010	<input type="checkbox"/> <input type="checkbox"/> <input type="checkbox"/> <input type="checkbox"/> <input type="checkbox"/> <input type="checkbox"/> <input type="checkbox"/> <input type="checkbox"/>

2 • Create a correlation table with the setup tool between the ID set for residences/tenants and the residential/tenant station names and upload this to the entrance station or guard station.

- * For information on how to use the setup tool, see the **GT SYSTEM Setting Manual** and **Aiphone GT Setup Tool for Windows** on the Aiphone website. Saving programmed data and resident information data to your PC is recommended.
- In addition, set up the system for the entrance station(s), guard station(s), and residential/tenant stations. (Refer to the **GT SYSTEM Setting Manual**.)

(*1): The DIP switch & ID list for residential/tenant station is available from the Aiphone website.

Aiphone website: <http://www.aiphone.net/>

NOTE: Refer to the **GT SYSTEM Setting Manual** for configuring the system setup.

6 CHECK FOR INSTALLATION

When checking operation after system installation shows a malfunction in spite of no error in equipment terminal connections, check for the following "grounding point" and "ground fault" in wiring.

Tools required: Analog tester

NOTES:

- A digital tester cannot make a precise reading.
- A megohmmeter cannot be used.

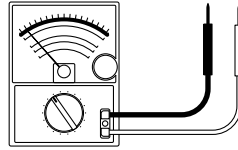

6-1 Finding a proper "grounding point" for power supply

- 1 Set the tester for 250V AC or more.
- 2 Find the "hot" side of the AC outlet to be connected with a power plug.
 - 2-1. Put one tester rod to the point that seems to be a grounding point.
 - 2-2. Touch the other tester rod contact to one of the AC outlet slots to find the side where the tester needle swings.
The side where the tester needle swings is the "hot" side.

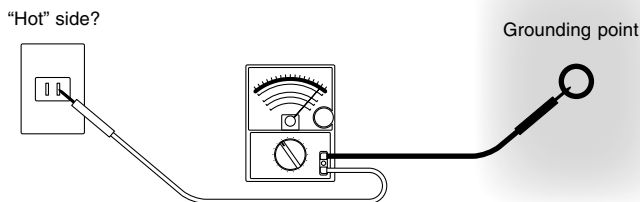

- 3 Find the proper grounding point.
 - 3-1. With one tester rod put on the "hot" side, put the other to the point that seems to be a grounding point.
* If the needle swings to the power supply value for your country, it will be considered a proper grounding point.
If the needle does not reach the power supply value, it will not be considered a proper point.
 - 3-2. Find the grounding point by repeating this step until the needle points to the proper value.

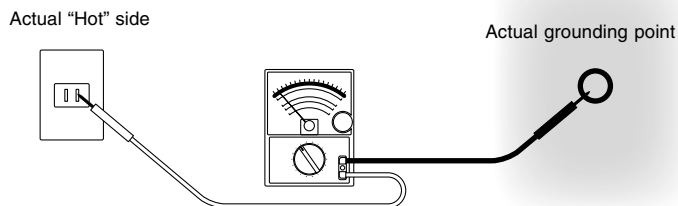

- 4 Connect the power supply ground terminal [⏏] with the grounding point found in step 3.

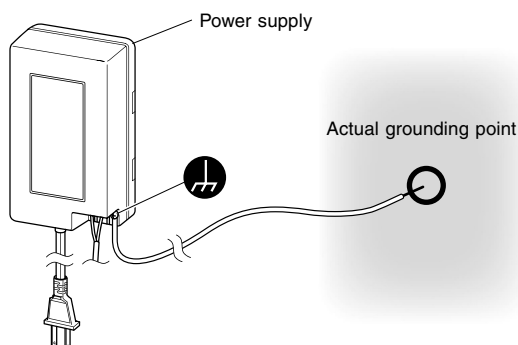

6-2 Checking "ground fault" with tester

What is "ground fault"?

"Ground fault" means the state where internal copper wire is touching a metal part (ground) in the building because the coating on the wiring of the intercom system is peeled off. This may cause the equipment to malfunction. Being in the ground fault state, the whole system will be damaged seriously by a "power surge."

Inspection conditions:

Important

- Check that the power supply is grounded properly as described in [6-1](#).
- Before starting inspection, make sure all control units (GT-BC, GT-VBC, GT-BCXB, GT-VBX), entrance station, and guard station are turned on. (Only when the equipment is installed)

Inspection procedure:

- 1 Set the tester for around 50V DC.
- 2 Put one tester rod to the power supply ground terminal [A]. If the power supply is not nearby, find a grounding point referring to [6-1](#).
- 3 With one tester rod put on the power supply ground terminal, put the other to the following terminals to be inspected.

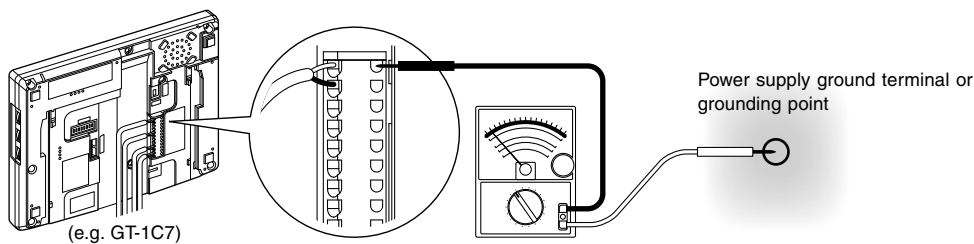

Product name	Terminal to be inspected
GT-BC	All [R1] and [R2]
GT-BCXB-N	All [R1] and [R2]
GT-VBC	All [A1], [A2], [B1] and [B2]
GT-VBX	All [A1], [A2], [B1] and [B2]
GT-MCX	[R1], [R2], [A1], [A2], [B1], [B2]
GT-VB	[A1], [A2]
GT-DB(-V, -VN)	[R1], [R2]
GT-DMB(-V, -LVN)	[R1], [R2], [A1], [A2]
GT-MKB-N	[R1], [R2], [A1], [A2], [B1], [B2]

Product name	Terminal to be inspected
GT-1C7W(-L) GT-2C(-L) GT-1C7(-L) GT-1M3(-L)	All [R1], [R2], [B1] and [B2]
GT-1A, GT-1D	All [R1] and [R2]
GT-4Z	All [R1], [R2], [B1] and [B2]
GT-1Z	All [B1] and [B2]
GTW-LC	[R1], [R2]
JO-DV	[A1], [A2]
DP (Distribution Point)	(Each line)

- 4 If the tester needle does not swing in step 3, it will be judged "no ground fault."

* If the tester needle swings, there is a ground fault in wiring between the power supply and the inspected point. (The same is true in the case where the needle swings reversely.)

Solution:

Divide the wiring into sections or trunk lines, identify the ground fault point, and remove the cause.

REGULATIONS

FCC

This device complies with part 15 of the FCC Rules. Operation is subject to the following two conditions: (1) This device may not cause harmful interference, and (2) this device must accept any interference received, including interference that may cause undesired operation.

NOTE: This equipment has been tested and found to comply with the limits for a Class B digital device, pursuant to part 15 of the FCC Rules. These limits are designed to provide reasonable protection against harmful interference in a residential installation. This equipment generates, uses and can radiate radio frequency energy and, if not installed and used in accordance with the instructions, may cause harmful interference to radio communications. However, there is no guarantee that interference will not occur in a particular installation. If this equipment does cause harmful interference to radio or television reception, which can be determined by turning the equipment off and on, the user is encouraged to try to correct the interference by one or more of the following measures:

- Reorient or relocate the receiving antenna.
- Increase the separation between the equipment and receiver.
- Connect the equipment into an outlet on a circuit different from that to which the receiver is connected.
- Consult the dealer or an experienced radio/TV technician for help.

Changes or modifications to this equipment not expressly approved by the party responsible for compliance could void the user's authority to operate the equipment. This device complies with Part 15 of the FCC rules. Operation is subject to the following two conditions: (1) this device may not cause harmful interference, and (2) this device must accept any interference received, including interference that may cause undesired operation. Privacy of communications may not be ensured when using this telephone. To ensure safety of users, the FCC has established criteria for the amount of radio frequency energy that can be safely absorbed by a user or bystander according to the intended usage of the product. This product has been tested and found to comply with the FCC criteria. To comply with FCC RF exposure requirements, the device must be installed and operated 20 cm (8 inches) or more between the product and all person's body. Keep a distance of more than 10 cm (3-15/16") from person's body while speaking. If you use the device within 10 cm (3-15/16"), please use within 1 minute.

INDUSTRY CANADA

CAN ICES-3 (B)/NMB-3(B)

WEEE

The object area of  is the EU.

WARRANTY

Aiphone warrants its products to be free from defects of material and workmanship under normal use and service for a period of 2 years after delivery to the ultimate user and will repair free of charge or replace at no charge, should it become defective upon which examination shall disclose to be defective and under warranty. Aiphone reserves unto itself the sole right to make the final decision whether there is a defect in materials and/or workmanship; and whether or not the product is within the warranty. This warranty shall not apply to any Aiphone product which has been subject to misuse, neglect, accident, power surge, or to use in violation of instructions furnished, nor extended to units which have been repaired or altered outside of the factory. This warranty does not cover batteries or damage caused by batteries used in connection with the unit. This warranty covers bench repairs only, and any repairs must be made at the shop or place designated in writing by Aiphone. This warranty is limited to the standard specifications listed in the operation manual. This warranty does not cover any supplementary function of a third party product that is added by users or suppliers. Please note that any damage or other issues caused by failure of function or interconnection with Aiphone products is also not covered by this warranty. Aiphone will not be responsible for any costs incurred involving on site service calls. Aiphone will not provide compensation for any loss or damage incurred by the breakdown or malfunction of its products during use, or for any consequent inconvenience or losses that may result.

