

# DSP-10

## Vehicle Detector



---

# 1. Contents

---

Figures .....	3
<b>2. Introduction .....</b>	<b>4</b>
<b>3. Technical Data .....</b>	<b>5</b>
Functional Data.....	5
Electrical Data.....	5
Environmental Data.....	6
Mechanical Data .....	6
<b>4. Features and Functions.....</b>	<b>7</b>
Detector Reset.....	7
Presence Detection.....	7
Pulse Detection.....	7
Fail-Safe vs Fail-Secure .....	8
Sensitivity.....	8
Frequency (DIP Switches 9 and 10) .....	8
Fail Memory (DIP Switch 8) .....	9
Extended Presence (DIP Switch 7).....	9
Output B Selection (DIP Switches 5 and 6).....	9
Sensitivity Boost (DIP Switch 4).....	11
Extension (DIP Switches 2 and 3) .....	12
Delay (DIP Switch 1).....	12
Indicators.....	12
<b>5. Installation .....</b>	<b>16</b>
General Rules and Best Practices for Inductive Loops .....	16
Detector Installation.....	17
Loop Installation .....	18
<b>6. Configuration .....</b>	<b>22</b>
Wiring .....	22
Internal Settings .....	22
<b>7. Troubleshooting .....</b>	<b>23</b>
No Power LED .....	23
Power LED Flashes On Once Every 2 Seconds.....	23
Power LED Flashes Slowly (1 Hz) .....	23
Power LED Flashes Quickly (5 Hz).....	24
Power LED Shows Two Quick Flashes Once Every Two Seconds.....	24
Detect LED Intermittently Comes On / Stays On Without a Vehicle Present.....	25
Detect LED Will Not Come On With a Vehicle Present.....	26

## Figures

---

Figure 1: Product Views.....	4
Figure 2: Physical Dimensions .....	6
Figure 3: Outputs with No Delay or Extension .....	10
Figure 4: Outputs with Delay.....	10
Figure 5: Outputs with Extension .....	11
Figure 6: Outputs with Delay and Extension .....	11
Figure 7: Power LED States.....	14
Figure 8: Detect LED States .....	15
Figure 9: Loop Installation .....	20
Figure 10: Saw Cut for Home Run Exit and Chiseled Corner for Home Run Exit.....	20
Figure 11: Fail-Safe and Fail-Secure Internal Jumpers .....	22

---

## 2. Introduction

---

The DSP-10 Detector is intended to be a top of the line single channel detector. Many features have been included which are normally found only on more expensive models. The small package is powered by a high-performance 16-bit microcontroller that does not skimp on performance. The DSP-10 Detector was designed to retrofit into existing locations that may require a detector upgrade. This allows maintenance personnel to carry only one detector to meet most, if not all, of their vehicle detection needs.

The detector uses an 11-pin relay socket for connections.

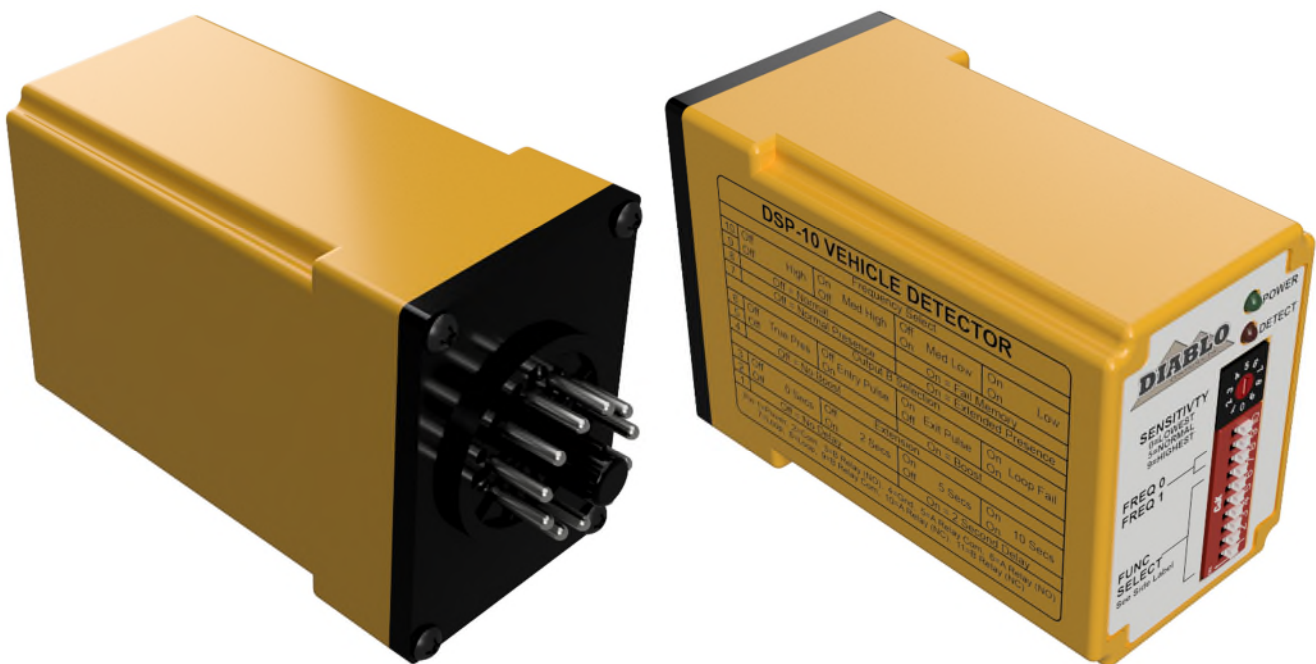

Figure 1: Product Views

---

## 3. Technical Data

---

### Functional Data

---

Sensitivity: Ten sensitivities are user selectable.

Setting	Sensitivity	Setting	Sensitivity
0	.48% $\Delta$ L/L	5	.08% $\Delta$ L/L
1	.32% $\Delta$ L/L	6	.06% $\Delta$ L/L
2	.24% $\Delta$ L/L	7	.04% $\Delta$ L/L
3	.16% $\Delta$ L/L	8	.03% $\Delta$ L/L
4	.12% $\Delta$ L/L	9	.02% $\Delta$ L/L

Frequency Settings: There are four frequency settings available. The actual loop frequency is dependent on loop circuit inductance.

DIP Switch		Frequency
9	10	
OFF	OFF	High
OFF	ON	Medium High
ON	OFF	Medium Low
ON	ON	Low

B Pulse Output: 250ms  $\pm$ 15ms.

Response Time: Response time is dependent on the sensitivity selected.

Setting	Response Time	Setting	Response Time
0	70ms $\pm$ 10ms	5	70ms $\pm$ 10ms
1	70ms $\pm$ 10ms	6	140ms $\pm$ 20ms
2	70ms $\pm$ 10ms	7	140ms $\pm$ 20ms
3	70ms $\pm$ 10ms	8	140ms $\pm$ 20ms
4	70ms $\pm$ 10ms	9	140ms $\pm$ 20ms

Vehicle Hold Time: In Normal Presence Mode: Approximately 1 hour for a detection of 1%  $\Delta$ L/L.  
In Extended Presence Mode: Approximately 19 hours for a detection of 1%  $\Delta$ L/L.

### Electrical Data

---

Loop Inductance: 20 microhenries to 1500 microhenries (including lead-in inductance). Not all frequency settings are available at inductances below 30 microhenries.

Operating Voltages: Three power versions:  
10.5 volts to 30 volts AC or DC with over voltage protection  
100 volts to 135 volts AC  
200 volts to 270 volts AC

Output Relay Rating: 3 amps @ 125 volts

Current Draw:	10.5 volts to 30 volts AC or DC	75 milliamps maximum.
	100 volts to 135 volts AC	7.5 milliamps maximum.
	200 volts to 270 volts AC	3.75 milliamps maximum.

## Environmental Data

---

Operating Temperature: -35°F to 165°F (-37°C to 74°C)

Storage Temperature: -40°F to 176°F (-40°C to 80°C)

Humidity: Up to 95% relative humidity non-condensing

## Mechanical Data

---

Mounting Position: Any

Housing Material: Lexan

Housing Size: 2.36 inches (High) x 1.75 inches (Wide) x 4.06 inches (Deep)  
 59.94 mm (High) x 44.45 mm (Wide) x 103.12 mm (Deep)

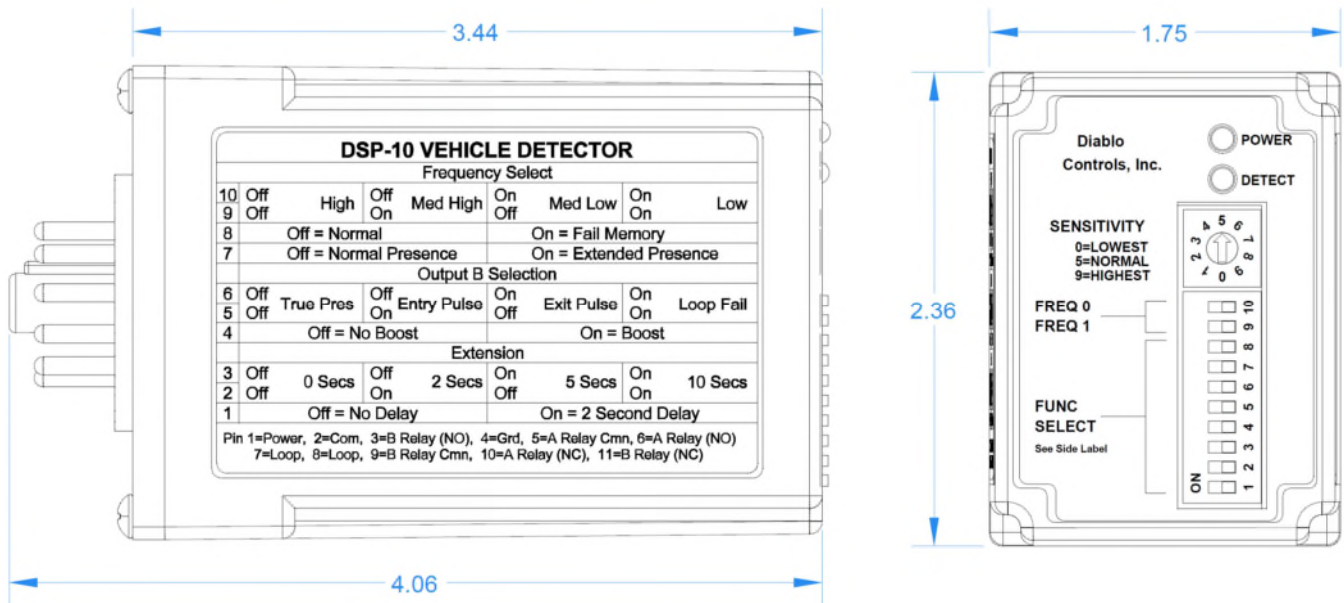

Figure 2: Physical Dimensions

---

## 4. Features and Functions

---

### Detector Reset

---

When any of the 10-position DIP switches or the 10-position rotary switch is changed, the detector will perform a detector wide reset. Both LEDs will turn off for 500 milliseconds at the start of the reset event, then on for 500 milliseconds, and then it will indicate if the internal setting is for Fail-Safe or Fail-Secure configuration of the detector. For Fail-Safe the LEDs will be on for another 500 milliseconds then off for 500 milliseconds before returning to their normal states. For Fail-Secure the LEDs will flash at 50 milliseconds on and 50 milliseconds off rate for another 1000 milliseconds before returning to their normal states. The detector will not output any detections during this two second reset period. If a prior loop fault is being displayed it will be cleared. If a vehicle is over the loop during the reset period it will not be detected.

### Presence Detection

---

The A output will always operate in the presence detection mode. The Delay and Extend features may modify the output behavior. Once activated, the output will remain activated as long as a vehicle is detected over the loop. After four minutes of continuous detection, the detector will begin to slowly retune the detector with the goal of tuning out the vehicle that stalled or parked on the loop over a relatively long time. The retuning process takes about an hour to complete in the Normal Presence mode and about 19 hours in the Extended Presence mode with a vehicle detection of 1%  $\Delta L/L$ . When the retuning process is complete, any loop area that vehicles can still travel over will still detect the vehicle as expected. Once the vehicle leaves, the detector will recover from the retuning process within 1 second.

The B output can be set to operate in the True Presence mode. In this mode the B output activates as soon as a vehicle enters the loop and drops as soon as the loop is no longer occupied. The output will ignore any Delay or Extend features that are currently active.

### Pulse Detection

---

The B output can be configured for Pulse on Entry or Pulse on Exit operation. The pulse generated by the output will be 250 milliseconds long. The B output will follow any Delay or Extend features that are currently active. Pulse operation is not available on the A output.

In Pulse on Entry mode, the B output will pulse when the A output activates. If the delay feature is enabled, the pulse will not occur until the delay has timed out and the loop is still occupied. The output will not pulse again until the loop has been unoccupied and any enabled extension has timed out.

In Pulse on Exit mode, the B output will pulse when the A output deactivates. If one of the extension features is enabled, the pulse will not occur until the extension has timed out and the loop is still vacant. The output will not pulse again until the loop has been reoccupied and any enabled delay has timed out.

## Fail-Safe vs Fail-Secure

---

Here's a little note on fail-safe versus fail-secure operation. On the DSP-10, the option for fail-safe or fail-secure only applies to the A output. In general, a fail-safe detector will activate the output when the loop circuit is failed. This is useful on a safety loop to prevent accidental closure of a gate arm on a vehicle. On the free exit loop this will keep the gate open until the situation is fixed. Fail-safe is used in applications where it is important to allow traffic flow to continue. A fail-secure detector will not activate the output when the loop circuit is failed. This will keep the gate closed. This is useful in high-security areas or installations where containment is needed.

The B output is always fail-secure when not in the fail output mode.

The DSP-10 is one of the few vehicle detectors that honors fail-safe and fail-secure even in the absence of power. Inside the unit, on the main PC board, are three jumpers that set the failure mode. When placed in the fail-safe position, the A output relay will be fail-safe in the absence of adequate voltage. If placed in the fail-secure position, the reverse is true. The jumpers are factory set to be fail-safe. All three jumpers must be set to the same setting. Not doing this will cause incorrect operation of the A output.

## Sensitivity

---

The detector has ten user selectable sensitivity levels. In most situations the medium sensitivity 5 setting will work effectively. For those situations where setting 5 is not sensitive enough, raise the sensitivity one level at a time until the desired performance is obtained. For those situations where the detector is oversensitive, lower the sensitivity one level at a time until the desired performance is obtained. The sensitivity is factory set to 5.

Like most inductive loop vehicle detectors, the DSP-10 directly measures the change in frequency of the loop and from there, calculates the change in inductance when a vehicle interacts with it. The change in inductance is measured as  $\% \Delta L/L$  (reads as "percent delta L over L").

For the ten sensitivities, the thresholds are:

Setting	Sensitivity	Setting	Sensitivity
0	.48% $\Delta L/L$	5	.08% $\Delta L/L$
1	.32% $\Delta L/L$	6	.06% $\Delta L/L$
2	.24% $\Delta L/L$	7	.04% $\Delta L/L$
3	.16% $\Delta L/L$	8	.03% $\Delta L/L$
4	.12% $\Delta L/L$	9	.02% $\Delta L/L$

## Frequency (DIP Switches 9 and 10)

---

Another important variable is loop frequency. When loops are installed sufficiently far apart, any two loops will not interfere with each other. However, if two loops are fairly close together, say two to four feet apart, the inductive fields may couple together and may interact causing intermittent false detections. The two main variables for inductive coupling are distance and frequency separation. To aid in avoiding inductive coupling, each DSP-10 unit comes with two frequency switches. They are binary coded allowing up to four different

frequencies to operate within. If there are suspicions that one of the two loops are interacting, simply change one of the two unit's frequency settings.

DIP Switch		Frequency
9	10	
OFF	OFF	High
OFF	ON	Medium High
ON	OFF	Medium Low
ON	ON	Low

### Fail Memory (DIP Switch 8)

---

Normal operation is that during a loop failure, the green Power LED will indicate what type of loop failure (open, short, or large  $\Delta L/L$ ). During the loop failure the red Detect LED and output A will be active for fail-safe operation or inactive for fail-secure operation. If the loop recovers from its failure, the red and green LEDs, along with its two relay outputs, will operate normally again. However, when Fail Memory is enabled, the green LED will continue to indicate a previous failure by blinking 1850 milliseconds on, 50 milliseconds off, 50 milliseconds on again, and then 50 milliseconds off. This blinking sequence will repeat until a reset or power cycle occurs. Note that the red LED and relay outputs will continue to work normally.

### Extended Presence (DIP Switch 7)

---

Under normal conditions, the DSP-10 will hold a vehicle presence for a reasonable amount of time. If a vehicle parks over the loop and the detector measures a 1%  $\Delta L/L$ , it will slowly tune that vehicle out over a period of about one hour. For those instances where a longer period is desired, extended presence will hold that same vehicle for about 19 or 20 hours. This is quite a long time, but it isn't infinite. The DSP-10 does not have infinite presence.

### Output B Selection (DIP Switches 5 and 6)

---

Output B can be programmed to operate in one of four different modes that are selected using DIP switches 5 and 6. The following table identifies these four modes:

DIP Switch		Output B Mode of Operation
5	6	
OFF	OFF	True Presence
OFF	ON	Pulse on Entry
ON	OFF	Pulse on Exit
ON	ON	Fail

**True Presence:** The B output will be energized whenever a vehicle is present over the loop detection area. The A output can be modified by the delay and/or extension timing settings. The B output will not use these timing settings. For example, if 2 seconds of delay is set, output B will energize as soon as the vehicle is detected, while output A will wait for two seconds of continuous presence prior to energizing.

**Pulse on Entry:** Every time the loop is occupied, a single 250 milliseconds pulse will be output on the B output.

**Pulse on Exit:** Every time the loop becomes vacant or a vehicle is tuned out, a single 250 milliseconds pulse will be output on the B output.

**Fail:** If the DSP-10 recognizes some type of loop failure, a continuous output on the B output will be given. The B output will remain activated until the failure is corrected.

The following figures show the effects of delay and extension on the A & B outputs. The numbers between edges are the number of seconds in that period.

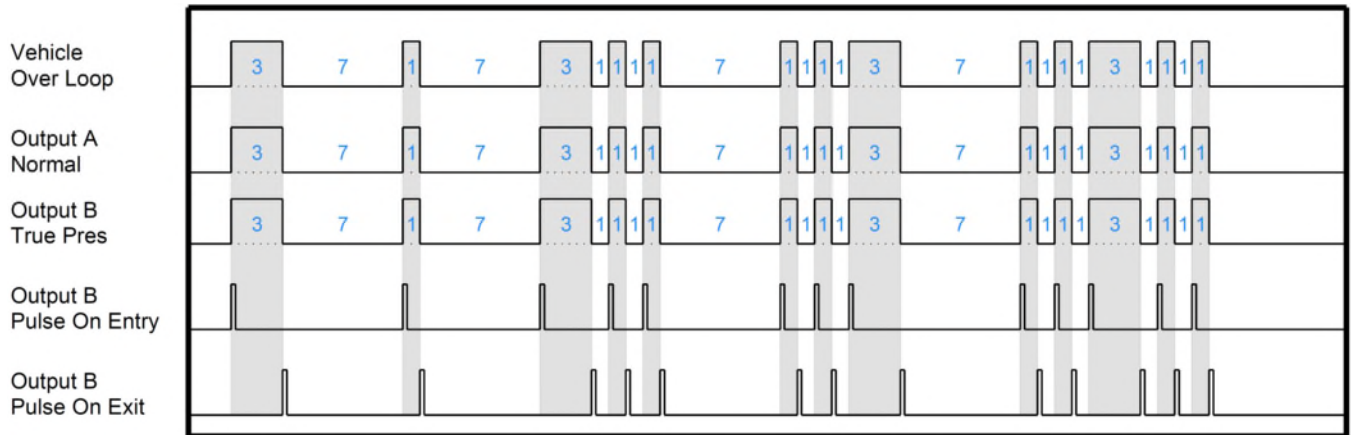

Figure 3: Outputs with No Delay or Extension

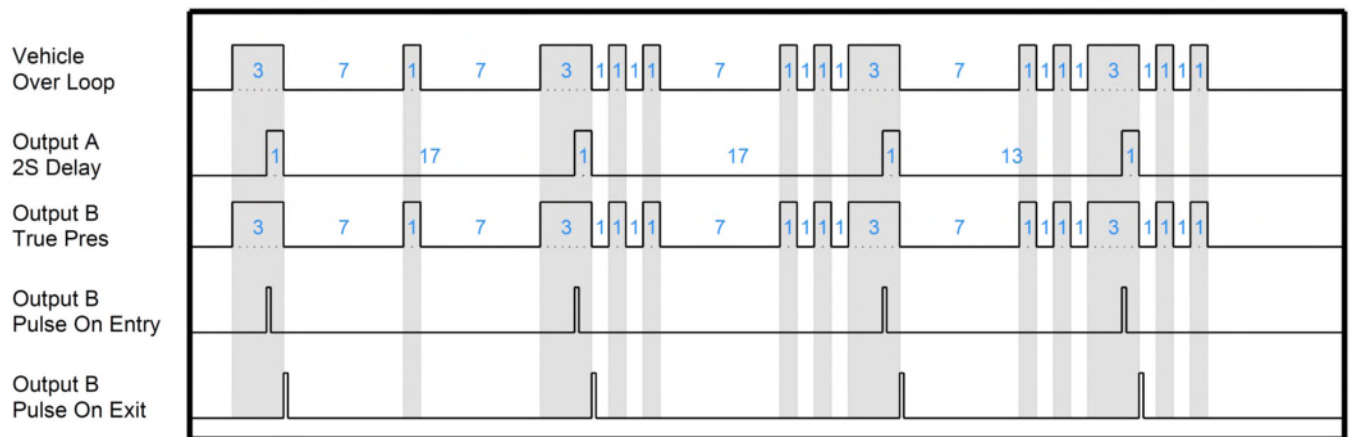

Figure 4: Outputs with Delay

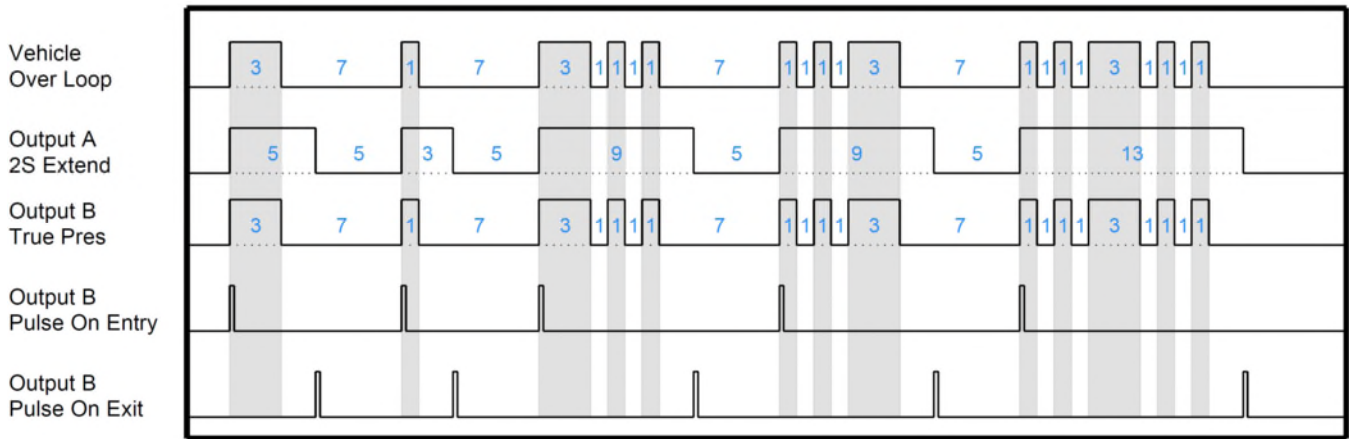

Figure 5: Outputs with Extension

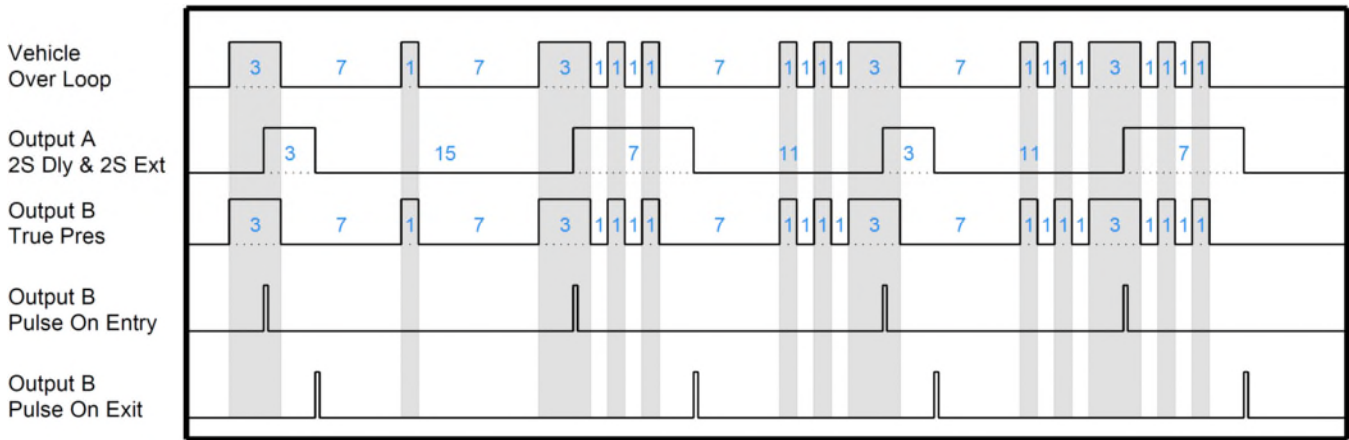

Figure 6: Outputs with Delay and Extension

## Sensitivity Boost (DIP Switch 4)

The detector has a user selectable feature that increases the sensitivity of a channel after initial detection. This feature is most often used to allow a detector to have a lower starting sensitivity and then increase it after a vehicle has been detected. This is useful in situations where high-bed tractor-trailer vehicles will be passing over the loop. With this feature the detector may be able to detect the high-bed portion of the vehicle without having to be overly sensitive and susceptible to false detections. NOTE: If detection of high-bed tractor-trailers is required, correctly sized loops must be used.

## Extension (DIP Switches 2 and 3)

---

Extension is the time added after a vehicle leaves the detection area. During this interval, the A output will remain activated, with the intent of allowing the vehicle to fully exit the detection area before the gate begins to close. If another vehicle arrives during this extension interval, the remainder of the extension time is canceled and the detector returns to the normal presence state. This interval is indicated by the red Detect LED blinking fast at 50 milliseconds on followed by 50 milliseconds off repeated until the interval is complete. There are four intervals to choose from: No extension, 2 seconds of extension, 5 seconds of extension, and 10 seconds of extension. The choices are summarized in the table below.

DIP Switch		Output A Extension Time
2	3	
OFF	OFF	0 seconds
ON	OFF	2 seconds
OFF	ON	5 seconds
ON	ON	10 seconds

## Delay (DIP Switch 1)

---

Delay is the time added after a vehicle arrives in the detection area but before the A output is activated. During the delay interval the A output relay will remain de-activated, requiring that the vehicle stay in the detection area for a full 2 seconds before activating the A output. This is useful at sites where vehicles traveling perpendicular to the gate may travel across the detection zone. This interval is indicated by the red Detect LED blinking slowly at 200 milliseconds on followed by 200 milliseconds off repeatedly until the interval is complete. The delay interval is fixed at 2 seconds.

## Indicators

---

The DSP-10 is equipped with two LED indicators: Power (Green) and Detect (Red).

**Power LED** – The green power LED indicates these possible states:

- |                             |   |
|-----------------------------|---|
| <b>Off</b>                  | The voltage applied to the detector is less than the minimum display voltage of approximately 7.75 volts. The LED will be off.  |
| <b>Low Voltage</b>          | The voltage applied to the detector is less than the minimum voltage for proper operation of approximately 10.25 volts. The LED will blink on for 50 milliseconds once every 2 seconds.   |
| <b>Reset in Fail-safe</b>   | At the start of a reset event (a DIP switch change, sensitivity change, or power cycle) the LED will turn off for 500 milliseconds, on for 500 milliseconds, off for 500 milliseconds, off for 500 milliseconds, and then display its normal state. |
| <b>Reset in Fail-secure</b> | At the start of a reset event (a DIP switch change, sensitivity change, or power cycle) the LED will turn off for 500 milliseconds, on for 500  |

milliseconds, blink repeatedly with 50 milliseconds on followed by 50 milliseconds off for one second, and then display its normal state.

**Open Loop**

When the detector senses that the loop is open or the inductance is too high, the LED will turn on for 500 milliseconds then off for 500 milliseconds repeatedly, for the duration of the fault.

If the fault is corrected and the Fail Memory feature is enabled, the LED will display the Prior Fault indication.

**Shorted Loop**

When the detector senses that a loop is shorted or the inductance is too low, the LED will turn on for 100 milliseconds then off for 100 milliseconds repeatedly, for the duration of the fault.

If the fault is corrected and the Fail Memory feature is enabled, the LED will display the Prior Fault indication.

**Large Change Fault**

When the detector senses that a loop is experiencing a large inductance change (greater than 30%), the LED will turn off for 100 milliseconds then on for 100 milliseconds for 500 milliseconds then stay on for 500 milliseconds and repeat the sequence for the duration of the fault.

If the fault is corrected and the Fail Memory feature is enabled, the LED will display the Prior Fault indication.

**Prior Fault**

The detector is equipped with the ability to remember prior faults that have occurred since the last power interruption or reset (changing a DIP switch or the sensitivity). The LED will turn on for 1850 milliseconds, off for 50 milliseconds, on for 50 milliseconds, off for 50 milliseconds and then repeat the sequence until power is cycled or the detector reset.

**Normal**

The LED is always on when the detector is in its normal state of operation.

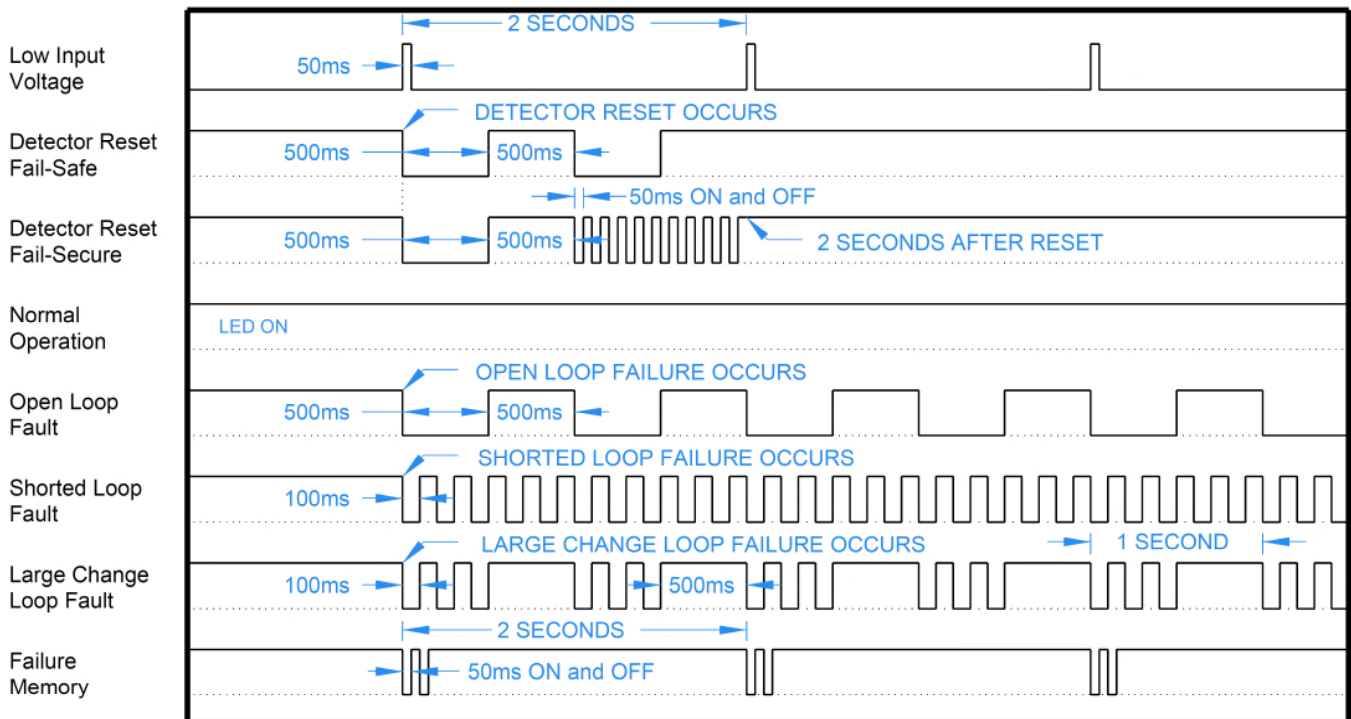

Figure 7: Power LED States

**Detect LED** – The red detect LED is used to display the status of the A output. There are several different statuses that can be displayed on this LED:

- Off** No vehicle present in the detection area.
- Reset in Fail-safe** At the start of a reset event (a DIP switch change, sensitivity change, or power cycle) the LED will turn off for 500 milliseconds, on for 500 milliseconds, off for 500 milliseconds, on for 500 milliseconds, and then finally display its normal state.
- Reset in Fail-secure** At the start of a reset event (a DIP switch change, sensitivity change, or power cycle) the LED will turn off for 500 milliseconds, on for 500 milliseconds, blink repeatedly with 50 milliseconds on followed by 50 milliseconds off for one second, and then display its normal state.
- Delay Interval** A vehicle has been detected but the A output is not activated due to the 2 second delay feature being active. The LED will turn on for 200 milliseconds and then off for two hundred milliseconds. If the vehicle leaves the detection area before the two second delay interval expires, the LED will return to the off state. If the vehicle is still present after 2 seconds, the LED will become solid and the A output will be activated.

### Extension Interval

A vehicle was detected but the detection zone is now empty and an extension interval is being timed. The extension interval can be programmed for no extension, 2 seconds, 5 seconds, or 10 seconds. When the detection area becomes vacant, the extension timer will start and the A output will continue to be activated. During this interval, the LED will blink quickly at 50 milliseconds on and 50 milliseconds off. If another vehicle enters the detection area during this interval, the extension time is cancelled and the LED will return to the solid state. Note: There is no delay interval for any newly arriving vehicle if a vehicle is already in the detection area or the detector is in the extension interval.

### Detect

The LED will be on solid when a vehicle is being detected and the delay interval (if activated) has finished timing.

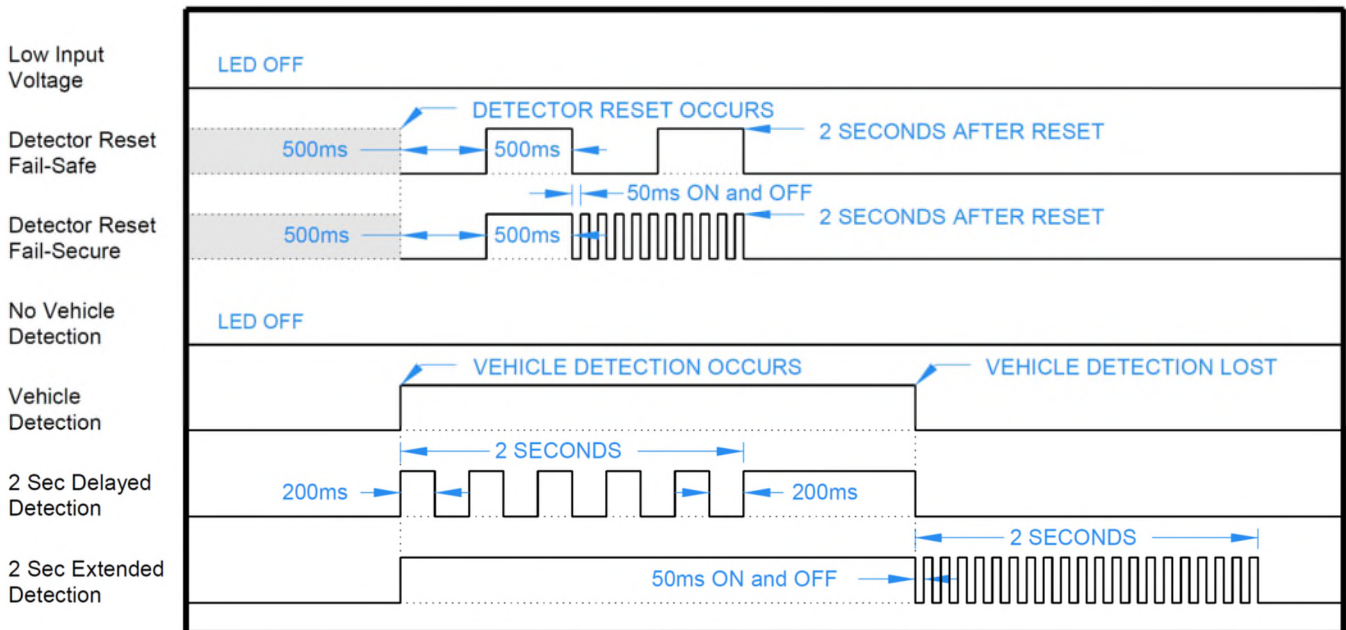

Figure 8: Detect LED States

---

## 5. Installation

---

### General Rules and Best Practices for Inductive Loops

---

Before beginning the installation, it is important to make that the loop you are about to use is appropriate for this installation. Here are some general rules and best practices that will help you ensure that the loop you use will have the desired performance and a long life.

1. The preferred insulation material for loop wire is cross-linked polyethylene (XHHN or XHHW are types of this wire). Wire with PVC insulation should never be used. This includes THHN. The cross-linked polyethylene is a much more durable insulation and, more importantly, has a much lower moisture absorption rate. Moisture absorption can affect loop stability.
2. Wire gauge of the loop wire has little to no impact on the sensitivity of the loop. A larger wire gauge may help extend the life of the loop, especially in asphalt installations where heavy truck traffic is expected.
3. Wire nuts should never be used in loop connections. At a minimum wire to wire connections should be crimped or use a screw terminal. Ideally, solder the connections.
4. Loop saw cuts should be mitered to reduce the loop wire bend angle to not exceed 45 degrees at any location.
5. Use backer rod to hold the loop wire at the bottom of the saw cut before sealing the loop. The backer rod should be cut into 1-inch pieces and one placed every foot or so, as needed.
6. If a loop installation will cross an expansion joint in the roadway surface some method of leaving some slack wire at the joint should be implemented. This can be done by core drilling a 1" or larger hole where the saw cut crosses the expansion joint and leaving a loop of wire in the hole each time you go through it when installing the loop wire. The other option is to dip the saw at the expansion joint to make the saw slot at least two inches deeper at the joint. Then when installing the loop wire, ensure that the wire lays all the way at the bottom of the saw slot at the expansion joint.
7. Useable detection height of a loop is 2/3rds of the shortest leg of the loop. Therefore, if you need to detect semi-truck trailers, no side of the loop can be shorter than 6'.
8. The approximate inductance of the loops can be calculated using the formula:

$$L = (P / 4) \times (N + N^2)$$

Where: L = Loop Inductance in microhenries ( $\mu\text{H}$ )

P = Perimeter of the loop in feet

N = Number of turns (wraps) in the loop

For example, a 6' by 14' loop with 2 turns would be:

$$L = (6 + 14 + 6 + 14) / 4 \times (2 + 2^2)$$

$$L = (40 / 4) \times (2 + 4)$$

$$L = 10 \times 6$$

Loop Inductance is approximately 60 $\mu\text{H}$ .

9. The approximate inductance of the lead-in cable can be calculated using a value of .22  $\mu\text{H}$  per foot for lead-in cable.

$100' \times .22 \mu\text{H} = 22 \mu\text{H}$  of inductance in 100' of lead-in cable.

10. The ratio of loop inductance to lead-in inductance should be 2 to 1 for a well-designed installation. Since the vehicle to be detected can only influence the loop inductance, letting the lead-in inductance get close to the loop inductance will effectively lower the sensitivity of the loop. This is usually only an issue when the loop is 50' or more away from the detector. If you do have a long lead-in, additional turns should be added to the loop until the 2 to 1 ratio is satisfied.
11. The ideal loop inductance is 50 to 500  $\mu\text{H}$ . Although the detector will tune to loops in the range of 20 to 1000  $\mu\text{H}$ , the 20 to 50 range should be avoided to provide a more stable loop and loss of sensitivity due to lead-in inductance. It is always better to have too much inductance than too little.
12. Lead-in wires must be twisted. Ideally, 3 to 6 twists per foot should be maintained. It is also important that the twists are tight. An air gap between the two wires should not exist as this can cause loop stability issues. The lead-in wires should be kept twisted until right before connection to the detector.
13. A figure 8 loop can be used in locations where electrical interference is expected or seen. This is a standard loop with an extra saw cut down the middle of the loop. This extra saw cut should point toward the source of the interference as much as practical. If the source is overhead or below ground (power lines) the saw cut should be parallel to the short side of the loop. The loop wire is placed in the saw cuts using a figure 8 motion. A figure 8 loop will have more inductance than a similar sized conventional loop.
14. If multiple loops are to be connected to the same detector there are several things to be aware of:
  - a. Always connect multiple loops in series. This increases the inductance and insures that a loop failure will cause a loop fault at the detector.
  - b. The loops connected together **must** be the same size and the same number of turns. Failure to do this will lead to the loops having different sensitivities that cannot be compensated for. This difference in sensitivity can very large.
  - c. Connecting two loops together will reduce the sensitivity of each loop by half.
  - d. If the two loops are within 6' of each other, the phasing of the loops should be considered. If the loops are on the same side of a gate and are being used to increase the size of the detection zone, the two edges closest to each other should have opposite phasing (North to South). This will increase the sensitivity in the area between the two loops. If the loops are on opposite sides of a gate, the loops should have the same phasing (North to North). This will decrease the sensitivity in the area between the two loops. Especially at the middle point between the two loops, it may be impossible to detect any object in this area. So, this phenomenon can be very useful in sliding gate and lift gate installations.

## Detector Installation

---

**Location:** The detector should be plugged in to the appropriate connector on the DoorKing operator.

**Mounting:** The detector will function when mounted in any orientation. Using the two holes in the detector, secure the detector in place.

**Wiring:** Attach the loops to the appropriate loop screw terminals. Wire nuts should never be used at any point in the loop circuit itself. All loop connections should be crimped or use screw terminals at a minimum and soldered for best long-term reliability. Special attention should be paid to ensure that the loop wires remain tightly twisted together. An air gap between the two wires for a loop may cause the detector to lock up if the wires are disturbed.

If connecting two loops to one channel of a detector, there are certain rules you should follow:

1. Always connect multiple loops in series, not parallel. A failure of one loop may not be identified if the loops are connected in parallel.
2. The loops should be the same size, shape, and have the same number of turns. If any of these items are different, the loops will have different sensitivities that cannot be adjusted for. The difference in sensitivity could be very significant.
3. Do not use a wire nut to connect the wire from each loop together. Wire nuts have a spring in them and will expand and contract with temperature. Even the slightest change in resistance can cause detector lock-ups.

## Loop Installation

---

The reliability and overall performance of the detector are greatly dependent on the loop itself. Several factors go into a good loop installation: type of wire used, loop configuration, and installation practices.

**Type of Wire Used:** The wire used for wiring the loop should have a jacket of cross-linked polyethylene or similar material that has very low moisture absorption properties. This would be a wire with an XLP jacket such as XHHW. THHN or similar wire types should never be used for loop wire.

The gauge of the wire to use depends on two factors: Distance in cable feet from the loop to the detector and stresses the wire may see. The gauge of the wire can be 20 AWG as long as the detector is within 50 feet of the loop in cable distance. For 50 to 100 feet, use at least 18 AWG wire. At greater than 100 feet, use a 16 AWG wire at a minimum. If the loop is installed in asphalt and there will be heavy vehicles or stopping and starting vehicles in the loop area, a 14 AWG or 12 AWG should be used to provide additional strength to the loop. This helps increase the life of the loop in areas where the asphalt may slowly move and/or deform due to wear and/or temperature.

**Loop Configuration:** The size and shape of the loop will determine what type of vehicles it can reliably detect. There are many variables that come into play including loop dimensions, percent of coverage, length of lead-in wire, number of turns in the loop area, and detection height to name just a few of them. One common rule is that the useable field height of a loop is  $\frac{2}{3}$  of the shortest leg of the loop. So, if you plan on using a 2.5' x 6' loop, the expected useable detection height would be 20" (The shortest leg is 2.5' or 30",  $30" \times 2 = 60"$ ,  $60" / 3 = 20"$ ). If the installation requires the detection of motorcycles as well as vehicles, the loop should go to within one foot of the curb or roadway edge, whichever is present. If only motor vehicle detection is required, within three feet of the curb or roadway edge is all that is required.

The number of turns to use in a loop is dependent on the size of the loop and length of the lead-in. Rather than dive into all of the calculations to arrive at a value, we will just give you a table of safe values based on the

number of square feet in the loop (length times width in feet). If you are unsure about your particular installation, call tech support for guidance.

Loop Size in Square Feet	Recommended Turns for <100' of Lead-in	Recommended Turns for 100' to 199' of Lead-in	Recommended Turns for 200' to 299' of Lead-in
5 to 6 square feet	7	8	10
7 to 9 square feet	6	7	9
10 to 15 square feet	5	6	8
16 to 23 square feet	4	5	6
24 to 54 square feet	3	4	5
55 to 150 square feet	2	3	3

**Installation Practices:** Permanent loops should be installed into the road surface by cutting slots into the road surface using a saw with an appropriate cutting disk for the road surface.

The slot cut should be wide enough that the wire being used will easily fit into the slot. This is needed so that the loop sealant used can fully encapsulate the wire. When the wire fits tightly in the slot, the sealant may not be able to get below the wire, leaving air pockets in the saw slot. If water finds its way in to these air pockets, over time, freeze thaw cycles can slowly jack the loop out of the saw slot causing loop failure.

The saw slot should be deep enough that the loop wire will have a minimum of ½” of sealant over the top wire in the slot. More is better. Going too deep with the saw cut is also a concern. Deep cuts in a road surface may impact the structural strength of the roadway, especially if any reinforcement material is cut. Using a smaller gauge of wire will allow for shallower saw cuts.

The corners of the loop should be crosscut at a 45° to help prevent damage to the wire insulation during installation and temperature cycling. The angled cuts should be at least 9” back from where the corner would be. The saw cuts should not go any further than necessary to ensure that the saw slots are at full depth where they meet.

Special consideration should be given to where the home run saw cut meets the loop saw cuts. Here either an additional saw cut should be made as shown in Detail A or the inside of the sharp corner should be removed with a chisel as shown in Detail B.

Once the saw slot has been cut, the slot should be cleaned of all loose material. High-pressure air should be directed in to the saw slot to remove all debris. This will also help remove dust from the saw cutting operation from the sides of the saw slot. This will allow better adhesion of the loop sealant to the saw slot.

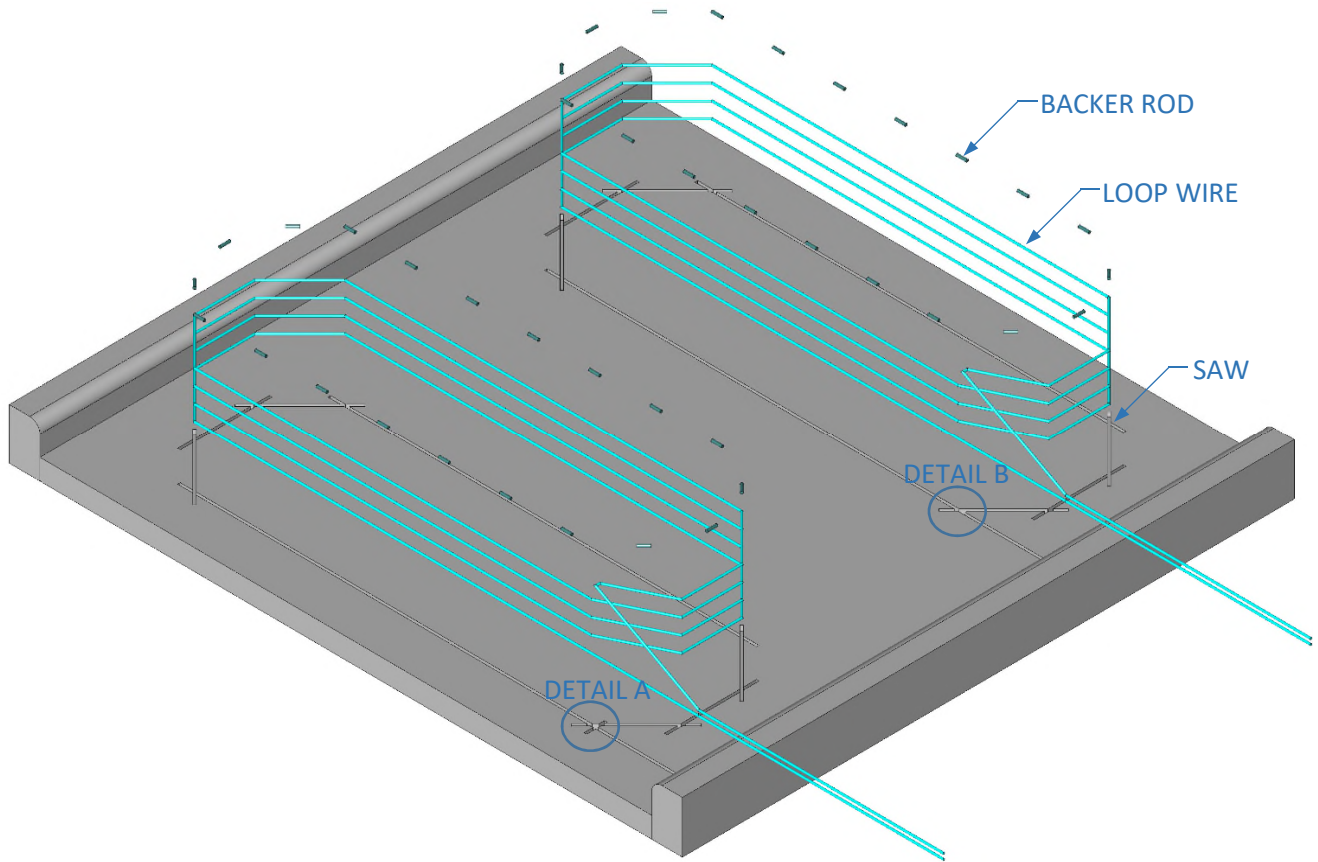

Figure 9: Loop Installation

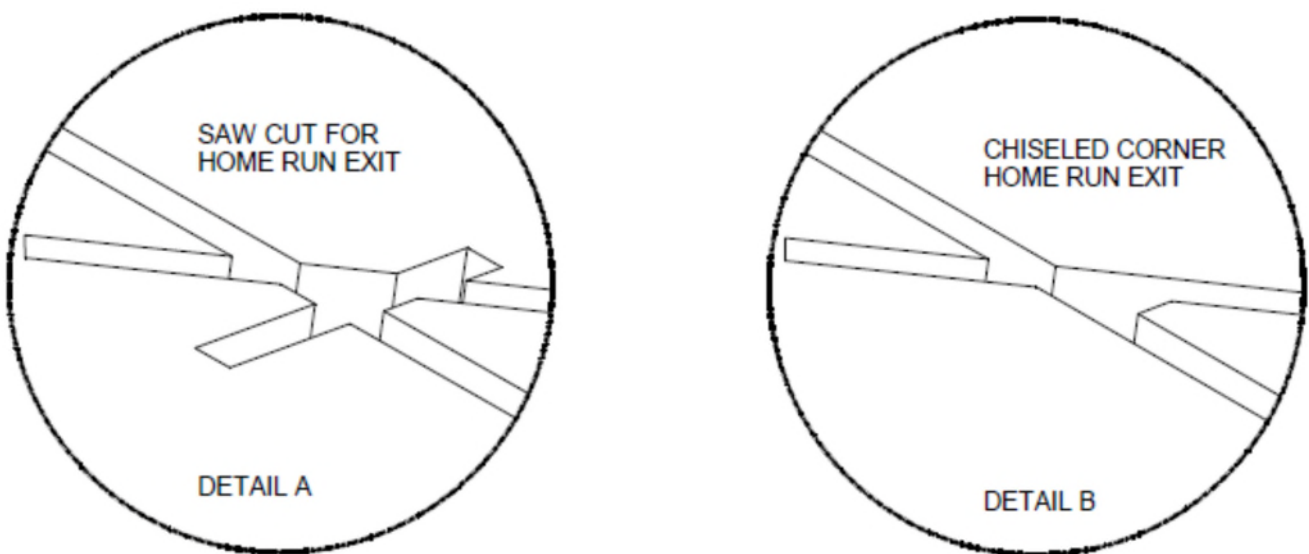

Figure 10: Saw Cut for Home Run Exit and Chiseled Corner for Home Run Exit

The loop wire should be installed as a continuous piece of wire from the detector to the loop, all of the turns in the loop, and back to the detector. Remember to make allowance for shrinkage in the wire length when the portion of the wire not in the roadway surface is twisted. The twisting is important for dealing with electrical noise. A splice of the loop wire should never be made in the roadway. If the loop wire needs to be spliced to another cable to get to the detector, the splice should be done in a junction box and the connections should be soldered and weatherproofed. Wire nuts should never be used at any point in the loop circuit.

In order to keep the loop wire at the bottom of the saw slot, 1" to 2" pieces of backer rod should be placed in the saw slot every 1 to 2 feet. The backer rod should be sized such that it fits snugly in the saw slot. Use a blunt object (not a screwdriver) to press the backer rod pieces down into the saw slot as far as they will go. Keeping the loop wire at the bottom of the saw slot allows the loop sealant to provide the maximum amount of protection possible from foreign object penetration. Never use a continuous piece of backer rod over the loop, as this would prevent the loop sealant from encapsulating the loop wire.

The loop sealant used should be appropriate for the roadway surface that was cut. Generally, epoxy or polyester based sealants are used for concrete surfaces and polyester or polyurethane based sealants are used for asphalt surfaces. However, these are not hard guidelines and specific circumstances will determine which type of sealant should be used.

Once the loop wire leaves the saw slot it should be twisted at least three times per foot. More is better. The twists should be kept tight to be most effective in reducing the effects of electrical interference.

---

## 6. Configuration

---

### Wiring

---

The wiring for each loop circuit must be kept twisted to provide the most reliable operation. Wire nuts should never be used for any connection in the loop circuit.

The last set of characters in the model number designate the operating voltage for the detector. There are three possible types:

- LV 10 to 30 volts, AC or DC (Low Voltage)
- 117 100 to 135 volts AC
- 230 200 to 270 volts AC

There is only one wiring configuration (pin-out) offered.

DSP-10-LV, DSP-10-117, and DSP-10-230:

Pin	Wire Color	Function
1	Black	DC + or AC Line hot
2	White	DC Common or AC Neutral
3	Orange	B ( N.O. closes for detect)
4	Green	Chassis Ground
5	Yellow	Relay A common
6	Blue	Relay A (N.O. closes for detect)
7	Gray	Loop
8	Brown	Loop
9	Red	Relay B common
10	Pink or White/Black	Relay A (N.C. opens for detect)
11	Violet or White/Red	Relay B (N.C. opens for detect)

### Internal Settings

---

There is only one setting internal to the detector and it is the fail-safe or fail-secure setting. There are three jumpers between the two relays. All three jumpers must be set the same way or unpredictable operation of the A output will occur. The printed circuit board is clearly marked with fail-safe on one side and fail-secure on the other. The detector is shipped from the factory in the fail-safe condition.

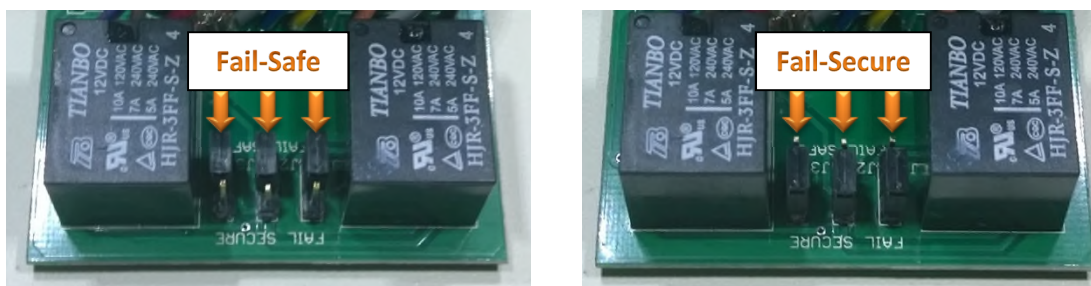

Figure 11: Fail-Safe and Fail-Secure Internal Jumpers

---

## 7. Troubleshooting

---

### No Power LED

---

The first step is to insure that the correct model of the detector is being used for the installation. Insure that the wiring is correct and the correct voltage is being used.

Use a meter to measure the voltage applied to the detector. For the LV version the voltage must be above 10.25V AC or DC. For the 117 version the voltage must be above 100V AC. For the 230 version the voltage must be above 200V AC.

If the correct voltage is applied and the power LED is not on, replace the detector.

### Power LED Flashes On Once Every 2 Seconds

---

The first step is to insure that the correct model of the detector is being used for the installation. Insure that the wiring is correct and the correct voltage is being used.

Use a meter to measure the voltage applied to the detector. For the LV version the voltage must be above 10.25V AC or DC. For the 117 version the voltage must be above 100V AC. For the 230 version the voltage must be above 200V AC.

If the correct voltage is applied and the power LED is still flashing, replace the detector.

### Power LED Flashes Slowly (1 Hz)

---

This flash rate indicates that the detector has an open loop, a high resistance in the loop circuit, or excessive inductance.

The first step is to confirm that the detector has a loop connected to it and the loop is connected to the correct pins (see the wiring configuration for the pin out).

If a loop is connected to the correct pins of the detector, disconnect the loop and using an ohmmeter, check the resistance of the loop circuit. If the resistance is above 5 ohms there is a bad connection or the wire has been damaged. The resistance will typically be 1.5 ohms or less.

If the resistance is below 5 ohms, the loop inductance should be checked. This is done using an inductance meter. The inductance of the loop should be less than 1500 microhenries. It is very unusual to have a loop with an inductance value this high, but it is possible with very large loops and many turns. If the loop inductance value is above 1500 microhenries, the loop will have to be replaced with a loop with less inductance. Contact technical support for help with very large loops.

If you do not have a meter capable of measuring resistance and inductance but do have another operating detector in the same box, you can skip to this step. Swap the loops between a working detector and a failing detector. If the problem follows the loop the loop is the problem. If it stays in the same detector, replace the detector.

## **Power LED Flashes Quickly (5 Hz)**

---

This flash rate indicates that the channel has a shorted loop, a low resistance across the loop circuit, or insufficient inductance.

The first step is to confirm that the loop is connected to the correct pins (see the wiring configuration for the pin out). If the wiring is correct, the next step is to confirm that the detector is working correctly. Disconnect the loop wires for the detector. The LED should begin flashing at a much slower rate (½ second on, ½ second off). If it does not change its flashing rate, change the detector.

If a loop is connected to the correct pins of the detector, disconnect the loop and using an ohmmeter, check the resistance of the loop circuit. If the resistance is below .2 ohms there is a short in the loop circuit. The resistance will typically be 0.5 ohms to 1.5 ohms.

If the resistance is above .2 ohms, the loop inductance should be checked. This is done using an inductance meter. The inductance of the loop should be more than 20 microhenries. If the loop inductance is less than 20 microhenries, the loop was probably not wound correctly and only has one turn in it. In this case the loop must be replaced. Other possibilities include a foreign object embedded in the saw cut and shorting some or all of the wires, or failed wire insulation due to the wire being exposed or the wrong type of wire being used. Very small loops may also have a low inductance value if sufficient turns were not added. Contact technical support for help with very small loops.

If you do not have a meter capable of measuring resistance and inductance but do have another operating detector in the same box, you can skip to this step. Swap the loops between a working detector and a failing detector. If the problem follows the loop the loop is the problem. If it stays in the same detector, replace the detector.

## **Power LED Shows Two Quick Flashes Once Every Two Seconds**

---

This flash rate indicates that the channel has had a failure of some type, but is currently working correctly.

Intermittent failures are usually open loop failures. Any splices in the loop wire should be redone. If there are any wire nuts used in the loop circuit, remove them and replace with a crimp connection or preferably, a soldered connection. The open loop fault could also be a fatigued point in the loop wire. This can occur at locations where the loop wires cross an expansion joint in the road surface. Any place where the loop wires must move, even if only a very tiny amount, can cause wire fatigue. The actual failure point may be very difficult to find. Often the loop must just be replaced if the issue persists but cannot be found.

It is possible for the intermittent failure to be a shorted loop fault. One possible source of this type of fault is a foreign object being embedded in the loop saw cut and damaging the wire. Another is that the loop wire has been damaged where it enters or exits a conduit or junction box, or that a conduit that the loop wire is in has been damaged (crushed, kinked, bent, cut, etc.).

## **Detect LED Intermittently Comes On / Stays On Without a Vehicle Present**

---

This type of symptom is usually caused by one of three issues: physical issues with the loop, electrical interference, moving objects in proximity to the loop.

**Physical Issues with the Loop** – There are many ways in which a loop installation can go bad. The insulation of the loop wire can fail. This can be due to the loop wire being exposed in the saw slot, damage to the wire insulation during loop installation, physical stressing of the wire due to movement (crossing of expansion joints or asphalt that has slowly moved or deformed), wires moving in the saw slot due to poor loop sealant encapsulation, foreign objects embedded in the saw slot, and poor electrical connections in the loop circuit.

The best way to check for any of these issues is to use a megohmmeter (commonly referred to as a megger). Disconnect the loop wires in question from the vehicle detector and any other electronic equipment. Connect one lead of the megger to one end of the loop wire and the other lead to earth ground. Measure the resistance. For accurate measurements the ground and the loop should be wet or at least damp (use a hose or a bucket of water if needed to get the area wet). The reading should be at least 100 megohms. If it is less than 50 megohms the insulation is compromised and the loop circuit has to be replaced. Between 50 and 100 megohms, the loop may or may not work properly and reliably.

**Electrical Interference** – There are several possible sources of electrical interference: loop cross-talk, power lines, electric motors, and insufficient twisting of the loop wires, just to name a few.

Other loops in the area that are connected to a different detector are prone to cross-talk (when the magnetic fields from different loops interfere with each other). Adjusting the loop frequency of one or both of the loops in the same area will usually allow you to find a setting that both loops will work reliably with.

Anything that uses electricity is a possible source for electrical interference depending on its proximity to the loop and the amount of energy being used. If you believe the loop is experiencing electrical interference, turn off the device believed to be the source of the interference and see if the problem goes away. Sometimes this is not possible and more technical means are needed to help identify the source. Call Technical Support in this case.

If the electrical interference is occurring in the wire from the loop to the detector, additional twisting should help mitigate the issue.

**Moving Objects in Proximity to the Loop** – Objects that can move and are metallic or somehow electrically conductive, may cause detection issues.

A common issue is movement of a slide gate or gate arm in close proximity to a loop. The best solution would be to move the detection area further away from the moving gate. We recommend that all loops should be at least 4 feet from a slide gate. Try lowering the sensitivity one level so that the desired vehicles are still detected, but not the moving gate. NOTE: Do not lower the sensitivity too much or vehicles will no longer be detected.

Another possibility is metal objects in close proximity to the loop. Utility manhole covers are objects that may move slightly when vehicle tires drive over them, especially if the vehicle turns while a tire is on the cover. Most

manhole covers can be bolted in place. Contact the owner of the manhole to see what can be done to mitigate the cover movement.

## **Detect LED Will Not Come On With a Vehicle Present**

---

The first thing to do is verify that the LED in question is still working. This is accomplished by a quick lamp test. Reset the detector by temporarily changing DIP switch 1. Both LEDs should turn off and turn on. If the Detect LED does not illuminate, replace the detector.

If the red LED illuminates, then perhaps the sensitivity setting is too low. There are many variables in determining overall sensitivity: loop size, number of turns, loop lead-in, percent coverage, etc. In most cases, a sensitivity setting of 5 is the correct setting. However, to compensate for some unusual loop geometries, this setting may be inadequate. Adjust the sensitivity one level higher and recheck the detector for proper detection.

If the channel sensitivity is set to 9 and the red LED still does not come on and you have another operating detector in the same box, swap the loops between a working detector and a failing detector. If the problem follows the loop the loop is the problem. If it stays in the same detector, replace the detector.